



This is a digital copy of a book that was preserved for generations on library shelves before it was carefully scanned by Google as part of a project to make the world's books discoverable online.

It has survived long enough for the copyright to expire and the book to enter the public domain. A public domain book is one that was never subject to copyright or whose legal copyright term has expired. Whether a book is in the public domain may vary country to country. Public domain books are our gateways to the past, representing a wealth of history, culture and knowledge that's often difficult to discover.

Marks, notations and other marginalia present in the original volume will appear in this file - a reminder of this book's long journey from the publisher to a library and finally to you.

### **Usage guidelines**

Google is proud to partner with libraries to digitize public domain materials and make them widely accessible. Public domain books belong to the public and we are merely their custodians. Nevertheless, this work is expensive, so in order to keep providing this resource, we have taken steps to prevent abuse by commercial parties, including placing technical restrictions on automated querying.

We also ask that you:

- + *Make non-commercial use of the files* We designed Google Book Search for use by individuals, and we request that you use these files for personal, non-commercial purposes.
- + *Refrain from automated querying* Do not send automated queries of any sort to Google's system: If you are conducting research on machine translation, optical character recognition or other areas where access to a large amount of text is helpful, please contact us. We encourage the use of public domain materials for these purposes and may be able to help.
- + *Maintain attribution* The Google "watermark" you see on each file is essential for informing people about this project and helping them find additional materials through Google Book Search. Please do not remove it.
- + *Keep it legal* Whatever your use, remember that you are responsible for ensuring that what you are doing is legal. Do not assume that just because we believe a book is in the public domain for users in the United States, that the work is also in the public domain for users in other countries. Whether a book is still in copyright varies from country to country, and we can't offer guidance on whether any specific use of any specific book is allowed. Please do not assume that a book's appearance in Google Book Search means it can be used in any manner anywhere in the world. Copyright infringement liability can be quite severe.

### **About Google Book Search**

Google's mission is to organize the world's information and to make it universally accessible and useful. Google Book Search helps readers discover the world's books while helping authors and publishers reach new audiences. You can search through the full text of this book on the web at <http://books.google.com/>



Math. 4767.22



SCIENCE CENTER LIBRARY

FROM

*The Institution*

.....  
.....



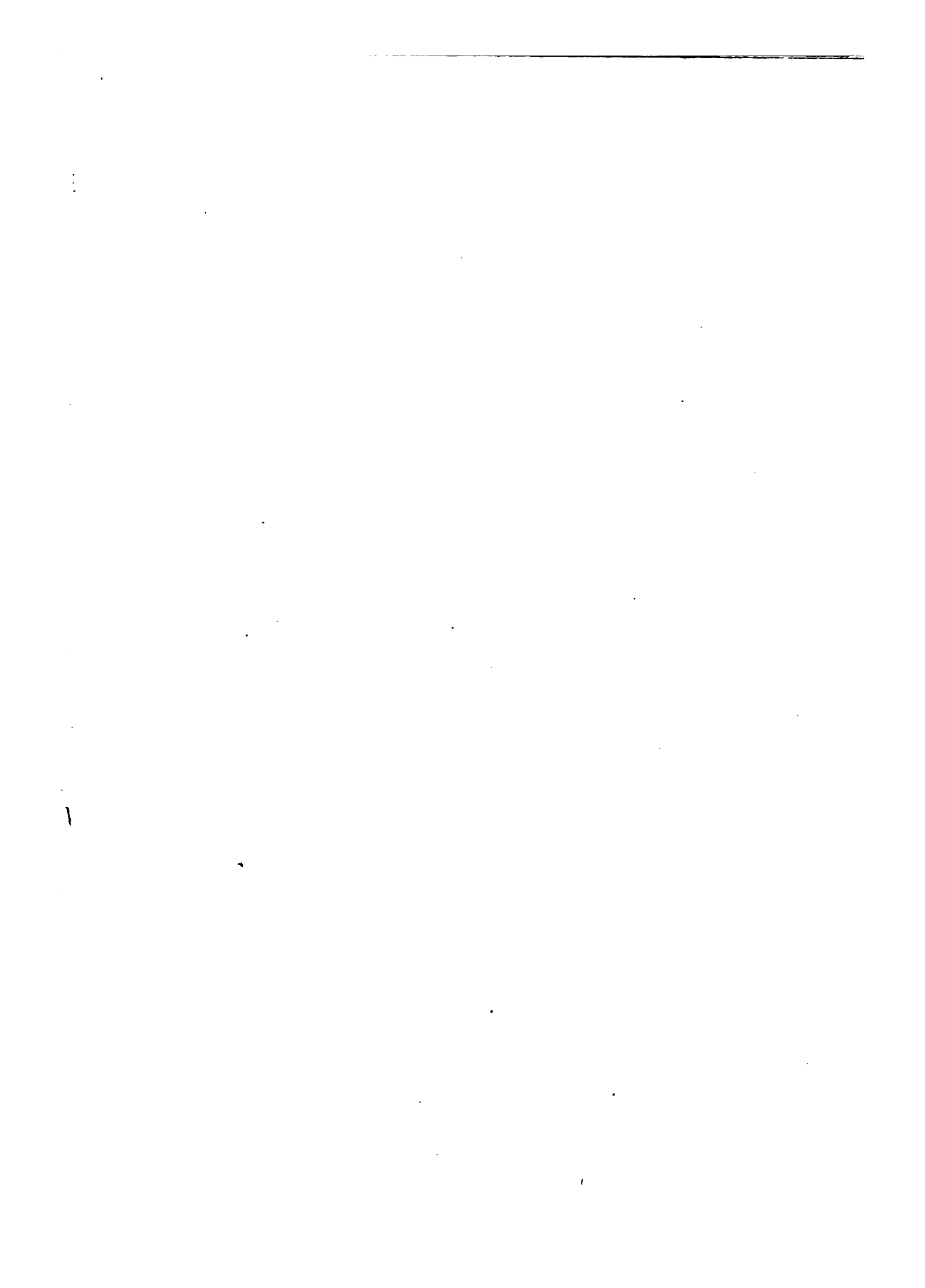

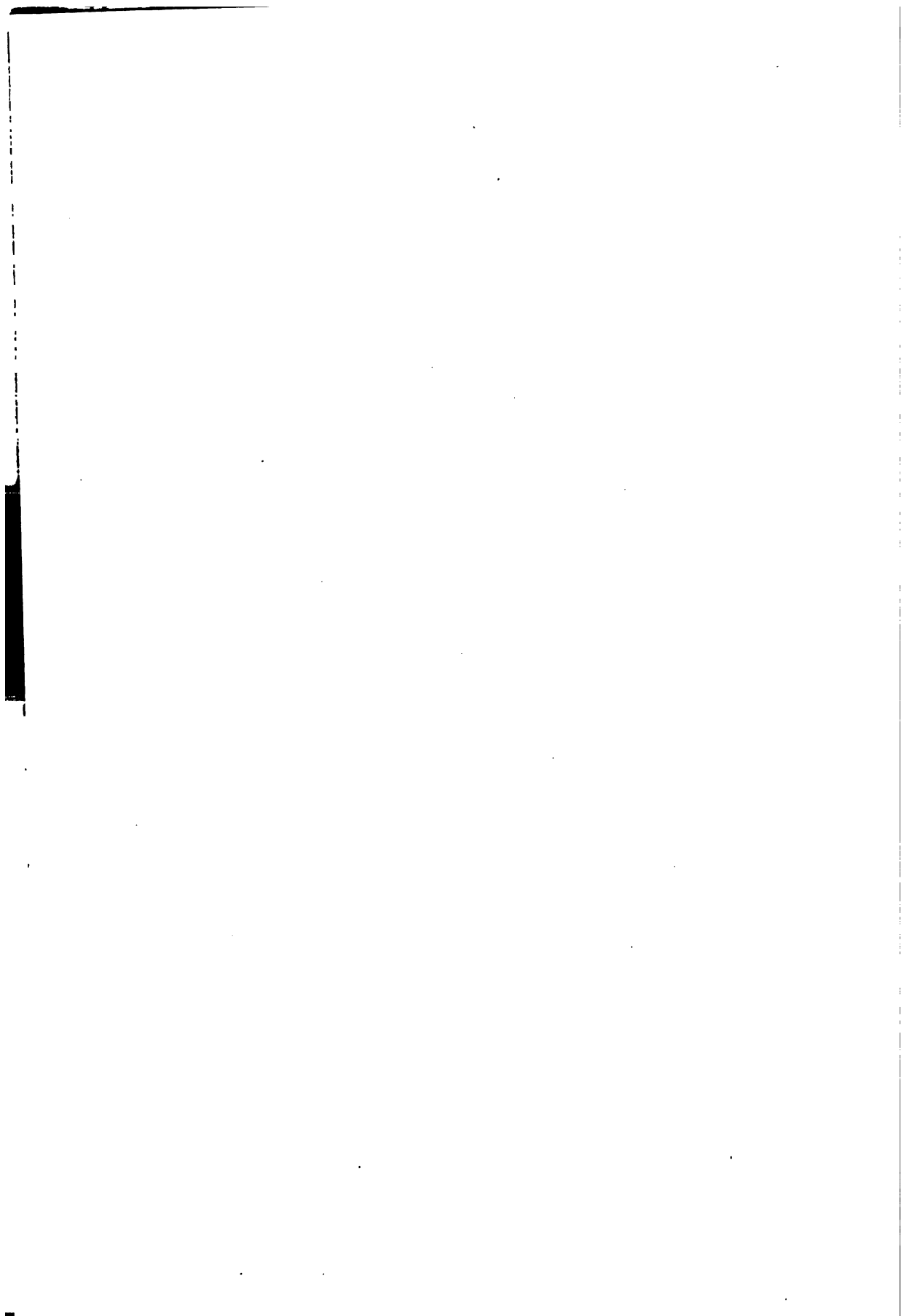

THE ANALYTICAL EXPRESSION OF THE RESULTS  
OF THE THEORY OF SPACE-GROUPS

△

Math 479.22  
1

---

BY  
RALPH W. G. WYCKOFF



PUBLISHED BY THE CARNEGIE INSTITUTION OF WASHINGTON  
WASHINGTON, OCTOBER, 1922

Math- 4709.22

✓



*The Institution*

**CARNEGIE INSTITUTION OF WASHINGTON**  
**PUBLICATION No. 318**

**THE TECHNICAL PRESS**  
**WASHINGTON, D. C.**

## PREFACE.

With the development of such methods of studying the arrangement of the atoms in crystals as are furnished by the phenomena of the diffraction of X-rays, the geometrical theory of space groups becomes of the utmost importance. Until recently the work published upon this theory has been directed primarily toward the preparation of a statement of all the different kinds of symmetry (groupings of elements of symmetry) which are crystallographically possible.

This statement, to be complete, must necessarily give all of the possible ways of arranging points in space which, by their arrangement, will express crystallographic symmetry. In its most general form such an analytical expression of the results of this theory was given by Schoenflies.\* Before it is applicable to the study of the structures of crystals, however, modifications in this original representation are necessary. First, there must be selected such a portion of the grouping that in its calculated effects upon X-rays it can be taken as typical of the entire arrangement. It is thus necessary to state a space group in terms of the equivalent positions which lie within a unit cell rather than by giving, as Schoenflies does, the equivalent positions about one point of the lattice underlying the grouping. This rather obvious modification has of course been made by those who have used the space groups as a guide in studying crystals. The second modification, or rather amplification, is not so readily made. The X-ray experiments which have already been carried out show that the number of particles (atoms) contained in the unit cell is commonly smaller than the number of most generally placed equivalent points of the space group having the symmetry of the crystal. The special arrangements of the equivalent points (upon axes, planes, and other elements of symmetry), whereby the number of most generally placed equivalent positions is reduced, are thus of great importance and it becomes essential to be able to state all of them in any particular case. Niggli† has already given the simpler of these special cases. For some time the writer has been engaged in working out all of them and the following tables are an expression of the results of these computations.

It was the original intention simply to state these results and to outline the method whereby they were obtained. The writer is firmly convinced, however, that sure and definite progress in this relatively new field of crystal structure can be realized only by making the fullest possible use of the added information which the theory of space-groups furnishes; and since any discussion of this theory is almost completely absent from work published in English, it has seemed worth while to add a brief introduction in order to give such details of the space groups and of their development as seem to furnish sufficient background for the appreciation of the importance of the theory in this new field of physical science.

---

\* *Krystalssysteme und Krystalstruktur* (Leipzig, 1891).

† *Geometrische Krystallographie des Discontinuums* (Leipzig, 1919).



At present a knowledge of the method of derivation is not required by the crystal analyst or by the person primarily interested in using the results of such X-ray studies. Those interested in the theory as a geometrical problem will of course find the development thoroughly given by Schoenflies. In the only publication available to English readers Hilton\* has summarized, in excellent form, the work of Schoenflies, introducing at the same time some of the methods of representation employed by Federov. A thorough understanding of the manner of developing the theory, however, is best attained from a study of the original work of Schoenflies. The discussion in the present book is intended for those who wish only to get a sufficient idea of the nature of the results of the theory of space-groups so that these results can be intelligently used.

For the substance of this discussion the writer's obligation to Schoenflies is obvious; the work of Hilton has also been used with entire freedom. In the book to which reference has already been made Niggli has given the positions within the unit cell (of each space-group) of all of its elements of symmetry. This information, while of no aid in the actual determination of the structures of crystals, may prove useful in the attempt to derive from these structures additional information, such as that bearing upon the internal symmetries of their constituent atoms. In comparing the partial analytical expression given by Niggli with his results based directly upon those of Schoenflies, the writer found that particularly in the case of the tetragonal space-groups there were many differences, owing chiefly to the choice of different points as the origin of coordinates. Because of the possible usefulness of the additional data relating to the positions of elements of symmetry that are furnished by Niggli, it has seemed desirable, in spite of some loss of logicality, to recalculate these groups so that they would accord with those already published. Similar differences exist in orthorhombic and monoclinic groups; the changes necessary to reconcile the two descriptions are in these cases sufficiently obvious, however, that it has seemed worth while only to indicate in some more or less illustrative instances the nature of the translations necessary to bring about a general coincidence.

The writer wishes to express his gratitude to Dr. S. Nishikawa for the advice and criticism given him when in 1917 he began to familiarize himself with the theory of space-groups.

GEOPHYSICAL LABORATORY,  
*March, 1921.*

---

\* *Mathematical Crystallography* (Oxford, 1903).

## CONTENTS.

	Page
CHAPTER I. Historical Introduction .....	1-3
CHAPTER II. Nature of the Space-Groups .....	4-38
Elements of Symmetry .....	4
Point-Groups .....	6
Analytical Representation of the Point-Groups:	
Triclinic System .....	11
Monoclinic System .....	12
Orthorhombic System .....	13
Tetragonal System .....	14
Cubic System .....	16
Hexagonal System .....	18
Space Lattices .....	22
Space-Groups .....	24
An Outline of the Derivation of the Space-Groups:	
Triclinic System .....	26
Monoclinic System .....	27
Orthorhombic System .....	27
Tetragonal System .....	30
Cubic System .....	33
Hexagonal System .....	35
CHAPTER III. The Application of the Theory of Space-Groups to Crystals .....	39-46
Units of Structure .....	39
Space-Groups and Crystals .....	42
Special Cases of the Space-Groups .....	44
The Treatment of Calcite as a Typical Case .....	45
CHAPTER IV. The Complete Analytical Expression of the Space-Groups .....	47-180
Triclinic System:	
A. Hemihedry, $C_1$ .....	48
B. Holohedry, $C_1$ .....	48
Monoclinic System:	
A. Hemihedry, $C_2$ .....	49
B. Hemimorphy, $C_2$ .....	49
C. Holohedry, $C_2^h$ .....	49
Orthorhombic System:	
A. Hemimorphy, $C_2^v$ .....	52
B. Hemihedry, $V$ .....	56
C. Holohedry, $V^h$ .....	59
Tetragonal System:	
A. Tetartohedry of the Second Sort, $S_4$ .....	73
B. Hemihedry of the Second Sort, $V^d$ .....	73
C. Tetartohedry, $C_4$ .....	79
D. Paramorphic Hemihedry, $C_4^h$ .....	80
E. Hemimorphic Hemihedry, $C_4^v$ .....	83
F. Enantiomorphic Hemihedry, $D_4$ .....	86
G. Holohedry, $D_4^h$ .....	89

Cubic System:	
The Special Cases of the Cubic System .....	103
A. Tetartohedry, $T$ .....	121
B. Paramorphic Hemihedry, $T^h$ .....	123
C. Hemimorphic Hemihedry, $T^d$ .....	128
D. Enantiomorphic Hemihedry, $O$ .....	132
E. Holohedry, $O^h$ .....	138
Hexagonal System—Rhombohedral Division:	
A. Tetartohedry, $C_3$ .....	151
B. Hexagonal Tetartohedry of the Second Sort, $C_3^d$ .....	151
C. Hemimorphic Hemihedry, $C_3^y$ .....	152
D. Enantiomorphic Hemihedry, $D_3$ .....	153
E. Holohedry, $D_3^h$ .....	155
Hexagonal System—Hexagonal Division:	
A. Trigonal Paramorphic Hemihedry, $C_3^h$ .....	157
B. Hemihedry with a Three-fold Axis, $D_3^h$ .....	158
C. Hexagonal Tetartohedry, $C_6$ .....	160
D. Hemimorphic Hemihedry, $C_6^y$ .....	161
E. Paramorphic Hemihedry, $C_6^h$ .....	162
F. Enantiomorphic Hemihedry, $D_6$ .....	163
G. Holohedry, $D_6^h$ .....	166
Summarizing Tables .....	170

## TABLES.

TABLE 1. A Comparison of Some Current Systems of Point-Group (Crystal Class) Nomenclature .....	10
TABLE 2. The Unit Cells of Each of the 14 Space Lattices .....	42
TABLES SUMMARIZING THE NUMBERS OF SPECIAL CASES OF SPACE-GROUPS HAVING THE SYMMETRY OF EACH OF THE SYSTEMS OF CRYSTAL SYMMETRY:	
TABLE 3. Triclinic System .....	170
TABLE 4. Monoclinic System .....	170
TABLE 5. Orthorhombic System .....	171
TABLE 6. Tetragonal System .....	174
TABLE 7. Cubic System .....	176
TABLE 8. Hexagonal System—Rhombohedral Division .....	178
TABLE 9. Hexagonal System—Hexagonal Division .....	179

---

---

**THE ANALYTICAL EXPRESSION OF  
THE RESULTS OF THE THEORY  
OF SPACE-GROUPS**

---

**BY RALPH W. G. WYCKOFF**

---

---



# CHAPTER I.

## HISTORICAL INTRODUCTION.\*

The investigation of the structure of crystals involves the study both of the substance from which the crystals are made and of the way in which this material is arranged in space. Until very recently, practically all of the information bearing upon the first of these points has arisen from the realization of the probable physical reality of the chemical atom. How these atoms are associated together in crystals and whether the chemical molecule, or some other aggregate of atoms, has the significance in solids which it possesses in gases and liquids are questions which have been answered only by conjecture and inference. The development in the other direction, however, presenting a problem which in its most general statement is independent of current hypotheses concerning the nature of the material from which crystals are built, has been capable on the other hand of a far-reaching and apparently satisfactory growth.

In the days when an atomic structure of matter was a crude working hypothesis without any basis in experimentally determined fact, we find Robert Hooke† reproducing the forms of alum by properly piling up "a company of bullets and some few other very simple bodies," very much as we represent the structure of a crystal on the basis of X-ray measurements.

It was the phenomenon of regular cleavage, however, that supplied the evidence upon which early hypotheses of the regular arrangement of the material of crystals were based. For instance, Westfeld‡ considered calcite as built up of tiny rhombohedrons; and Bergman,§ basing his beliefs partly on the observation of Gahn that a skalenohedron of calcite yields a rhombohedron on cleaving, developed what might be called the first geometrical theory of crystal structure. For just as the crystals of calcite could be considered as an aggregate of minute rhombohedrons placed parallel to one another, so garnet or pyrite or other crystals can be developed similarly from certain fundamental forms. These ideas seem to be essentially the same as those held by Hauy.¶ He, also, considered cleavage as the guiding factor. The cleavage units, his *molecules integrantes*, were either tetrahedra, triangular prisms, or parallelopipeda, and he showed how crystals with variously developed faces could be represented by the aggregation of these units. These ideas of Hauy were built around the law of rational indices, though they were fundamentally independent of it. Many objections to the details of the hypothesis of Hauy arose, as indeed they must arise against any theory based primarily upon cleavage. Not only does the existence of the many

---

\* Most of the material for this introduction is given by L. Sohncke, *Entwicklung einer Theorie der Krystallstruktur* (Leipzig, 1879). It is given in English and brought up to date in a report of the Brit. Assoc. 297-337. 1901.

† *Micrographia* (London, 1665), p. 85.

‡ *Mineralogische Abhandlungen*, Stück I. 1767.

§ *Nov. Acta. Reg. Soc. Sc. Upsal.* 1773, i; *Opusc. (Upsala)* 1780, ii.

¶ *Essai de Cristallographie* (Paris) 1772; etc.

crystals which show no cleavage necessitate many supplementary hypotheses, but the observed cleavage of such substances as fluorite (with octahedral cleavage) is not readily accounted for by any kind of close-fitting units.

Simultaneously with the extension of the belief in the atomic nature of substances, and perhaps because of this belief, emphasis came to be shifted from the shape of the crystal units to the relative positions of their centers of gravity as centers of some sort of crystal molecules. Thus there evolved from these different speculations the basis for a suitable geometrical study in the definite conception of a crystal as composed of units of undefined shape repeated in some regular fashion throughout space.

In such a regular pattern for repeating the crystal unit we have a *space lattice*. All of the symmetrical networks of points which can have crystallographic symmetry were found geometrically by Frankenheim.\* Some years later this was done more accurately and rigidly by Bravais.† As a result of his work, Bravais looked upon a crystal as built up by placing units of a suitable symmetry all in the same orientation at the points of one of these symmetrical networks. Thus the unit of a cubic crystal might have cubic or even tetrahedral symmetry, but it could not, for instance, have monoclinic or hexagonal symmetry. As a matter of fact, Bravais thought of his units as groups of atoms forming some sort of a crystal molecule, though such a view is not a necessary part of the geometrical development. In this theory of Bravais, in which a crystal is composed of aggregates of atoms repeated regularly and indefinitely through space, is to be found the beginning of an adequate treatment of the possible groupings of matter in crystalline bodies. The objections to Bravais' theory, however, are many and obvious. In the first place, all of the space lattices have the complete symmetry of some one of the crystal systems, so that, in order to account for the lower degrees of symmetry, it was necessary for him to ascribe the degradation in such cases to the shape of the crystal units, or molecules, without at the same time being able satisfactorily to treat these units. Again this theory implies a distinct restriction, and one which had not been proved necessary, that all of the crystal molecules must have the same orientation throughout the crystal.

In the course of a general study of the theory of groups of movements Jordan‡ gave a perfectly general method for defining all of the possible ways of regularly repeating an identical grouping of points indefinitely throughout space. By combining this treatment of Jordan with the principle (laid down by Wiener) that regularity in the arrangement of identical atoms is attained when "every atom has the other atoms arranged about it in the same fashion," Sohncke§ eventually deduced all of the typical ways of regularly repeating identical groupings of atoms throughout space so that the

---

\* Die Lehre von der Cohäsion (Breslau, 1835).

† Journ. de l'École Polytech. (Paris) XIX, 127. 1850; XX, 102. 1851.

‡ Annali di matematica pura ed applicata (2) 2, 167, 215, 322. 1860.

§ L. Sohncke, op. cit.

total assemblage will possess crystallographic symmetry.\* This method of treatment in attacking the problem of the arrangement of the points within what was the crystal unit or molecule of Bravais brings the problem towards its final solution.

None of the systems of Sohncke can be made to account in an entirely satisfactory manner for the enantiomorphic (mirror-image) characteristics of many crystals. Schoenflies† was led to consider that every point of an assemblage must have all of the other points ranged about it in a "like fashion," where "likeness" may refer either to an identical arrangement or to a mirror-image similarity. Starting from this basis, he obtained the 230 space groups which represent all of the possible typical ways of arranging (symmetry-less) points in space so that the grouping will possess the symmetry of one of the thirty-two crystal classes. The same derivation of the space groups was accomplished independently by Federov‡ and by Barlow, but at present the work of Schoenflies is the most useful because it is presented in a form that is of immediate application. With the aid of this final theory of space groups the different degrees of symmetry exhibited by crystals can at last be traced back definitely and precisely to the arrangement of the atoms in the crystals (without postulating any characteristics of symmetry for them).

Besides indicating the elements of symmetry which are characteristic of each of the 230 typical ways of arranging points in space, Schoenflies gives, in general terms, the coordinates of the points in each of these groupings which are equivalent to one another.

The discovery of the diffraction of X-rays and the consequent development of the physical methods for studying the structure of crystals have made this analytical expression of the results of the theory of space groups of the utmost importance. It is the purpose of the present work to give these results a detailed expression, thereby putting them into a form in which they will be immediately useful as an aid to the study of the arrangement of the atoms in crystals. X-ray experimentation thus far carried out shows that the special cases which result when equivalent points (the atoms in crystals) lie in some element or elements of symmetry, such as axes or planes, are the ones which are physically most important. As a consequence the preparation of this detailed expression, in so far as it introduces material which is not outlined in the work of Schoenflies, has made necessary the working out of all of these special cases for all of the space-groups.

---

\* At first Sohncke seems to have been inclined to view all of the points of a point system as regular and all of one kind. When the insufficiency of this theory was emphasized he postulated the presence of a few different kinds of points (which can be made to correspond with different kinds of atoms). The partial grouping composed of the points of any one kind is homogeneous; at the same time the different groupings all have the axes and the other elements of symmetry in common.

† A. Schoenflies. *Krystallsysteme u. Krystalstruktur* (Leipzig, 1891).

‡ E. Federov. *Z. Kryst.* *24*, 209. 1895; W. Barlow. *Z. Kryst.* *23*, 1. 1894. Federov's work appeared, in Russian, before that of either of the other two.



## CHAPTER II.

### NATURE OF THE SPACE - GROUPS.

#### ELEMENTS OF SYMMETRY.

*Axes of symmetry.*—An axis of rotation of a figure\* is a line about which the figure can be rigidly turned. The angle of the rotation is the angle between the final and initial positions of a plane which contains the axis of rotation. A figure is said to possess an axis of symmetry when rotation through a definite angle about an axis of rotation will cause the figure to assume the same point-for-point configuration that it originally possessed. The angle of the rotation about an axis which is required to bring about this coincidence is called the angle of the axis of symmetry. Every figure has an infinite number of  $2\pi$  axes of symmetry; that is, a complete rotation of  $360^\circ$  about any line through a body will cause it to assume its original configuration. The operation of such a  $2\pi$  (one-fold) axis is called the identical operation of symmetry (or simply the identity). If a rotation of  $180^\circ$  is sufficient to effect a coincidence, the axis of rotation is a  $180^\circ$ , or two-fold axis of symmetry; more generally, an  $n$ -fold axis of symmetry is one for which a rotation of angle  $\frac{2\pi}{n}$  brings about coincidence. One-, two-, three-, four- and six-fold axes are found in crystals (and in figures possessing crystallographic symmetry). (Figure 1.)

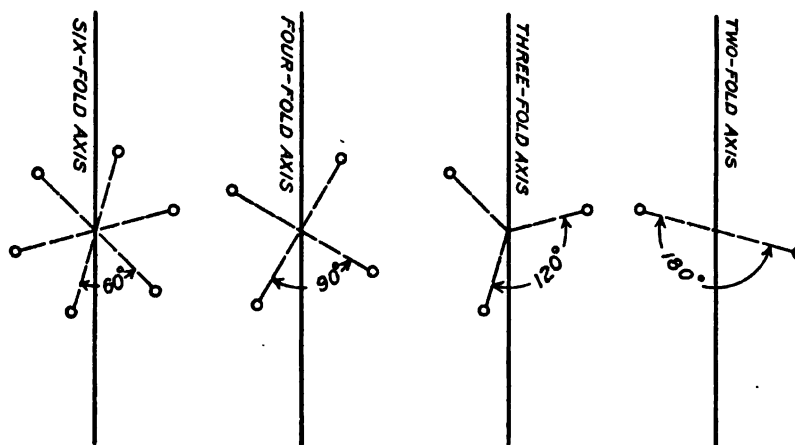

FIG. 1. The crystallographically significant rotational axes of symmetry.

*Plane of symmetry.*—In figure 2 the line  $POP'$  is perpendicular to the plane  $ABCD$ . If then  $PO$  equals  $OP'$  in length, the point  $P'$  stands in a mirror-image relation to the point  $P$ . If a plane can be passed through a figure so that every point of the figure upon one side of this plane has a corresponding

\* By a figure is meant any sort of a collection of points, lines, planes, and so on.

point in a mirror-image position upon the other side of the plane, the plane is a plane of symmetry.

*Center of symmetry.*—A point of a figure is a center of symmetry if a line drawn from any point of the figure to it and extended an equal distance beyond will encounter a point corresponding to the arbitrarily chosen point. (Figure 3.)

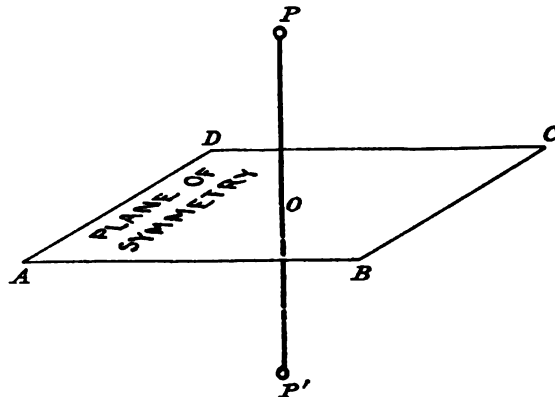

FIG. 2.

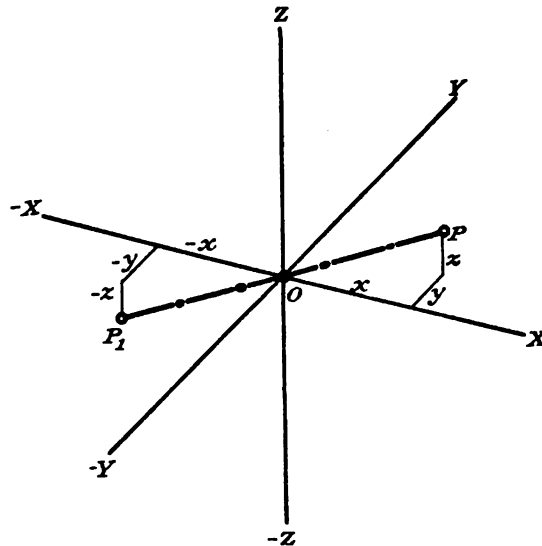

FIG. 3. O is the center of symmetry of a figure in which P and  $P_1$  are corresponding points.

*Screw-axes of symmetry.*—A figure is said to experience a translation when every point of the figure is moved by the same amount in the same direction. A rotation about an axis accompanied by a translation along the axis of rotation is called a rotary translation. This screw-motion must be defined

both by the angle of the rotation and by the amount of the translation. The axis of the rotation (and the line of the translation) is called a screw-axis. If such a rotary translation will bring the points of a figure into co-

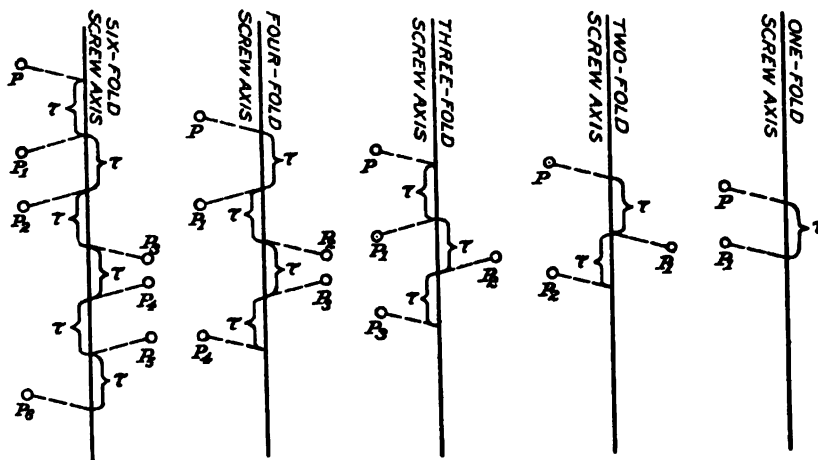

FIG. 4. The crystallographically significant screw axes of symmetry.

incidence, the axis of the motion is a screw-axis of symmetry. In a figure having crystallographic symmetry these screw-axes may be one-, two-, three-, four- or six-fold. (Figure 4.)

*Glide planes of symmetry.*—If a figure can be brought into point-for-point coincidence by a reflection in a plane combined with a translation of a definite length and direction in the plane, the plane is called a glide plane of symmetry. In this case the translation-reflection must be defined both by the position of the plane and by the length and direction of the translation. (Figure 5.)

#### POINT-GROUPS.

The thirty-two ways of suitably combining these planes, axes, and centers of symmetry give the elements of symmetry which are characteristic of the 32 classes of crystallographic symmetry. Each one of these combinations of symmetry elements is a point-group. Thus, a point-group may be defined by stating either the elements or operations\* of symmetry which characterize it.

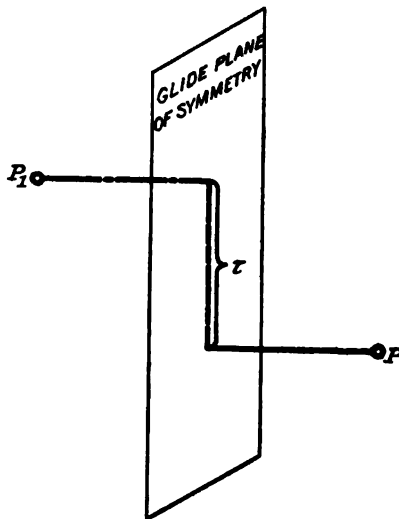

FIG. 5.  $P_1$  is a glide reflection of  $P$  in the plane shown in the figure.

\* By an operation of symmetry is meant any movement which will bring about a point-for-point coincidence. For instance, a six-fold axis of rotation possesses six operations of symmetry

The elements of symmetry characteristic of each of the 32 point-groups will now be given.

The cyclic groups have only one axis of symmetry. They may be written symbolically as

$$C_n = \left\{ A \left( \frac{2\pi}{n} \right) \right\},$$

where  $n$  may be either 1, 2, 3, 4 or 6.  $A$  will be taken as the symbol of a rotation so that the term within the braces is to be considered as defining a rotation of angle  $\frac{2\pi}{n}$ .

Diëder-groups have one principal axis of symmetry of angle  $\frac{2\pi}{n}$  and  $n$  two-fold axes in a plane at right angles to the principal axis.

$$D_n = \left\{ A \left( \frac{2\pi}{n} \right), U \right\},$$

where  $U$  (Umklappung) will be used to represent the two-fold rotation of the secondary axes. The value of  $n$  may be 1, 2, 3, 4 or 6. The group  $D_1$  is clearly identical with  $C_2$ , however. The positions of the axes of the other groups are shown in figure 6. The group for which  $n=2$  furnishes the special case of three two-fold axes at right angles to one another; this group is more commonly known as the vierer-group and is designated as  $V$ .

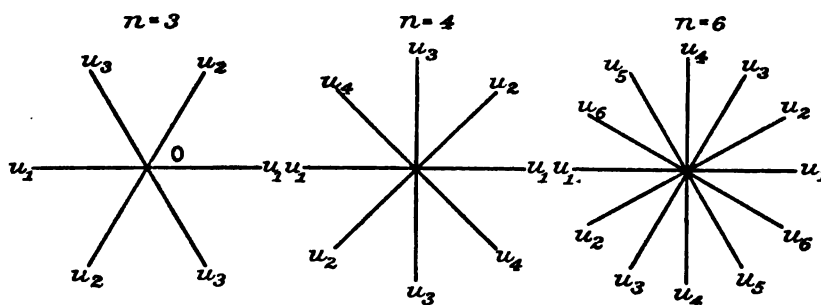

FIG. 6.

The tetrahedral group (symbol= $T$ ) has 3 two-fold axes at right angles to one another (like the vierer-group) and 4 three-fold axes so placed that if the two-fold axes are taken to bisect the sides of a circumscribed tetrahedron, the 4 three-fold axes will each one pass through the point of intersection of the two-fold axes and through one of the corners of the tetrahedron (figure 7).

The octahedral group (symbol= $O$ ) has 3 four-fold, 4 three-fold, and 6 two-fold axes arranged in the same manner as are the altitudes, the body-diagonals, and the face-diagonals of a cube (figure 8).

The groups which have so far been considered require only simple rotation axes for their expression; they are commonly called groups of the first sort. Those that now follow are groups of the second sort.

Cyclic groups of the second sort possess one screw-axis of symmetry

$$\bar{C}_n = \left\{ \bar{A} \left( \frac{2\pi}{n} \right) \right\},$$

where the symbol in brackets may be taken as a rotary translation of angle  $\frac{2\pi}{n}$ . The value of  $n$  may be 1, 2, 3, 4 or 6. When  $n=1$  the rotary translation is clearly equivalent to a reflection in a plane at right angles to the axis of rotation. Thus, in figure 9A the rotary translation of angle  $2\pi$  will bring the point  $P$  to the position  $P_1$ ; this operation is, however, equivalent to a

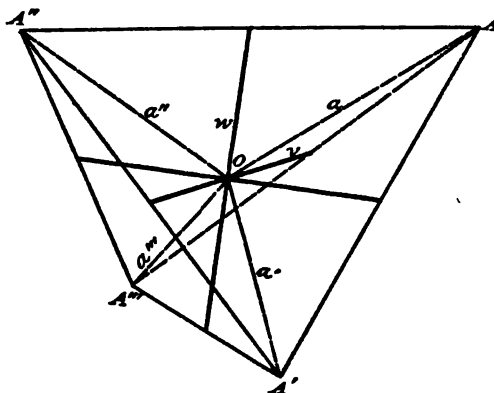

FIG. 7.

reflection in the plane through  $O$  normal to  $pp'$ , where  $Op$  is equal to one-half of the length  $\tau$  of the translation component of the rotary translation. When  $n=2$ , the resulting rotary translation  $Op$  is equivalent to an inversion through the point  $O$  of figure 9b. These two groups may thus be written

$$\bar{C}_1 = \{ \bar{A}(2\pi) \} = \{ S \} \quad \text{and} \quad \bar{C}_2 = \{ \bar{A}(\pi) \} = \{ I \}$$

where  $S$  (Spiegelung) stands for a reflection and  $I$  for an inversion. In a similar fashion it will be seen that when  $n=4$ , this group is identical with one obtained by combining a rotation  $A\left(\frac{\pi}{2}\right)$  with a reflection  $S_h$  in a horizontal plane of symmetry. Thus

$$\bar{C}_4 = \left\{ \bar{A} \left( \frac{\pi}{2} \right) \right\} = \left\{ A \left( \frac{\pi}{2} \right), S_h \right\} = S_4.$$

Other groups of the second sort can be obtained by combining a principal axis of rotation with a plane or with a center of symmetry. Three types of such groups having but one axis of symmetry are possible: (1) when the plane of symmetry is normal to the axis of symmetry (a horizontal reflecting plane), (2) when the plane of symmetry contains the axis of symmetry (a vertical

reflecting plane) and (3) when the new element of symmetry is a center of symmetry. These three types may then be written

$$(1) C_n^h = \{C_n, S_h\} \quad (2) C_n^v = \{C_n, S_v\} \quad (3) C_n^i = \{C_n, I\}$$

It can be shown that if  $n$  is odd, all three of these types are possible. When, however,  $n$  is even, the number of different groups for any value of  $n$  is but two. The groups of this sort that are thus possible are the following:

When  $n=1$ .—The group  $C_1^i$  is clearly the same as the group  $C_1^v$ ; furthermore it is identical with the group  $\bar{C}_1$ . Similarly the group  $C_1^h$  is identical with the group  $\bar{C}_2$ .

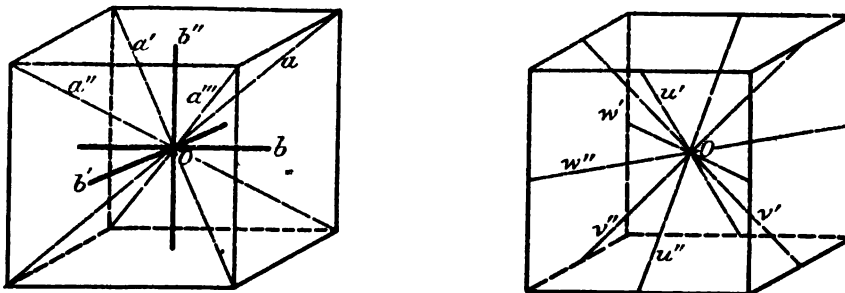

FIG. 8.

When  $n=2, 4$  or  $6$ .— $C_n^h = C_n^i$ , so that groups of the types  $C_n^h = C_n^i$  and  $C_n^v$  are possible.

When  $n=3$ .—Point-groups of all three types are possible.

Some new groups arise by combining the axes of a group of the type  $D_n$  with a reflection plane. The plane of symmetry may lie in the horizontal position (normal to the principal axis of symmetry); if it lies in the vertical position new groups will be obtained only when the plane bisects the angle between secondary axes (a diagonal plane). It can furthermore be shown that in the latter case groups of crystallographic significance will be obtained only when  $n=2$  and when  $n=3$ . Thus, when  $n=2, 3, 4$ , or  $6$ , we have the new groups

$$D_2^h = V^h, \quad D_3^d = V^d, \quad D_4^d, \quad D_6^h,$$

The groups  $T^h$  and  $T^d$  arise from the tetrahedral group,  $T$ , by combining the axes of  $T$  with a horizontal and with a diagonal-vertical reflecting plane, respectively. One new group,  $O^h$ , can be produced from the octahedral group  $O$ .

All of the 32 groups have now been defined. On the basis of their total symmetry these 32 point-groups can be placed in 6 (or 7) systems, the systems of crystallographic symmetry.\* This classification of the point-groups is given in Table 1, together with the names of the classes of crystal symmetry (according to Schoenflies, Dana, and Groth) corresponding to each.

\* A basis for this classification will become evident when the point-groups are discussed separately and given an analytical expression.

TABLE 1.

Symbol.	Class of symmetry.			No. of operations of symmetry and of equivalent points.
	SCHÖENFLIES.	DANA.	GAOPE.	
1. $C_1$	I. Triclinic system: Hemihedry	Asymmetric	Asymmetric pedial	1
2. $\bar{C}_2 = S_2 = C_1$	Holohedry	Normal	Pinacoidal	2
3. $\bar{C}_2 = C_2^h = C_2$	II. Monoclinic system. Hemihedry	Clinohedral	Domatic	2
4. $C_2$	Hemimorphic hemihedry	Hemimorphic	Monoclinic sphenoidal	2
5. $C_2^h$	Holohedry	Normal	Monoclinic prismatic	4
6. $C_2^v$	III. Orthorhombic system. Hemimorphic hemihedry	Hemimorphic	Rhombic pyramidal	4
7. $D_2 = V$	Enantiomorphic hemihedry	Sphenoidal	Rhombic bisphenoidal	4
8. $D_2^h = V^h$	Holohedry	Normal	Rhombic bipyramidal	8
9. $S_4 = \bar{C}_4$	IV. Tetragonal system. Tetartohedry of second sort	Tetartohedral	Tetragonal bisphenoidal	4
10. $V^d = D_2^d$	Hemihedry of second sort	Sphenoidal	Tetragonal scalenohedral	8
11. $C_4$	Tetartohedry	Pyramidal hemimorphic	Tetragonal pyramidal	4
12. $C_4^h$	Paramorphic hemihedry	Pyramidal	Tetragonal bipyramidal	8
13. $C_4^v$	Hemimorphic hemihedry	Hemimorphic	Ditetragonal pyramidal	8
14. $D_4$	Enantiomorphic hemihedry	Trapezohedral	Tetragonal trapezohedral	8
15. $D_4^h$	Holohedry	Normal	Ditetragonal bipyramidal	16
16. T	V. Cubic system. Tetartohedry	Tetartohedral	Tetrahedral pentagonal dodecahedral	12
17. $T^h$	Paramorphic hemihedry	Pyritohedral	Diaesdodecahedral	24
18. $T^d$	Hemimorphic hemihedry	Tetrahedral	Hexaistetrahedral	24
19. O	Enantiomorphic hemihedry	Plagihedral	Pentagonalicositetrahedral	24
20. $O^h$	Holohedry	Normal	Hexaicosahedral	48
21. $C_3$	VI. Hexagonal system. Tetartohedry	<i>Rhombohedral Division</i> 24.	Trigonal pyramidal ✓	3
22. $C_3^i$	Hexagonal tetartohedry of second sort	Trirhombohedral	Rhombohedral ✓	6
23. $C_3^v$	Hemimorphic hemihedry	Ditrigonal pyramidal	Ditrigonal pyramidal ✓	6
24. $D_3$	Enantiomorphic hemihedry	Trapezohedral	Trigonal trapezohedral ✓	6
25. $D_3^d$	Holohedry	Rhombohedral	Ditrigonal scalenohedral ✓	12
26. $C_3^h$	Trigonal paramorphic hemihedry	<i>Hexagonal Division</i> 23.	Trigonal bipyramidal ✓	6
27. $D_3^h$	Trigonal holohedry	Trigontype	Ditrigonal bipyramidal ✓	12
28. $C_6$	Tetartohedry	Pyramidal hemimorphic	Hexagonal pyramidal ✓	6
29. $C_6^h$	Paramorphic hemihedry	Pyramidal	Hexagonal bipyramidal ✓	12
30. $C_6^v$	Hemimorphic hemihedry	Hemimorphic	Dihexagonal pyramidal ✓	12
31. $D_6$	Enantiomorphic hemihedry	Trapezohedral	Hexagonal trapezohedral ✓	12
32. $D_6^h$	Holohedry	Normal	Dihexagonal bipyramidal ✓	24

NOTE.—It may be remarked that the numbers of the first column have no particular significance and do not refer to any of the current systems of designating symmetry classes.

*The analytical expression of the point-groups.*—On the basis of the definitions of the 32 point-groups, the operations of symmetry (footnote on page 6) that characterize each of them can be immediately written. Furthermore, it is evident that if any point,  $x, y, z$ , is subjected to each of the operations of a point-group, a group of equivalent points will result whose symmetry is

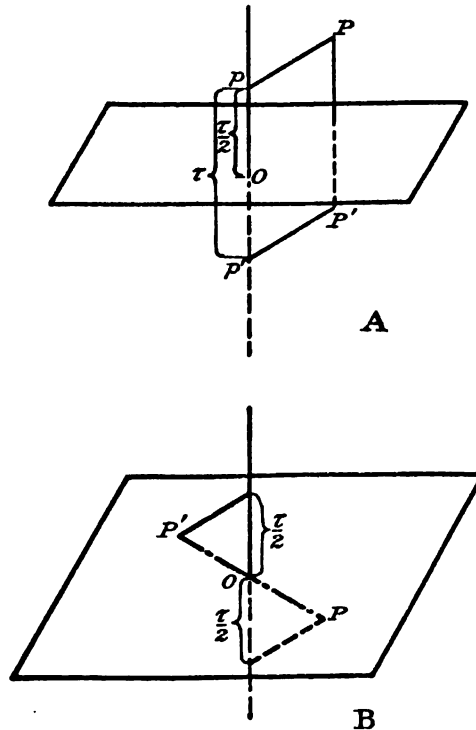

FIG. 9.

that of the point-group; thus its analytical expression is obtained. The operations of symmetry which are characteristic of each of the point-groups will now be stated and through them analytical representations given to each of these groups.

#### TRICLINIC SYSTEM.

*Point-group  $C_1$ .*—This group has but one element of symmetry, the identical operation (symbol=1). Since the identity brings any point  $x, y, z$  into coincidence with itself, any single point,  $xyz$ , serves as an analytical representation of this group. The coordinate axes to which these coordinates refer obviously can be any three lines in space, of unequal unit lengths and making unequal angles with one another. Such axes will be called the triclinic axes of reference. They are equally serviceable for the point-group,  $C_1$ , which follows.

*Point-group  $C_i$ .*—The operations of symmetry characteristic of this group are the identity (obviously an operation of every group) and an inversion



(symbol= $I$ ). Since an inversion through the origin of coordinates changes the signs of all three coordinates (figure 3) the operations of symmetry and the coordinates of equivalent points of this point-group are

Operations of symmetry:  $1, I.$   
 Coordinates of equivalent points:  $xyz; \bar{x}\bar{y}\bar{z}.$

#### MONOCLINIC SYSTEM.

In their analytical expressions all of the point-groups having the symmetry of this system can be referred to a system of axes, two of which (the X- and Y-axes) make any angles with one another; the third axis (the Z-axis) is normal to the plane of these other two. The Z-axis consequently is taken to coincide with the principal two-fold axis, where such exists.

*Point-group  $C_s$ .*—The single operation of symmetry (besides the identity) of this group is a reflection to be taken in the horizontal (XY-) plane. Since such a reflection (symbol= $S_h$ ) changes the sign of the z-coordinate (figure 10), the operations and equivalent and equivalent points of this group are

Operations of symmetry:  $1, S_h.$   
 Coordinates of equivalent points:  $xyz; xy\bar{z}.$

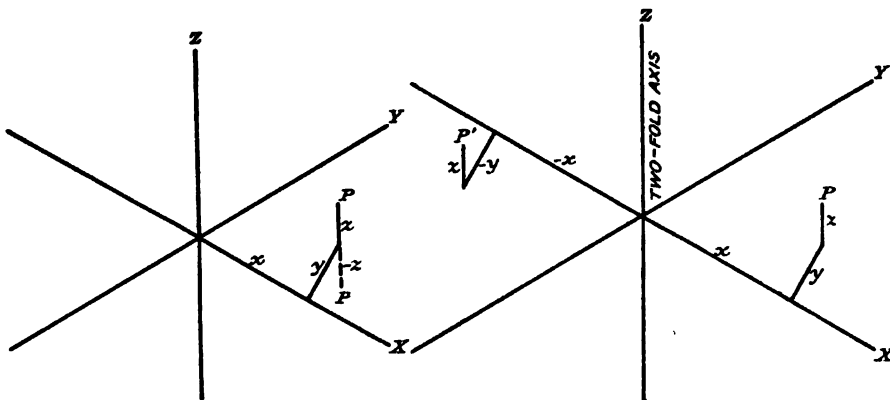

FIG. 10.

FIG. 11.

*Point-group  $C_2$ .*—A two-fold rotation about an axis (the Z-axis) normal to the plane of the other two axes of coordinates, changes the signs of these two coordinates (figure 11). Consequently the point-group  $C_2$  can be expressed as

Operations of symmetry:  $1, A(\pi).$   
 Coordinates of equivalent points:  $xyz; \bar{x}\bar{y}z.$

*Point-group  $C_2^h$ .*—Since this group is developed by mirroring  $C_2$  in a horizontal (XY-) plane of symmetry, it is to be expressed as follows:

Operations of symmetry:  $1, A(\pi), S_h, A(\pi)S_h.$

The operation whose symbol is  $A(\pi)S_h$ , the product of  $A(\pi)$  and  $S_h$ , is to

be understood as a two-fold rotation followed by a reflection in the horizontal plane.\*

Coordinates of equivalent points.  $xyz$ ;  $\bar{x}\bar{y}z$ ;  $xy\bar{z}$ ;  $\bar{x}y\bar{z}$ .

ORTHORHOMBIC SYSTEM.

The orthorhombic axes of reference are three mutually perpendicular axes of unequal unit lengths.

*Point-group C<sub>2</sub>*.—Since reflection in a plane containing two of the axes of reference and normal to the third changes the sign of the coordinate value for the third (confer C<sub>2</sub><sup>v</sup>), this point-group may be expressed as

Operations of symmetry: 1, A( $\pi$ ), S<sub>v</sub>, S<sub>v</sub>A( $\pi$ ).

S<sub>v</sub> is a reflection in a vertical plane (taken through Y and Z).

Coordinates of equivalent points:  $xyz$ ;  $\bar{x}\bar{y}z$ ;  $\bar{x}yz$ ;  $x\bar{y}z$ .

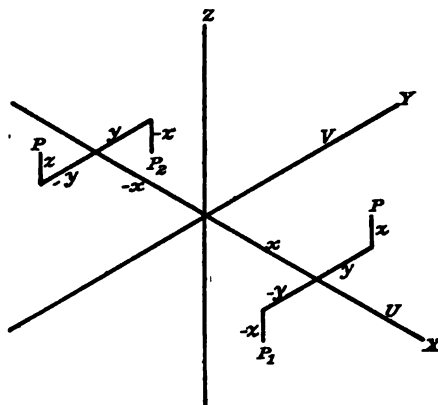

FIG. 12.

*Point-group V*.—The rotations about the three mutually perpendicular two-fold axes will be designated as U, V, and W (figure 12).

Operations of symmetry:

1, U, V, W.

Coordinates of equivalent points:

$xyz$ ;  $x\bar{y}\bar{z}$ ;  $\bar{x}y\bar{z}$ ;  $\bar{x}\bar{y}z$ .

*Point-group V<sup>h</sup>*.—As usual, the XY-plane is taken as the horizontal mirroring plane.

Operations of symmetry:

1, U, V, W, S<sub>h</sub>, US<sub>h</sub>, VS<sub>h</sub>, WS<sub>h</sub>.

Coordinates of equivalent points:

$xyz$ ;  $x\bar{y}\bar{z}$ ;  $\bar{x}y\bar{z}$ ;  $\bar{x}\bar{y}z$ ;  $xy\bar{z}$ ;  $x\bar{y}z$ ;  $\bar{x}yz$ ;  $\bar{x}\bar{y}z$ .

\* The order of combining the operations in such a product is immaterial. It could equally well have been called a reflection followed by a two-fold rotation.

## TETRAGONAL SYSTEM.

The three tetragonal axes of reference, mutually perpendicular to one another, are two (the X- and the Y-axes) of equal unit length.

*Point-group*  $\bar{C}_4 = S_4$ .—

Operations of symmetry:

$$1, \quad S_4 A\left(\frac{\pi}{2}\right), \quad A(\pi)^*, \quad S_4 A\left(\frac{3\pi}{2}\right).$$

Coordinates of equivalent points:

$$xyz; \quad \bar{y}x\bar{z}; \quad \bar{x}\bar{y}z; \quad y\bar{x}\bar{z}.$$

*Point-group*  $C_4$ .—As we have just seen, the rotation of angle  $\frac{\pi}{2}$  about the Z-axis interchanges the X and Y coordinates and leaves the new X-coordinates reversed in sign (figure 13).

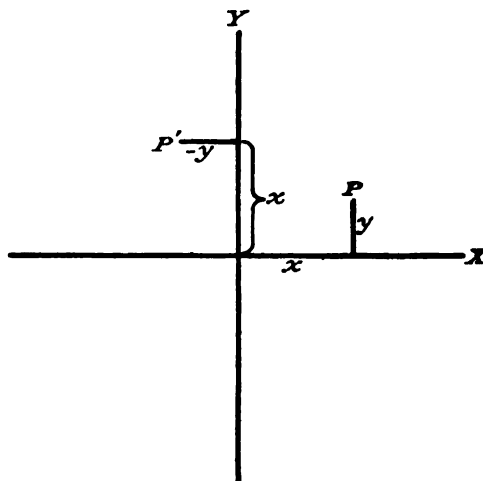

FIG. 13.

Operations of symmetry:

$$1, \quad A\left(\frac{\pi}{2}\right), \quad A(\pi), \quad A\left(\frac{3\pi}{2}\right).$$

Coordinates of equivalent points:

$$xyz; \quad \bar{y}xz; \quad \bar{x}\bar{y}z; \quad y\bar{x}z.$$

*Point-group*  $V^d$ .—The diagonal reflecting plane contains the Z-axis and bisects the angle between the X- and Y-axis. Reflection in such a plane ( $S_d$ ) interchanges the X- and Y-coordinates (figure 14).

Operations of symmetry.

$$1, \quad U, \quad V, \quad W, \quad S_d, \quad US_d, \quad VS_d, \quad WS_d.$$

Coordinates of equivalent points.:

$$xyz; \quad x\bar{y}\bar{z}; \quad \bar{x}y\bar{z}; \quad \bar{x}\bar{y}z; \quad yxz; \quad \bar{y}x\bar{z}; \quad y\bar{x}\bar{z}; \quad \bar{y}\bar{x}z.$$

\* This arises from the observation that two reflections in the same plane nullify one another.

*Point-group*  $C_4^h$ .—

Operations of symmetry:

$$1, A\left(\frac{\pi}{2}\right), A(\pi), A\left(\frac{3\pi}{2}\right), S_h, S_hA\left(\frac{\pi}{2}\right), S_hA(\pi), S_hA\left(\frac{3\pi}{2}\right).$$

This may be more conveniently written as  $C_4^h = \{C_4, S_h\}$ , signifying that the operations of  $C_4^h$  are those of  $C_4$  plus the reflections of these operations in the horizontal plane.\*

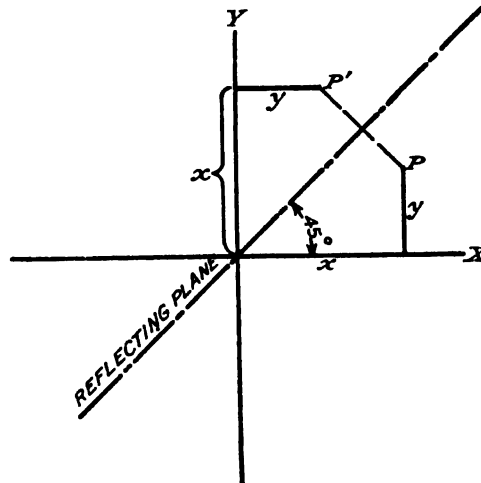

FIG. 14.

Coordinates of equivalent points:

$$xyz; \quad \bar{y}xz; \quad \bar{x}\bar{y}z; \quad y\bar{x}z; \quad xy\bar{z}; \quad \bar{y}x\bar{z}; \quad \bar{x}\bar{y}\bar{z}; \quad y\bar{x}\bar{z}.$$

These coordinates illustrate the fact, of which use will commonly be made in the work which follows, that a two-fold rotation about an axis combined with a reflection in a plane normal to the axis is equivalent to an inversion (figure 15). Thus  $C_4^h = \{C_4, I\}$  is an alternative expression of the point-group  $C_4^h$ . In this latter case the coordinates of equivalent points would be written in the following order.

$$xyz; \quad \bar{y}xz; \quad \bar{x}\bar{y}z; \quad y\bar{x}z; \quad \bar{x}\bar{y}\bar{z}; \quad y\bar{x}\bar{z}; \quad xy\bar{z}; \quad \bar{y}x\bar{z}.$$

*Point-group*  $C_4^v$ .—

Operations of symmetry:

$$C_4 = \{C_4, S_v\}.$$

$S_v$  is again a mirroring in the vertical, YZ-plane.

Coordinates of equivalent points:

$$xyz; \quad \bar{y}xz; \quad \bar{x}\bar{y}z; \quad y\bar{x}z; \quad \bar{x}yz; \quad yxz; \quad \bar{x}\bar{y}\bar{z}; \quad \bar{y}\bar{x}\bar{z}.$$

*Point-group*  $D_4$ .—The four two-fold axes lying in the XY-plane coincide with the X- and Y-axes and bisect the angles between them (figure 6). The

\* In the future this abbreviated representation will be used when no ambiguities are thereby introduced.

operations of symmetry of  $D_4$  may consequently be obtained by applying the operations of one of the two-fold axes (the one coinciding with the X-axis will be employed) to those of  $C_4$ .

Operations of symmetry:

$$D_4 = \{C_4, U\}.$$

Coordinates of equivalent points:

$$xyz; \quad \bar{y}xz; \quad \bar{x}\bar{y}z; \quad y\bar{x}z; \quad x\bar{y}\bar{z}; \quad \bar{y}\bar{x}\bar{z}; \quad \bar{x}y\bar{z}; \quad yxz.$$

If other two-fold axes were used, the order of the last four coordinate values would be changed.

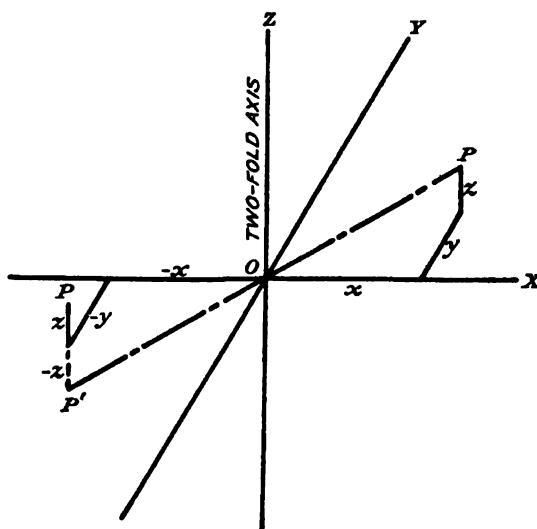

FIG. 15.

*Point-group*  $D_4^h$ .—

Operations of symmetry:

$$D_4^h = \{D_4, S_8\} = \{D_4, I\}.$$

Coordinates of equivalent points:

$$\begin{array}{cccccccc} xyz; & \bar{y}xz; & \bar{x}\bar{y}z; & y\bar{x}z; & x\bar{y}\bar{z}; & \bar{y}\bar{x}\bar{z}; & \bar{x}y\bar{z}; & yxz; \\ xy\bar{z}; & \bar{y}x\bar{z}; & \bar{x}\bar{y}\bar{z}; & y\bar{x}\bar{z}; & x\bar{y}z; & \bar{y}\bar{x}z; & \bar{x}yz; & yxz. \end{array}$$

#### CUBIC SYSTEM.

The cubic axes of reference are three mutually perpendicular axes with units all of the same length.

*Point-group* T.—

Operations of symmetry:

$$\begin{array}{cccc} 1, & U, & V, & W, \\ A\left(\frac{2\pi}{3}\right), & A_1\left(\frac{2\pi}{3}\right), & A_2\left(\frac{2\pi}{3}\right), & A_3\left(\frac{2\pi}{3}\right), \\ A\left(\frac{4\pi}{3}\right), & A_1\left(\frac{4\pi}{3}\right), & A_2\left(\frac{4\pi}{3}\right), & A_3\left(\frac{4\pi}{3}\right). \end{array}$$

$A, A_1, A_2, A_3$  are rotations about the trigonal axes of  $a, a_1, a_2, a_3$  of figure 7.  
Coordinates of equivalent points:

$$I. \begin{cases} xyz; & x\bar{y}\bar{z}; & \bar{x}y\bar{z}; & \bar{x}\bar{y}z; \\ zxy; & \bar{z}\bar{x}\bar{y}; & \bar{z}\bar{x}y; & z\bar{x}\bar{y}; \\ yzx; & \bar{y}\bar{z}\bar{x}; & y\bar{z}\bar{x}; & \bar{y}z\bar{x}; \end{cases}$$

*Point-Group T<sup>h</sup>.*—

Operations of symmetry:

$$T^h = \{T, S_h\} = \{T, I\}.$$

In writing the coordinates of equivalent points the second of the representations will be used.

Coordinates of equivalent points: The 12 coordinate positions of T, and

$$II. \begin{cases} \bar{x}\bar{y}\bar{z}; & \bar{x}yz; & x\bar{y}z; & xy\bar{z}; \\ \bar{z}\bar{x}\bar{y}; & z\bar{x}y; & zxy; & \bar{z}xy; \\ \bar{y}\bar{z}\bar{x}; & y\bar{z}\bar{x}; & \bar{y}zx; & y\bar{z}x. \end{cases}$$

*Point-group T<sup>d</sup>.*—The diagonal mirroring plane is taken to bisect the angle between the X- and Y-axes.

Operations of symmetry:

$$T^d = \{T, S_d\}.$$

Coordinates of equivalent points: The 12 coordinate positions of T, and

$$III. \begin{cases} yxz; & \bar{y}x\bar{z}; & y\bar{x}\bar{z}; & \bar{y}\bar{x}z; \\ xzy; & x\bar{z}\bar{y}; & \bar{x}\bar{z}y; & \bar{x}z\bar{y}; \\ zyx; & \bar{z}\bar{y}\bar{x}; & \bar{z}y\bar{x}; & z\bar{y}\bar{x}. \end{cases}$$

*Point-group O.*—

Operations of symmetry: The 12 operations of T, and

$$\begin{array}{llll} U_1, & U_2, & B\left(\frac{\pi}{2}\right) & B\left(\frac{3\pi}{2}\right), \\ V_1, & V_2, & B_1\left(\frac{\pi}{2}\right), & B_1\left(\frac{3\pi}{2}\right), \\ W_1, & W_2, & B_2\left(\frac{\pi}{2}\right), & B_2\left(\frac{3\pi}{2}\right). \end{array}$$

Rotations about the various axes of figure 8 are represented by the corresponding capital letters. The four-fold axes  $b, b_1$  and  $b_2$  have the positions of  $u, v$  and  $w$  of figure 7.

Coordinates of equivalent positions: The 12 coordinate positions of T, and

$$IV. \begin{cases} \bar{y}\bar{x}\bar{z}; & y\bar{x}z; & \bar{y}xz; & yxz; \\ \bar{x}\bar{z}\bar{y}; & \bar{x}zy; & xz\bar{y}; & x\bar{z}y; \\ \bar{z}\bar{y}\bar{x}; & zy\bar{x}; & z\bar{y}x; & \bar{z}yx.* \end{cases}$$

---

\* The order of writing these coordinates has been changed about to make it conform with its later uses.

*Point-group*  $O_h$ .—

Operations of symmetry:

$$O_h = \{O, S_6\} = \{O, I\}.$$

Coordinates of equivalent positions: The 48 coordinate positions of I, II, III, and IV.

## HEXAGONAL SYSTEM.

## RHOMBOHEDRAL DIVISION.

The point-groups of this division will be described in terms of two kinds of axes of reference. The rhombohedral axes (1), all of the same unit length and making equal angles with one another, are arranged symmetrically about the three-fold axis (figure 16). Two of the hexagonal set of axes (2) are of equal unit lengths and make an angle of  $120^\circ$  with one another (figure 17); the third, the Z-axis, is of a different unit length and is normal to the plane of the X- and Y-axes. This second set is thus a special case of the monoclinic axes; the cubic axes, on the other hand, are a special case of the rhombohedral (1) axes. Coordinates according to the rhombohedral axes are given below under I, according to the hexagonal axes under II.

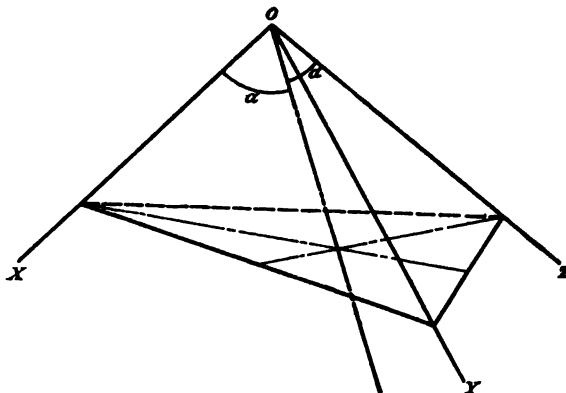

FIG. 16.

*Point-group*  $C_3$ .—

Operations of symmetry:

$$1, \quad A\left(\frac{2\pi}{3}\right), \quad A\left(\frac{4\pi}{3}\right).$$

Coordinates of equivalent points:

$$\text{I. } xyz; \quad zxy; \quad yzx.$$

$$\text{II. } xyz; \quad y-x, \bar{x}, z; \quad \bar{y}, x-y, z.*$$

*Point-group*  $C_3$ .—

Operations of symmetry:

$$C_3 = \{C_3, I\}.$$

\* A reference to figure 17 will show the source of these coordinate values.

Coordinates of equivalent positions:

- I.  $xyz$ ;  $zxy$ ;  $yzx$ ;  $\bar{x}\bar{y}\bar{z}$ ;  $\bar{z}\bar{x}\bar{y}$ ;  $\bar{y}\bar{z}\bar{x}$ .  
 II.  $xyz$ ;  $y-x, \bar{x}, z$ ;  $\bar{y}, x-y, z$ ;  $\bar{x}\bar{y}\bar{z}$ ;  $x-y, x, \bar{z}$ ;  $y, y-x, \bar{z}$ .

Point-group  $C_3^v$ .

Operations of symmetry:  $C_3^v = \{C_3, S_v\}$ .

This vertical reflecting plane can have two possible positions, one containing both the X- and the Z-axes (hexagonal axes II), the other containing the Z-axis and a line in the XY-plane which makes an angle of  $30^\circ$  with the X-axis (see figure 26). The reflection in a plane occupying the first of these two positions will be designated as  $S_a$ , the reflection in the other plane by  $S_s$ .

Coordinates of equivalent points:

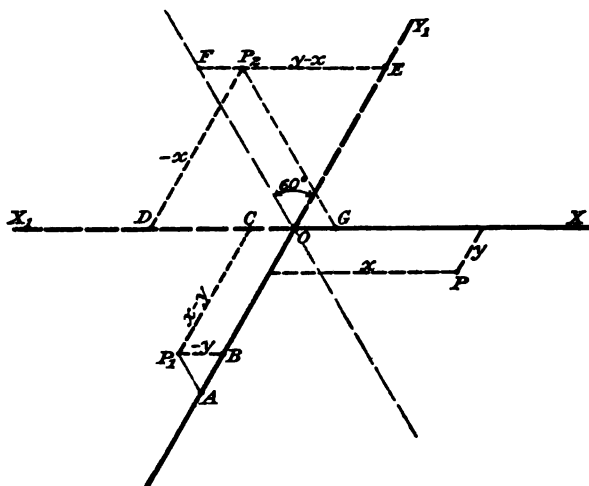

FIG. 17.

I.

- $xyz$ ;  $zxy$ ;  $yzx$ ;  $yxz$ ;  $xzy$ ;  $zyx$ .

II.

When  $C_3^v = \{C_3, S_a\}$ :

- $xyz$ ;  $y-x, \bar{x}, z$ ;  $\bar{y}, x-y, z$ ;  $x-y, \bar{y}, z$ ;  $yxz$ ;  $\bar{x}, y-x, z$ .

When  $C_3^v = \{C_3, S_s\}$ :

- $xyz$ ;  $y-x, \bar{x}, z$ ;  $\bar{y}, x-y, z$ ;  $y-x, y, z$ ;  $\bar{y}\bar{x}\bar{z}$ ;  $x, x-y, z$ .

Point-group  $D_3$ .—

Operations of symmetry:  $D_3 = \{C_3, U\}$ .

The two-fold axis of rotation may lie either in the X-axis or in a line in the XY-plane which makes an angle of  $30^\circ$  with the X-axis. A rotation about the first-named axis will be called  $U_a$ , about the second,  $U_s$ . There may thus be two different sets of coordinates of equivalent points for the point-group  $D_3$  corresponding to the two sets already defined for  $C_3^v$ .



Coordinates of equivalent points:

I.

$xyz; \quad zxy; \quad yzx; \quad \bar{y}\bar{x}\bar{z}; \quad \bar{x}\bar{z}\bar{y}; \quad \bar{z}\bar{y}\bar{x}.$

II.

When  $D_3 = \{C_3, U_3\}$ :

$xyz; \quad y-x, \bar{x}, z; \quad \bar{y}, x-y, z; \quad x-y, \bar{y}, \bar{z}; \quad yx\bar{z}; \quad \bar{x}, y-x, \bar{z}.$

When  $D_3 = \{C_3, U_3\}$ :

$xyz; \quad y-x, \bar{x}, z; \quad \bar{y}, x-y, z; \quad y-x, y, \bar{z}; \quad \bar{y}\bar{x}\bar{z}; \quad x, x-y, \bar{z}.$

*Point-group*  $D_3^d$ .—It can be shown that this point-group arises from the combination of  $D_3$  with an inversion. Just as there are two ways of expressing  $D_3$  in terms of hexagonal axes of reference (depending upon the position of the two-fold axis) so there must be two ways of expressing  $D_3^d$ .

Operations of symmetry:

$$D_3^d = \{D_3, S_6\} = \{D_3, I\}.$$

Coordinates of equivalent points:

I.

$xyz; \quad zxy; \quad yzx; \quad \bar{y}\bar{x}\bar{z}; \quad \bar{x}\bar{z}\bar{y}; \quad \bar{z}\bar{y}\bar{x};$   
 $\bar{x}\bar{y}\bar{z}; \quad \bar{z}\bar{x}\bar{y}; \quad \bar{y}\bar{z}\bar{x}; \quad yxz; \quad xzy; \quad zyx.$

II.

When the operation of the two-fold axis is  $U_2$ :

$xyz; \quad y-x, \bar{x}, z; \quad \bar{y}, x-y, z; \quad x-y, \bar{y}, \bar{z}; \quad yx\bar{z}; \quad \bar{x}, y-x, \bar{z}.$   
 $\bar{x}\bar{y}\bar{z}; \quad x-y, x, \bar{z}; \quad y, y-x, \bar{z}; \quad y-x, y, z; \quad \bar{y}\bar{x}\bar{z}; \quad x, x-y, z.$

When the operation of the two-fold axis is  $U_2$ :

$xyz; \quad y-x, \bar{x}, z; \quad \bar{y}, x-y, z; \quad y-x, y, \bar{z}; \quad \bar{y}\bar{x}\bar{z}; \quad x, x-y, \bar{z};$   
 $\bar{x}\bar{y}\bar{z}; \quad x-y, x, \bar{z}; \quad y, y-x, \bar{z}; \quad x-y, \bar{y}, z; \quad yxz; \quad \bar{x}, y-x, z.$

#### HEXAGONAL DIVISION

The point-groups of this division of the hexagonal system will be expressed only in terms of the hexagonal axes.

*Point-group*  $C_3^h$ .—

Operations of symmetry:

$$C_3^h = \{C_3, S_6\}.$$

Coordinates of equivalent points:

$xyz; \quad y-x, \bar{x}, z; \quad \bar{y}, x-y, z; \quad xy\bar{z}; \quad y-x, \bar{x}, \bar{z}; \quad \bar{y}, x-y, \bar{z}.$

*Point-group*  $D_3^h$ .—

Operations of symmetry:

$$D_3^h = \{D_3, S_6\}.$$

Just as there are two ways of expressing  $D_3$ , so there will be two ways of stating  $D_3^h$ .

Coordinates of equivalent points:

When the two-fold axis has the position of the X-axis ( $U_3$ ):

$$\begin{array}{llllll} xyz; & y-x, \bar{x}, z; & \bar{y}, x-y, z; & x-y, \bar{y}, \bar{z}; & yx\bar{z}; & \bar{x}, y-x, \bar{z}; \\ xy\bar{z}; & y-x, \bar{x}, \bar{z}; & \bar{y}, x-y, \bar{z}; & x-y, \bar{y}, z; & yxz; & \bar{x}, y-x, z. \end{array}$$

When the two-fold axis makes an angle of  $30^\circ$  with the X-axis ( $U_3$ ):

$$\begin{array}{llllll} xyz; & y-x, \bar{x}, z; & \bar{y}, x-y, z; & y-x, y, \bar{z}; & \bar{y}\bar{x}\bar{z}; & x, x-y, \bar{z}; \\ xy\bar{z}; & y-x, \bar{x}, \bar{z}; & \bar{y}, x-y, \bar{z}; & y-x, y, z; & \bar{y}\bar{x}z; & x, x-y, z. \end{array}$$

*Point-group  $C_6$ .*—

The operations of this group can be written as those arising from the operation of a  $60^\circ$  axis of symmetry. Taken thus the operations of  $C_6$  are:

Operations of symmetry:

$$1, \quad A\left(\frac{\pi}{3}\right), \quad A\left(\frac{2\pi}{3}\right), \quad A(\pi), \quad A\left(\frac{4\pi}{3}\right), \quad A\left(\frac{5\pi}{3}\right).$$

Coordinates of equivalent points:

$$xyz; \quad y, y-x, z; \quad y-x, \bar{x}, z; \quad \bar{x}\bar{y}z; \quad \bar{y}, x-y, z; \quad x-y, x, z;$$

*Point-group  $C_6^h$ .*—

Operations of symmetry:

$$C_6^h = \{C_6, S_6\}.$$

Coordinates of equivalent points:

$$\begin{array}{llllll} xyz; & y, y-x, z; & y-x, \bar{x}, z; & \bar{x}\bar{y}z; & \bar{y}, x-y, z; & x-y, x, z; \\ xy\bar{z}; & y, y-x, \bar{z}; & y-x, \bar{x}, \bar{z}; & \bar{x}\bar{y}\bar{z}; & \bar{y}, x-y, \bar{z}; & x-y, x, \bar{z}. \end{array}$$

*Point-group  $C_6^v$ .*—

Operations of symmetry:

$$C_6^v = \{C_6, S_6\}.*$$

Coordinates of equivalent points:

$$\begin{array}{llllll} xyz; & y, y-x, z; & y-x, \bar{x}, z; & \bar{x}\bar{y}z; & \bar{y}, x-y, z; & x-y, x, z; \\ \bar{x}, y-x, z; & y-x, y, z; & yxz; & x, x-y, z; & x-y, \bar{y}, z; & \bar{y}\bar{x}z. \end{array}$$

*Point-group  $D_6$ .*—

Operations of symmetry:

$$D_6 = \{C_6, U\}.$$

U is a rotation of  $180^\circ$  about axes in the XY-plane, one of which coincides with the X-axis.

Coordinates of equivalent points:

$$\begin{array}{llllll} xyz; & y, y-x, z; & y-x, \bar{x}, z; & \bar{x}\bar{y}z; & \bar{y}, x-y, z; & x-y, x, z; \\ \bar{x}, y-x, \bar{z}; & y-x, y, \bar{z}; & yxz; & x, x-y, \bar{z}; & x-y, \bar{y}, \bar{z}; & \bar{y}\bar{x}\bar{z}. \end{array}$$

\* This group is of course equally the result of operating upon  $C_6^v$  by a two-fold axis coincident with the Z-axis. That is,

$$C_6^v = \{C_6, U_1\}.$$

*Point-group*  $D_6^h$ .—

Operations of symmetry:

$$D_6^h = \{D_6, S_6\} = \{D_6, I\}.$$

Coordinates of equivalent points.

$$\begin{array}{llll} xyz; & y, y-x, z; & y-x, \bar{x}, z; & \bar{x}\bar{y}z; & \bar{y}, x-y, z; & x-y, x, z; \\ \bar{x}, y-x, \bar{z}; & y-x, y, \bar{z}; & yx\bar{z}; & x, x-y, \bar{z}; & x-y, \bar{y}, \bar{z}; & \bar{y}\bar{x}\bar{z}. \\ \bar{x}\bar{y}\bar{z}; & \bar{y}, x-y, \bar{z}; & x-y, x, \bar{z}; & xy\bar{z}; & y, y-x, \bar{z}; & y-x, \bar{x}, \bar{z}; \\ x, x-y, z; & x-y, \bar{y}, z; & \bar{y}\bar{x}z; & \bar{x}, y-x, z; & y-x, y, z; & \bar{y}xz. \end{array}$$

### SPACE LATTICES.

A series of parallel planes such that the distance between any two consecutive planes of the series is constant is called a set of planes.

The sum total of the points of intersection of any three sets of planes is called a regular space lattice.

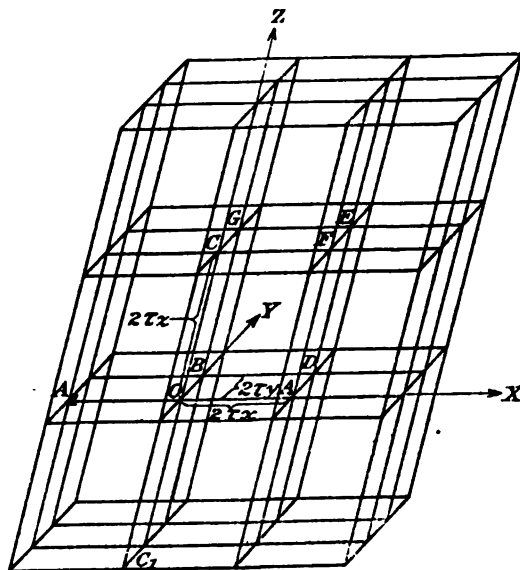

FIG. 18. A symmetrical lattice. The intersection points of this figure are points of the lattice.

If some point of a lattice (O of figure 18) is taken as the origin of coordinates, the neighboring points of the lattice are given by the translations  $\pm 2\tau_x$ ,  $\pm 2\tau_y$ ,  $\pm 2\tau_z$  along the X, Y and Z axes; and in general any point of the lattice is given by the composite translation

$$\tau_1 = \pm 2m\tau_x \pm 2n\tau_y \pm 2p\tau_z,$$

where m, n and p are any integers or zero. The three translations,  $2\tau_x$ ,  $2\tau_y$ ,  $2\tau_z$ , giving neighboring points of the lattice, are called the primitive trans-

lations. It is customary to define a lattice by stating its primitive translations with respect to the axes of reference.\* This definition is sufficient since the primitive translations of a lattice can be considered as those translations which will yield all of the points of the lattice by their continued application, first to a point of the lattice chosen as origin, and to the new points continually derived from this and succeeding applications.

It can be shown that but fourteen symmetrical lattices are possible; each of them has the complete symmetry of one of the seven systems of crystallographic symmetry (counting the rhombohedral division of the hexagonal system as a separate system).

The primitive translations of these 14 space-lattices, identical with the lattices of Bravais, are as follows. The axes of reference are the same as those used for the point-groups of corresponding symmetry.

<i>Symbol.</i>	<i>Primitive translations.</i>
<i>Triclinic system.</i>	
1. $\Gamma_{\text{tr}}$	$2\tau_x; 2\tau_y; 2\tau_z.$
<i>Monoclinic system.</i>	
2. $\Gamma_{\text{m}}$	$2\tau_x; 2\tau_y; 2\tau_z.$
3. $\Gamma_{\text{m}}'$	$2\tau_x; \tau_y, \tau_z; \tau_y, -\tau_z. \dagger$
<i>Orthorhombic system.</i>	
4. $\Gamma_{\text{o}}$	$2\tau_x; 2\tau_y; 2\tau_z.$
5a. $\Gamma_{\text{o}}'(\text{a})$	$\tau_x, \tau_y; \tau_x, -\tau_y; 2\tau_z.$
b. $\Gamma_{\text{o}}'(\text{b})$	$2\tau_x; \tau_y, \tau_z; \tau_y, -\tau_z.$
6. $\Gamma_{\text{o}}''$	$\tau_y, \tau_z; \tau_z, \tau_x; \tau_x, \tau_y.$
7. $\Gamma_{\text{o}}'''$	$2\tau_x; 2\tau_y; 2\tau_z; \tau_x, \tau_y, \tau_z.$
<i>Tetragonal system.</i>	
8a. $\Gamma_{\text{t}}(\text{a})$	$2\tau_x; 2\tau_y; 2\tau_z.$
b. $\Gamma_{\text{t}}(\text{b})$	$\tau_x, \tau_y; \tau_x, -\tau_y; 2\tau_z.$
9a. $\Gamma_{\text{t}}'(\text{a})$	$\tau_y, \tau_z; \tau_z, \tau_x; \tau_x, \tau_y.$
b. $\Gamma_{\text{t}}'(\text{b})$	$2\tau_x; 2\tau_y; 2\tau_z; \tau_x, \tau_y, \tau_z.$
<i>Cubic system.</i>	
10. $\Gamma_{\text{c}}$	$2\tau_x; 2\tau_y; 2\tau_z.$
11. $\Gamma_{\text{c}}'$	$\tau_y, \tau_z; \tau_z, \tau_x; \tau_x, \tau_y.$
12. $\Gamma_{\text{c}}''$	$2\tau_x; 2\tau_y; 2\tau_z; \tau_x, \tau_y, \tau_z.$
<i>Hexagonal system.</i>	
13. $\Gamma_{\text{rh}}$	$2\tau_x; 2\tau_y; 2\tau_z. \text{ (Rhombohedral Axes)}$
14. $\Gamma_{\text{h}}$	$2\tau_x; 2\tau_y; 2\tau_z. \text{ (Hexagonal Axes)}$

\* Different groups of primitive translations for a single lattice are possible by taking the unit directions differently. We shall have use for the primitive translations just defined and for no others.

† By  $\tau_y, \tau_z$  is meant a translation  $\tau_y$  along the Y-axis followed by one of length  $\tau_z$  along the Z-axis. The translation  $\tau_y, -\tau_z$  is similar except that  $\tau_z$  is here taken in the  $-z$  direction. These are written by Schoenflies as  $\tau_y + \tau_z$  and  $\tau_y - \tau_z$  respectively.

Lattices 13 and 14 belong to the rhombohedral division; lattice 14 has the complete symmetry of the hexagonal division of the hexagonal system.

Lattices 2, 4, 8a, 10, 13 and 14 are all special cases of lattice 1, in which the lengths of the units along the axes or the angles between the axes have particular values. The lattices having the symmetry of the tetragonal and of the cubic system can be looked upon as special cases of the orthorhombic space lattices; in this process of specialization, for lattices of tetragonal symmetry, if the axes are taken after the manner of lattice 4, 8a is obtained, if according to 5, 8b results. The two forms of 8 are, however, identical. In a similar fashion 9a and 9b arise from 6 and 7.

### SPACE-GROUPS.

In giving analytical representations to each of the 32 point-groups the different ways have been expressed in which points can group themselves about a central position so that the aggregate of points will by their arrangement exhibit crystallographic symmetry. We are not, however, primarily

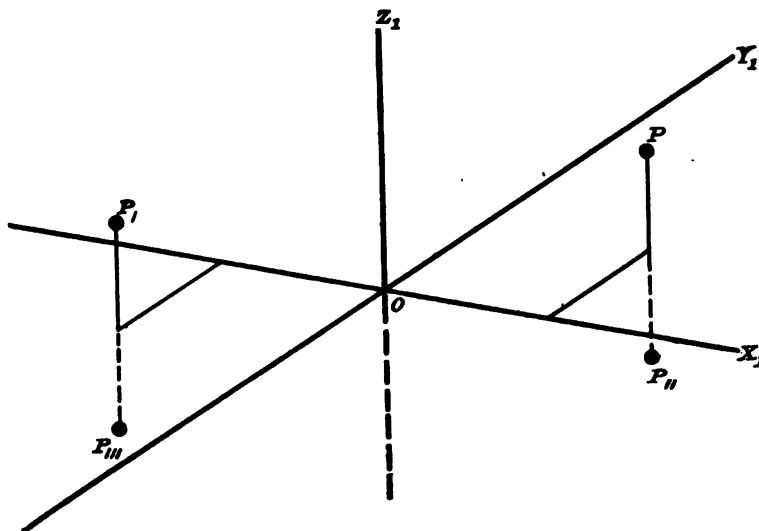

FIG. 19. The point-group  $C_{2h}$ . The points  $P, P', P'', P'''$  are the four equivalent points of this point-group.

interested in such an aggregate of points about a single position in space but rather in the indefinite extension in all directions of such a symmetrical grouping of points. In order to accomplish this, it is necessary to distribute point-groups (or perhaps other suitably symmetrical groupings of points), properly oriented according to some regular pattern which repeats itself indefinitely in all directions. Such a regular pattern must be one of the 14 space lattices. The indefinitely extended symmetrical arrangement of points all equivalent to one another, which is obtained by placing such groups of

equivalent points with their centers at the points of one of the regular space lattices, is a *space-group*.\*

For the sake of illustration the very simple space-group which is obtained by placing the point-group  $C_2^h$ , the holohedry of the monoclinic system, (figure 19) at the points of the monoclinic space lattice  $\Gamma_m$  will be considered.† A portion from this space-group is shown in figure 20. The four equivalent

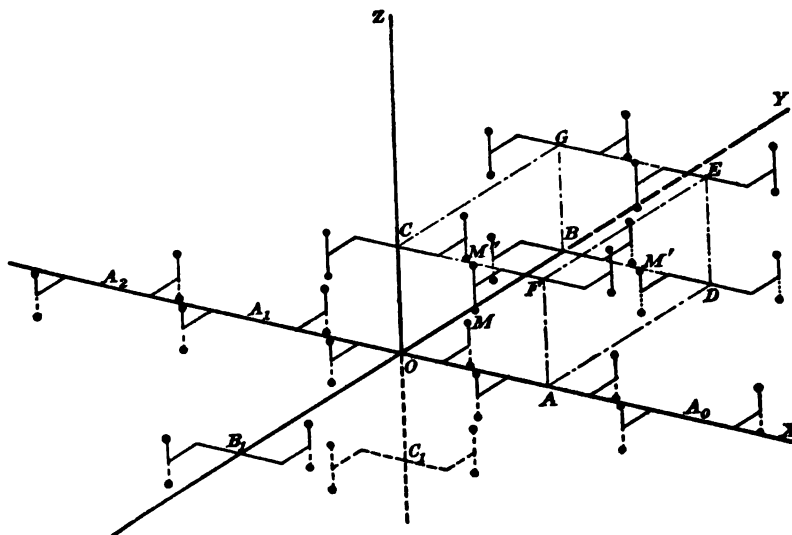

FIG. 20. A portion from the monoclinic space-group  $C_{2h}^1$ .

points  $P$ ,  $P_I$ ,  $P_{II}$  and  $P_{III}$  (and the two-fold axis of symmetry and the plane normal to it) of  $C_2^h$  repeat themselves about each of the points  $O$ ,  $A$ ,  $B$ , . . . . . of the first monoclinic lattice  $\Gamma_m$ . Taking  $O$  as the origin, then the coordinates of the points of the group about  $A$ , the point of the lattice obtained by the primitive translation  $2\tau_x$ , are

$$x+2\tau_x, y, z; 2\tau_x-x, \bar{y}, z; 2\tau_x-x, \bar{y}, \bar{z}; x+2\tau_x, y, \bar{z}.$$

In a similar way the coordinates of the equivalent points about the other neighboring points of the lattice and in general about any point of the lattice

\* The view which one takes of a space-group will depend largely upon his interests. For instance, the crystallographer will in all probability consider a point-group as a particular aggregation of elements of symmetry arranged in some definite fashion. The space-groups will then, first and above all, describe to him the way in which these elements of symmetry can be distributed throughout a crystal. On the other hand, the physicist or chemist who is accustomed to think of a crystal essentially as an orderly arrangement of atoms or molecular groupings of atoms will probably incline to the more analytical view of point-groups and space-groups as aggregates of equivalent points which are potential positions for the atoms in crystals. Because we are interested here in discussing only those phases of the theory of space-groups which are of immediate use to the physical study of the structures of crystals, the characteristics of symmetry possessed by the various space-groups will receive only such treatment as is required for the building up of an analytical expression of the results of the theory.

† Figure 18 will illustrate  $\Gamma_m$  if  $X$  and  $Y$  have any unit lengths and make any angle with one another, and if  $Z$  is normal to the plane  $XY$ .

are given by one of the following sets which, taken together, completely define this space-group:

$$\begin{array}{lll} x \pm 2m\tau_x, & y \pm 2n\tau_y, & z \pm 2p\tau_z; \\ \pm 2m\tau_x - x, & \pm 2n\tau_y - y, & z \pm 2p\tau_z; \\ \pm 2m\tau_x - x, & \pm 2n\tau_y - y, & \pm 2p\tau_z - z; \\ x \pm 2m\tau_x, & y \pm 2n\tau_y, & \pm 2p\tau_z - z; \end{array}$$

where, as before,  $m$ ,  $n$  and  $p$  can be any integers or zero.

Some of the space-groups are obtained by thus placing point-groups at the points of the lattice of corresponding symmetry; the rest of the 230 typical ways of arranging points so that the assemblage will exhibit crystallographic symmetry may be obtained by placing, at the points of these lattices, groups of points analogous to the point-groups, and derived from them, of such a nature that the symmetry of the aggregate is that of one of the point-groups themselves.

It is obvious that a space-group is completely defined (analytically) when the coordinates of the equivalent points ranged about one point of the lattice (the points of a point-group or of a "modified point-group") and the primitive translations of the lattice are given; for, as we have just seen in the case of the monoclinic space-group, with this information it is always possible to reconstruct the space-group.

#### AN OUTLINE OF THE DERIVATION OF THE SPACE-GROUPS.

The nature of each of the space-groups will be apparent from the following tabular outline. Under each class of symmetry a brief discussion of the development of the space-groups exhibiting its symmetry will be given. This will be followed by a statement under three headings of (1) the symbol of the space-group, (2) an abbreviated indication of its particular derivation, and (3) the fundamental lattice underlying it.

##### TRICLINIC SYSTEM.

###### *Hemihedry.*—

The single space-group of this class is obtained by placing the single equivalent point of the point-group  $C_1$  at the points of the lattice  $\Gamma_{\text{tr}}$ .

$$1. \{C_1^1 = C_1, \Gamma_{\text{tr}}\}.^* \quad \Gamma_{\text{tr}}$$

###### *Holohedry.*—

The single space-group having this symmetry is obtained by placing the equivalent points of  $C_1$  at the points of the lattice  $\Gamma_{\text{tr}}$ .

$$2. C_1^1 = \{C_1, \Gamma_{\text{tr}}\}. \quad \Gamma_{\text{tr}}$$

---

\* The space-group symbol is a simple adaptation of the symbols used for the point-groups. The letters to be found in exponent position in the symbols for point-groups are reduced to the subscript position. The different space-groups isomorphous with a particular point-group are distinguished by numbers in the exponent position. Thus  $C_{2h}^5$  is the fifth space-group (isomorphous with the point-group  $C_2^h$ ) that is defined.

## MONOCLINIC SYSTEM.

*Hemihedry.*—

The space-groups having this symmetry can be developed by combining the space-group  $C_1^1$  when it has the specialized form of either  $\Gamma_m$  or  $\Gamma_m'$ , with a gliding reflection in a plane which is taken as that of the X- and Y-axes.\*

- |   |             |
|---|-------------|
| 3. $C_2^1 = \{\Gamma_m, S_h\}$ .        | $\Gamma_m$  |
| 4. $C_2^2 = \{\Gamma_m, S_h(\tau)\}$ .  | $\Gamma_m$  |
| 5. $C_2^3 = \{\Gamma_m', S_h\}$ .       | $\Gamma_m'$ |
| 6. $C_2^4 = \{\Gamma_m', S_h(\tau)\}$ . | $\Gamma_m'$ |

*Hemimorphic hemihedry.*—

Since the point-group  $C_2$  is obtained by combining  $C_1$  with a two-fold axis, the space-groups isomorphous with  $C_2$  can be obtained by combining the lattices  $\Gamma_m$  and  $\Gamma_m'$  with screw axes of symmetry. The translation components of these screw-axes are either zero or half a primitive translation in the direction of the Z-axis.

- |  |             |
|--|-------------|
| 7. $C_2^1 = \{\Gamma_m, A(\pi)\}$ .                                  | $\Gamma_m$  |
| 8. $C_2^2 = \{\Gamma_m, A(\pi, \tau_z)\}$ .                          | $\Gamma_m$  |
| 9. $C_2^3 = \{\Gamma_m', A(\pi)\} = \{\Gamma_m', A(\pi, \tau_z)\}$ . | $\Gamma_m'$ |

*Holohedry.*—

The space-groups isomorphous with  $C_2^h$  can be obtained by multiplying (=combining) space-groups isomorphous with  $C_2$  with the operation of a glide plane of symmetry. Since a rotation of  $180^\circ$  combined with a reflection in a plane at right angles to the axis of rotation is equivalent to an inversion, these space-groups result also from multiplying the groups isomorphous with  $C_2$  by an inversion.

- |   |             |
|---|-------------|
| 10. $C_{2h}^1 = \{C_2^1, S_h\}$ .       | $\Gamma_m$  |
| 11. $C_{2h}^2 = \{C_2^2, S_h\}$ .       | $\Gamma_m'$ |
| 12. $C_{2h}^3 = \{C_2^3, S_h\}$ .       | $\Gamma_m'$ |
| 13. $C_{2h}^4 = \{C_2^1, S_h(\tau)\}$ . | $\Gamma_m$  |
| 14. $C_{2h}^5 = \{C_2^2, S_h(\tau)\}$ . | $\Gamma_m$  |
| 15. $C_{2h}^6 = \{C_2^3, S_h(\tau)\}$ . | $\Gamma_m'$ |

## ORTHORHOMBIC SYSTEM.

*Hemimorphic hemihedry.*—

The intersections with the XY-plane of the axes of space-groups  $C_2^m$  (the space-groups having the symmetry of  $C_2$ ) when the angle between the axes has the special value of  $90^\circ$ , is given by the points A, B, C, D,  $A_1 \dots$  of figure 21. The space-groups isomorphous with  $C_2^v$  can be developed by

\* A glide plane the translation component of which is zero is of course a simple reflecting plane.  $\tau$ , a primitive translation in the XY-plane, may then be chosen as either  $\tau_x$  or  $\tau_y$ .



multiplying groups isomorphous with  $C_2$  by a vertical glide plane of symmetry, that is, one parallel to or containing the  $Z$ -axis. The various possible positions of the intersections of these planes with the  $XY$ -plane are shown by  $\sigma$ ,  $\sigma_m$ , etc. of figure 21a and  $\sigma_d$ ,  $\sigma_d'$ , etc. of figure 21b.

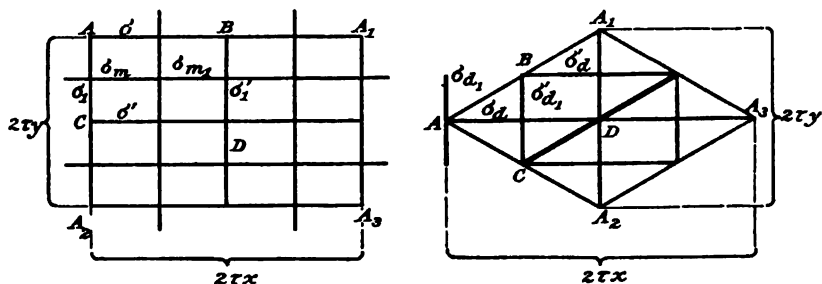

FIG. 21.

- |     |  |                |
|-----|--|----------------|
| 16. | $C_{2v}^1 = \{C_2^1, S\} = \{C_2^1, S_1\}$ .                   | $\Gamma_0$     |
| 17. | $C_{2v}^2 = \{C_2^2, S\} = \{C_2^2, S_1(\tau_x)\}$ .           | $\Gamma_0$     |
| 18. | $C_{2v}^3 = \{C_2^1, S(\tau_x)\}$ .                            | $\Gamma_0$     |
| 19. | $C_{2v}^4 = \{C_2^1, S(\tau_x)\} = \{C_2^1, S_{m_1}\}$ .       | $\Gamma_0$     |
| 20. | $C_{2v}^5 = \{C_2^2, S(\tau_x)\}$ .                            | $\Gamma_0$     |
| 21. | $C_{2v}^6 = \{C_2^1, S(\tau_x + \tau_y)\}$ .                   | $\Gamma_0$     |
| 22. | $C_{2v}^7 = \{C_2^2, S(\tau_x + \tau_y)\}$ .                   | $\Gamma_0$     |
| 23. | $C_{2v}^8 = \{C_2^1, S_m(\tau_x)\}$ .                          | $\Gamma_0$     |
| 24. | $C_{2v}^9 = \{C_2^2, S_m(\tau_x)\}$ .                          | $\Gamma_0$     |
| 25. | $C_{2v}^{10} = \{C_2^1, S_m(\tau_x + \tau_y)\}$ .              | $\Gamma_0$     |
| 26. | $C_{2v}^{11} = \{C_2^1, S_d\} = \{C_2^1, S_{d_1}\}$ .          | $\Gamma_0'(a)$ |
| 27. | $C_{2v}^{12} = \{C_2^2, S_d\}$ .                               | $\Gamma_0'(a)$ |
| 28. | $C_{2v}^{13} = \{C_2^1, S_d(\tau_x)\}$ .                       | $\Gamma_0'(a)$ |
| 29. | $C_{2v}^{14} = \{C_2^2, S\}$ .                                 | $\Gamma_0'(b)$ |
| 30. | $C_{2v}^{15} = \{C_2^2, S(\tau_x)\}$ .                         | $\Gamma_0'(b)$ |
| 31. | $C_{2v}^{16} = \{C_2^2, S(\tau_x)\}$ .                         | $\Gamma_0'(b)$ |
| 32. | $C_{2v}^{17} = \{C_2^2, S(\tau_x + \tau_y)\}$ .                | $\Gamma_0'(b)$ |
| 33. | $C_{2v}^{18} = \{C_2^2, S\}$ .                                 | $\Gamma_0''$   |
| 34. | $C_{2v}^{19} = \{C_2^2, S_m[\frac{1}{2}(\tau_x + \tau_y)]\}$ . | $\Gamma_0''$   |
| 35. | $C_{2v}^{20} = \{C_2^2, S_d\}$ .                               | $\Gamma_0'''$  |
| 36. | $C_{2v}^{21} = \{C_2^2, S_d(\tau_x)\}$ .                       | $\Gamma_0'''$  |
| 37. | $C_{2v}^{22} = \{C_2^2, S_d(\tau_x)\}$ .                       | $\Gamma_0'''$  |

*Enantiomorphic hemihedry.—*

*Definition.*—If a certain portion of the operations of a group when taken alone themselves form a group, they define a sub-group.

The space-groups isomorphous with the point group  $V$  are best described by giving the sub-groups whose axes are parallel to the  $X$ ,  $Y$ - and  $Z$ - axes of the lattice (and of the coordinates).

- 38.  $V^1 = \{C_2^1, C_2^1, C_2^1\}. \Gamma_0$
- 39.  $V^2 = \{C_2^1, C_2^1, C_2^2\}. \Gamma_0$
- 40.  $V^3 = \{C_2^2, C_2^2, C_2^1\}. \Gamma_0$
- 41.  $V^4 = \{C_2^2, C_2^2, C_2^2\}. \Gamma_0$
- 42.  $V^5 = \{C_2^3, C_2^3, C_2^2\}. \Gamma_0'(a)$
- 43.  $V^6 = \{C_2^3, C_2^3, C_2^1\}. \Gamma_0'(a)$
- 44.  $V^7 = \{C_2^3, C_2^3, C_2^3\}. \Gamma_0''$
- 45.  $V^8 = \{C_2^3, C_2^3, C_2^3\}. \Gamma_0'''$
- 46.  $V^9 = \{C_2^3, C_2^3, C_2^3\}. \Gamma_0'''$

*Holohedry.*—

The space-groups isomorphous with  $V^h$  can be obtained by combining groups isomorphous with  $V$  with a horizontal gliding reflection. It is more simple, however, to consider them as developed by combining certain groups  $V^m$  with inversions. The locations of these points of inversion will be clear from a reference to figure 22.

- 47.  $V_h^1 = \{V^1, I\}. \Gamma_0$
- 48.  $V_h^2 = \{V^1, I_m\}. \Gamma_0$
- 49.  $V_h^3 = \{V^1, I_w\}. \Gamma_0$
- 50.  $V_h^4 = \{V^1, I_g\}. \Gamma_0$
- 51.  $V_h^5 = \{V^2, I\}. \Gamma_0$
- 52.  $V_h^6 = \{V^2, I_m\}. \Gamma_0$
- 53.  $V_h^7 = \{V^2, I_u\}. \Gamma_0$
- 54.  $V_h^8 = \{V^2, I_k\}. \Gamma_0$
- 55.  $V_h^9 = \{V^3, I\}. \Gamma_0$
- 56.  $V_h^{10} = \{V^3, I_m\}. \Gamma_0$
- 57.  $V_h^{11} = \{V^3, I_k\}. \Gamma_0$
- 58.  $V_h^{12} = \{V^3, I_w\}. \Gamma_0$
- 59.  $V_h^{13} = \{V^3, I_g\}. \Gamma_0$
- 60.  $V_h^{14} = \{V^3, I_f\}. \Gamma_0$
- 61.  $V_h^{15} = \{V^4, I\}. \Gamma_0$
- 62.  $V_h^{16} = \{V^4, I_g\}. \Gamma_0$
- 63.  $V_h^{17} = \{V^5, I\}. \Gamma_0'(a)$
- 64.  $V_h^{18} = \{V^5, I_u\}. \Gamma_0'(a)$
- 65.  $V_h^{19} = \{V^6, I\}. \Gamma_0'(a)$
- 66.  $V_h^{20} = \{V^6, I_m\}. \Gamma_0'(a)$
- 67.  $V_h^{21} = \{V^6, I_u\}. \Gamma_0'(a)$
- 68.  $V_h^{22} = \{V^6, I_f\}. \Gamma_0'(a)$
- 69.  $V_h^{23} = \{V^7, I\}. \Gamma_0''$
- 70.  $C_h^{24} = \{V^7, I_m\}. \Gamma_0''$
- 71.  $V_h^{25} = \{V^8, I\}. \Gamma_0'''$
- 72.  $V_h^{26} = \{V^8, I_w\}. \Gamma_0'''$
- 73.  $V_h^{27} = \{V^9, I\}. \Gamma_0'''$
- 74.  $V_h^{28} = \{V^9, I_g\}. \Gamma_0'''$

\* These two last space-groups differ in the manner of distribution of their axes. For the former the axis of rotation lies in the line AD, for the latter in the line BC of Figure 21.



*Tetartohedry.*—

The space-groups  $C_4^m$  can be derived by arranging screw-axes of symmetry according to the two tetragonal lattices.

$$\begin{aligned}
 89. \quad C_4^1 &= \left\{ A\left(\frac{\pi}{2}\right), \Gamma_t \right\} & \Gamma_t \\
 90. \quad C_4^2 &= \left\{ A\left(\frac{\pi}{2}, \frac{\tau_s}{2}\right), \Gamma_t \right\}. & \Gamma_t \\
 91. \quad C_4^3 &= \left\{ A\left(\frac{\pi}{2}, \tau_s\right), \Gamma_t \right\}. & \Gamma_t \\
 92. \quad C_4^4 &= \left\{ A\left(\frac{\pi}{2}, \frac{3\tau_s}{2}\right), \Gamma_t \right\}. & \Gamma_t \\
 93. \quad C_4^5 &= \left\{ A\left(\frac{\pi}{2}\right), \Gamma_t' \right\}. & \Gamma_t' \\
 94. \quad C_4^6 &= \left\{ A\left(\frac{\pi}{2}, \frac{\tau_s}{2}\right), \Gamma_t' \right\} & \Gamma_t'
 \end{aligned}$$

*Paramorphic hemihedry.*—

The groups  $C_{4h}^m$  are most readily obtained by inverting groups isomorphous with  $C_4$  either through a point lying in a four-fold axis or midway of a line joining two four-fold axes. This second inversion will be represented by  $I_1$ .

$$\begin{aligned}
 95. \quad C_{4h}^1 &= \{C_4^1, I\}. & \Gamma_t \\
 96. \quad C_{4h}^2 &= \{C_4^2, I\}. & \Gamma_t \\
 97. \quad C_{4h}^3 &= \{C_4^3, I_1\}. & \Gamma_t \\
 98. \quad C_{4h}^4 &= \{C_4^4, I_1\}. & \Gamma_t \\
 99. \quad C_{4h}^5 &= \{C_4^5, I\}. & \Gamma_t' \\
 100. \quad C_{4h}^6 &= \{C_4^6, I_1\}. & \Gamma_t'
 \end{aligned}$$

*Hemimorphic hemihedry.*—

The groups  $C_{4v}^m$  are obtained by multiplying groups  $C_4^m$  by vertical gliding reflections. The positions of these reflecting planes are shown in figure 23.

$$\begin{aligned}
 101. \quad C_{4v}^1 &= \{C_4^1, S_s\}. & \Gamma_t \\
 102. \quad C_{4v}^2 &= \{C_4^1, S_o\}. & \Gamma_t \\
 103. \quad C_{4v}^3 &= \{C_4^3, S_s\}. & \Gamma_t \\
 104. \quad C_{4v}^4 &= \{C_4^3, S_o\}. & \Gamma_t \\
 105. \quad C_{4v}^5 &= \{C_4^1, S_s(\tau_s)\}. & \Gamma_t \\
 106. \quad C_{4v}^6 &= \{C_4^1, S_o(\tau_s)\}. & \Gamma_t \\
 107. \quad C_{4v}^7 &= \{C_4^3, S_s(\tau_s)\}. & \Gamma_t \\
 108. \quad C_{4v}^8 &= \{C_4^3, S_o(\tau_s)\}. & \Gamma_t \\
 109. \quad C_{4v}^9 &= \{C_4^5, S_s\}. & \Gamma_t' \\
 110. \quad C_{4v}^{10} &= \{C_4^5, S_s(\tau_s)\}. & \Gamma_t' \\
 111. \quad C_{4v}^{11} &= \{C_4^5, S_o\}. & \Gamma_t' \\
 112. \quad C_{4v}^{12} &= \{C_4^5, S_o(\tau_s)\}. & \Gamma_t'
 \end{aligned}$$

*Enantiomorphic hemihedry.*—

Since the point-group  $D_4$  results from the multiplication of  $C_4$  by a two-fold axis lying in the plane normal to the four-fold axis of  $C_4$ , the groups  $D_m^4$  arise by multiplying certain of the groups  $C_m^4$  by two-fold axes lying in the XY-plane. The positions of these axes are shown in figure 23, if the lines AB and  $C_1C_2$  define the axes  $U_s$  and  $U_o$  respectively.

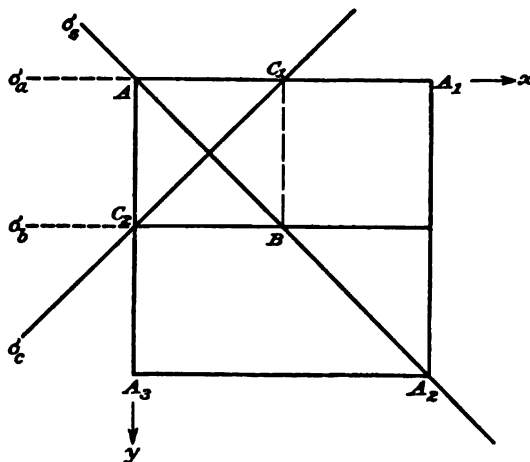

FIG. 23.

- |      |                               |             |
|------|-------------------------------|-------------|
| 113. | $D_4^1 = \{C_4^1, U_s\}$ .    | $\Gamma_t$  |
| 114. | $D_4^2 = \{C_4^1, U_o\}$ .    | $\Gamma_t$  |
| 115. | $D_4^3 = \{C_4^2, U_s\}$ .    | $\Gamma_t$  |
| 116. | $D_4^4 = \{C_4^2, U_o\}$ .    | $\Gamma_t$  |
| 117. | $D_4^5 = \{C_4^3, U_s\}$ .    | $\Gamma_t$  |
| 118. | $D_4^6 = \{C_4^3, U_o\}$ .    | $\Gamma_t$  |
| 119. | $D_4^7 = \{C_4^4, U_s\}$ .    | $\Gamma_t$  |
| 120. | $D_4^8 = \{C_4^4, U_o\}$ .    | $\Gamma_t$  |
| 121. | $D_4^9 = \{C_4^5, U_s\}$ .    | $\Gamma_t'$ |
| 122. | $D_4^{10} = \{C_4^5, U_o\}$ . | $\Gamma_t'$ |

*Holohedry.*—

The space-groups  $D_{4h}^m$  may be derived by combining groups of  $D_m^4$  with an inversion. If the axes striking the XY-plane in A, A<sub>1</sub>, etc. (figure 23) are called *a* and those meeting the plane in points corresponding to B are called *b*, then the points of inversion are located (1) at the intersection of *a* with an axis parallel to  $U_s$ , (2) midway between two such points of intersection, (3) on an axis parallel to  $U_o$ , midway between *a* and *b* or (4) half of the way between *a* and *b* and half way between axes parallel to  $U_s$ . The inversions through these four points will be denoted by I, I', I<sub>1</sub> and I<sub>1</sub>'. These four inversions

are equivalent to inversions  $I$ ,  $I_w$ ,  $I_g$ , and  $I_m$  about the four points A, W, G, and M of figure 22.

- |      |                                     |             |
|------|-------------------------------------|-------------|
| 123. | $D_{4h}^1 = \{D_4^1, I\}$ .         | $\Gamma_t$  |
| 124. | $D_{4h}^2 = \{D_4^1, I_w\}$ .       | $\Gamma_t$  |
| 125. | $D_{4h}^3 = \{D_4^1, I_g\}$ .       | $\Gamma_t$  |
| 126. | $D_{4h}^4 = \{D_4^1, I_m\}$ .       | $\Gamma_t$  |
| 127. | $D_{4h}^5 = \{D_4^2, I\}$ .         | $\Gamma_t$  |
| 128. | $D_{4h}^6 = \{D_4^2, I_w\}$ .       | $\Gamma_t$  |
| 129. | $D_{4h}^7 = \{D_4^2, I_g\}$ .       | $\Gamma_t$  |
| 130. | $D_{4h}^8 = \{D_4^2, I_m\}$ .       | $\Gamma_t$  |
| 131. | $D_{4h}^9 = \{D_4^5, I\}$ .         | $\Gamma_t$  |
| 132. | $D_{4h}^{10} = \{D_4^5, I_w\}$ .    | $\Gamma_t$  |
| 133. | $D_{4h}^{11} = \{D_4^5, I_g\}$ .    | $\Gamma_t$  |
| 134. | $D_{4h}^{12} = \{D_4^5, I_m\}$ .    | $\Gamma_t$  |
| 135. | $D_{4h}^{13} = \{D_4^9, I\}$ .      | $\Gamma_t$  |
| 136. | $D_{4h}^{14} = \{D_4^9, I_w\}$ .    | $\Gamma_t$  |
| 137. | $D_{4h}^{15} = \{D_4^9, I_g\}$ .    | $\Gamma_t$  |
| 138. | $D_{4h}^{16} = \{D_4^9, I_m\}$ .    | $\Gamma_t$  |
| 139. | $D_{4h}^{17} = \{D_4^9, I\}$ .      | $\Gamma_t'$ |
| 140. | $D_{4h}^{18} = \{D_4^9, I_w\}$ .    | $\Gamma_t'$ |
| 141. | $D_{4h}^{19} = \{D_4^{10}, I_g\}$ . | $\Gamma_t'$ |
| 142. | $D_{4h}^{20} = \{D_4^{10}, I_m\}$ . | $\Gamma_t'$ |

## CUBIC SYSTEM.

*Tetartohedry.*—

The space-groups isomorphous with T can be obtained by combining certain groups  $V^m$  with the operation of a three-fold rotation axis. Except in the case of the group derived from  $V^7$ , when it must be  $AA'$ , the position of this three-fold axis can be that of any diagonal of figure 22. This rotation of angle  $\frac{2\pi}{3}$  will be represented by A.

- |      |                      |              |
|------|----------------------|--------------|
| 143. | $T^1 = \{V^1, A\}$ . | $\Gamma_o$   |
| 144. | $T^2 = \{V^7, A\}$ . | $\Gamma_o'$  |
| 145. | $T^3 = \{V^8, A\}$ . | $\Gamma_o''$ |
| 146. | $T^4 = \{V^4, A\}$ . | $\Gamma_o$   |
| 147. | $T^5 = \{V^9, A\}$ . | $\Gamma_o''$ |

*Paramorphic hemihedry.*—

Since the point-group  $T_h$  can be derived from the point-group T by combining it with an inversion (as well as with the operation of a horizontal plane of symmetry), the groups isomorphous with  $T^h$  can be obtained from the groups  $T^m$  by combining them with an inversion. This center of symmetry

lies either at a corner of the cube of figure 22 (A) or at M. These two inversions will be called I and  $I_m$  respectively.

148.  $T_h^1 = \{T^1, I\}$ .  $\Gamma_o$   
 149.  $T_h^2 = \{T^1, I_m\}$ .  $\Gamma_o$   
 150.  $T_h^3 = \{T^2, I\}$ .  $\Gamma_o'$   
 151.  $T_h^4 = \{T^2, I_m\}$ .  $\Gamma_o'$   
 152.  $T_h^5 = \{T^3, I\}$ .  $\Gamma_o''$   
 153.  $T_h^6 = \{T^4, I\}$ .  $\Gamma_o$   
 154.  $T_h^7 = \{T^5, I\}$ .  $\Gamma_o''$

*Hemimorphic hemihedry.*—

The groups isomorphous with  $T^d$  can be derived by combining groups  $T^m$  with a gliding reflection in a diagonal plane. This plane can be taken as WMGA of figure 22.

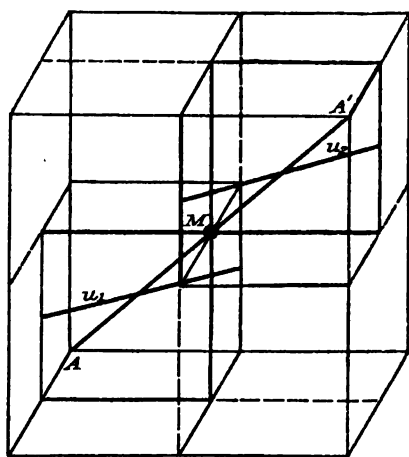

FIG. 24.

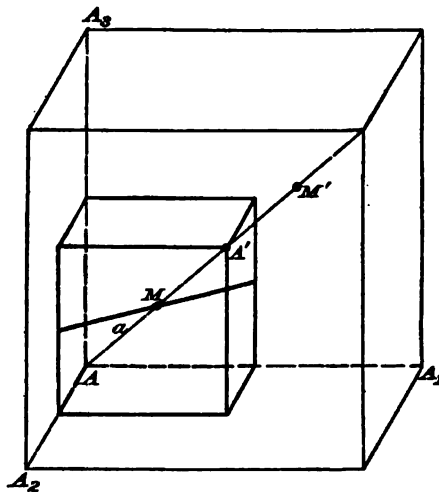

FIG. 25.

155.  $T_d^1 = \{T^1, S_4\}$ .  $\Gamma_o$   
 156.  $T_d^2 = \{T^2, S_4\}$ .  $\Gamma_o'$   
 157.  $T_d^3 = \{T^3, S_4\}$ .  $\Gamma_o''$   
 158.  $T_d^4 = \{T^1, S_4(\tau)\}$ .  $\Gamma_o$   
 159.  $T_d^5 = \{T^2, S_4(\tau)\}$ .  $\Gamma_o'$   
 160.  $T_d^6 = \{T^3, S_4(\tau)\}$ .  $\Gamma_o''$

*Enantiomorphic hemihedry.*—

The groups  $O^m$  result from combining groups  $T^m$  with the operation of a two-fold rotation axis. This axis may be taken parallel to UK of figure 22. If it passes through the point M of figure 22 the rotation will be denoted by  $U_m$ , (2) if it has a parallel position through the point A by U, (3) if it lies in the line bisecting AM (see figure 24) by  $U_1$ , or (4) if it bisects  $MA'$  by  $U_2$ .

161.  $O^1 = \{T^1, U\}$ .  $\Gamma_o$   
 162.  $O^2 = \{T^1, U_m\}$ .  $\Gamma_o$   
 163.  $O^3 = \{T^2, U\}$ .  $\Gamma_o'$   
 164.  $O^4 = \{T^2, U_m\}$ .  $\Gamma_o'$   
 165.  $O^5 = \{T^3, U\}$ .  $\Gamma_o''$   
 166.  $O^6 = \{T^4, U_1\}$ .  $\Gamma_o$   
 167.  $O^7 = \{T^4, U_2\}$ .  $\Gamma_o$   
 168.  $O^8 = \{T^4, U\}$ .  $\Gamma_o''$

*Holohedry.*—

Since the point-group  $O^h$  results from  $O$  by the operation of a center of symmetry, as well as of a horizontal reflecting plane, the groups  $O_h^m$  isomorphous with  $O^h$  can be obtained by combining groups  $O^m$  with an inversion. These centers may be at  $A, A', M$  or  $M'$  of figure 25; the corresponding inversions will be called  $I, I', I_m, I_m'$ .

169.  $O_h^1 = \{O^1, I\}$ .  $\Gamma_o$   
 170.  $O_h^2 = \{O^1, I_m\}$ .  $\Gamma_o$   
 171.  $O_h^3 = \{O^2, I\}$ .  $\Gamma_o$   
 172.  $O_h^4 = \{O^2, I_m\}$ .  $\Gamma_o$   
 173.  $O_h^5 = \{O^3, I\}$ .  $\Gamma_o'$   
 174.  $O_h^6 = \{O^3, I'\}$ .  $\Gamma_o'$   
 175.  $O_h^7 = \{O^4, I_m\}$ .  $\Gamma_o'$   
 176.  $O_h^8 = \{O^4, I_m'\}$ .  $\Gamma_o'$   
 177.  $O_h^9 = \{O^5, I\}$ .  $\Gamma_o''$   
 178.  $O_h^{10} = \{O^5, I\}$ .  $\Gamma_o''$

## HEXAGONAL SYSTEM.

## RHOMBOHEDRAL DIVISION.

*Tetartohedry.*—

The space-groups isomorphous with  $C_3$  can be obtained by combining the lattices  $\Gamma_h$  and  $\Gamma_{rh}$  with a three-fold screw axis. The translation component of this screw-motion is to be taken along the  $Z$ -axis.

179.  $C_3^1 = \left\{ A\left(\frac{2\pi}{3}\right), \Gamma_h \right\}$ .  $\Gamma_h$   
 180.  $C_3^2 = \left\{ A\left(\frac{2\pi}{3}, \frac{2\tau_2}{3}\right), \Gamma_h \right\}$ .  $\Gamma_h$   
 181.  $C_3^3 = \left\{ A\left(\frac{2\pi}{3}, \frac{4\tau_2}{3}\right), \Gamma_h \right\}$ .  $\Gamma_h$   
 182.  $C_3^4 = \left\{ A\left(\frac{2\pi}{3}\right), \Gamma_{rh} \right\}$ .  $\Gamma_{rh}$



*Paramorphic hemihedry.*—

The two space-groups  $C_{3i}^m$  can be obtained by combining groups  $C_3^m$  with an inversion (I).

$$183. C_{3i}^1 = \{C_3^1, I\}. \quad \Gamma_h$$

$$184. C_{3i}^2 = \{C_3^2, I\}. \quad \Gamma_{rh}$$

*Hemimorphic hemihedry.*—

The vertical reflecting plane will contain the vertical (Z) axis and either (1) the X-axis—of the point and isomorphous space-group—(AA' of figure 26), or (2) a line (AB of figure 26) which lies in the XY-plane and makes an angle of  $60^\circ$  with the X-axis. In the first case the reflection will be designated  $S_a$ , in the second  $S_s$ .

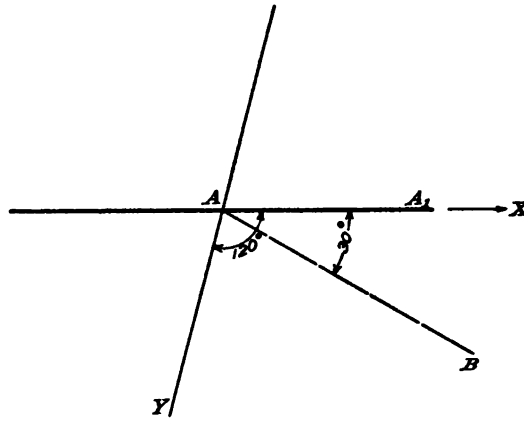

FIG. 26.

$$185. C_{3v}^1 = \{C_3^1, S_a\}. \quad \Gamma_h$$

$$186. C_{3v}^2 = \{C_3^1, S_s\}. \quad \Gamma_h$$

$$187. C_{3v}^3 = \{C_3^1, S_s(\tau_s)\}. \quad \Gamma_h$$

$$188. C_{3v}^4 = \{C_3^1, S_a(\tau_s)\}. \quad \Gamma_h$$

$$189. C_{3v}^5 = \{C_3^2, S_a\}. \quad \Gamma_{rh}$$

$$190. C_{3v}^6 = \{C_3^2, S_s(\tau_s)\}. \quad \Gamma_{rh}$$

*Enantiomorphic hemihedry.*—

The space-groups  $D_3^m$  result from operating upon groups  $C_3^m$  with a two-fold axis which has the position either of AA' of figure 26, ( $U_a$ ), or of AB, ( $U_s$ ).

$$191. D_3^1 = \{C_3^1, U_a\}. \quad \Gamma_h$$

$$192. D_3^2 = \{C_3^1, U_s\}. \quad \Gamma_h$$

$$193. D_3^3 = \{C_3^2, U_a\}. \quad \Gamma_h$$

$$194. D_3^4 = \{C_3^2, U_s\}. \quad \Gamma_h$$

$$195. D_3^5 = \{C_3^3, U_a\}. \quad \Gamma_h$$

$$196. D_3^6 = \{C_3^3, U_s\}. \quad \Gamma_h$$

$$197. D_3^7 = \{C_3^4, U_a\}. \quad \Gamma_{rh}$$

*Holohedry.*—

The groups  $D_{3d}^m$  are most easily obtained by combining groups of  $D_3^m$  with an inversion. This point of inversion will lie either at the intersection of a three-fold and a two-fold axis, (I), or midway between two such intersections (I').

198.  $D_{3d}^1 = \{D_3^1, I\}$ .  $\Gamma_h$   
 199.  $D_{3d}^2 = \{D_3^1, I'\}$ .  $\Gamma_h$   
 200.  $D_{3d}^3 = \{D_3^2, I\}$ .  $\Gamma_h$   
 201.  $D_{3d}^4 = \{D_3^2, I'\}$ .  $\Gamma_h$   
 202.  $D_{3d}^5 = \{D_3^3, I\}$ .  $\Gamma_{rh}$   
 203.  $D_{3d}^6 = \{D_3^3, I'\}$ .  $\Gamma_{rh}$

## HEXAGONAL DIVISION.

*Trigonal paramorphic hemihedry.*—

The single space-group isomorphous with  $C_3^h$  is obtained by reflecting  $C_3^1$  in a horizontal plane.

204.  $C_{3h}^1 = \{C_3^1, S_h\}$ .  $\Gamma_h$

*Trigonal holohedry.*—

The groups  $D_{3h}^m$  arise by reflecting groups  $D_3^m$  in a horizontal plane which either contains the two-fold axes, ( $S_h$ ), or lies midway between them, ( $S_m$ ).

205.  $D_{3h}^1 = \{D_3^1, S_h\}$ .  $\Gamma_h$   
 206.  $D_{3h}^2 = \{D_3^1, S_m\}$ .  $\Gamma_h$   
 207.  $D_{3h}^3 = \{D_3^2, S_h\}$ .  $\Gamma_h$   
 208.  $D_{3h}^4 = \{D_3^2, S_m\}$ .  $\Gamma_h$

*Hexagonal tetartohedry.*—

The space-groups isomorphous with  $C_6$  result from combining a six-fold screw-axis with the hexagonal lattice.

209.  $C_6^1 = \left\{ A\left(\frac{\pi}{3}\right), \Gamma_h \right\}$ .  $\Gamma_h$   
 210.  $C_6^2 = \left\{ A\left(\frac{\pi}{3}, \frac{\tau_s}{3}\right), \Gamma_h \right\}$ .  $\Gamma_h$   
 211.  $C_6^3 = \left\{ A\left(\frac{\pi}{3}, \frac{5\tau_s}{3}\right), \Gamma_h \right\}$ .  $\Gamma_h$   
 212.  $C_6^4 = \left\{ A\left(\frac{\pi}{3}, \frac{2\tau_s}{3}\right), \Gamma_h \right\}$ .  $\Gamma_h$   
 213.  $C_6^5 = \left\{ A\left(\frac{\pi}{3}, \frac{4\tau_s}{3}\right), \Gamma_h \right\}$ .  $\Gamma_h$   
 214.  $C_6^6 = \left\{ A\left(\frac{\pi}{3}, \tau_s\right), \Gamma_h \right\}$ .  $\Gamma_h$

*Hemimorphic hemihedry.*—

The groups  $C_{6v}^m$  are obtained by combining groups  $C_6^m$  with the operation of a vertical reflecting plane which passes through either the line AA' or the line AB of figure 26. The reflection in the plane through AA' will be designated as  $S_a$ .

215.  $C_{6v}^1 = \{C_6^1, S_a\}. \quad \Gamma_h$   
 216.  $C_{6v}^2 = \{C_6^1, S_a(\tau_a)\}. \quad \Gamma_h$   
 217.  $C_{6v}^3 = \{C_6^2, S_a\}. \quad \Gamma_h$   
 218.  $C_{6v}^4 = \{C_6^2, S_a(\tau_a)\}. \quad \Gamma_h$

*Paramorphic hemihedry.*—

The space-groups isomorphous with  $C_6^h$  can be obtained by reflecting groups  $C_6^m$  in a horizontal plane.

219.  $C_{6h}^1 = \{C_6^1, S_h\}. \quad \Gamma_h$   
 220.  $C_{6h}^2 = \{C_6^2, S_h\}. \quad \Gamma_h$

*Enantiomorphic hemihedry.*—

The space-groups  $D_6^m$  are most simply derived by combining groups  $C_6^m$  with the operation of a two-fold axis which coincides with the X-axis of coordinates of the point and isomorphous space-groups (AA' of figure 26). This two-fold rotation will be represented by  $U_a$ .

221.  $D_6^1 = \{C_6^1, U_a\}. \quad \Gamma_h$   
 222.  $D_6^2 = \{C_6^2, U_a\}. \quad \Gamma_h$   
 223.  $D_6^3 = \{C_6^3, U_a\}. \quad \Gamma_h$   
 224.  $D_6^4 = \{C_6^4, U_a\}. \quad \Gamma_h$   
 225.  $D_6^5 = \{C_6^5, U_a\}. \quad \Gamma_h$   
 226.  $D_6^6 = \{C_6^6, U_a\}. \quad \Gamma_h$

*Holohedry.*—

The groups  $D_{6h}^m$  result by combining groups  $D_6^m$  with an inversion which lies in the six-fold axis either at its intersections with the two-fold axes (I) or at points midway between such intersections, (I').

227.  $D_{6h}^1 = \{D_6^1, I\}. \quad \Gamma_h$   
 228.  $D_{6h}^2 = \{D_6^1, I'\}. \quad \Gamma_h$   
 229.  $D_{6h}^3 = \{D_6^2, I\}. \quad \Gamma_h$   
 230.  $D_{6h}^4 = \{D_6^2, I'\}. \quad \Gamma_h$

# CHAPTER III.

## THE APPLICATION OF THE THEORY OF SPACE- GROUPS TO CRYSTALS.\*

### UNITS OF STRUCTURE.

A space lattice has been defined† as the sum total of the points of intersection of any three sets of planes. These sets of planes partition the space into *units of structure*, all of the same size and shape. Such a unit is OABDEGFC of figure 18. There will thus be a unit corresponding to each of the 14 lattices; points of the lattice will be found at each of the corners of the unit prisms and in some cases other points of the lattice will lie in the center of the unit or at the centers of faces (as examples,  $\Gamma_0'''$  and  $\Gamma_0''$ ). If the lattice is a monoclinic lattice, the unit will be some sort of a monoclinic prism; if the lattice is cubic, the unit will be a cube, and so on.

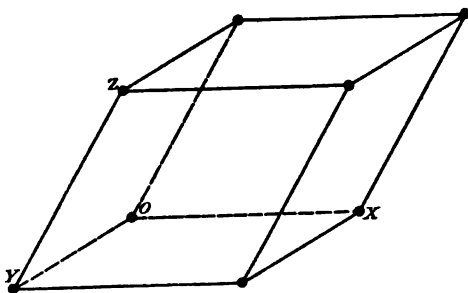

FIG. 27. The unit cell derived from  $\Gamma_0$ . The edges of this unit are of unequal lengths and make unequal angles with one another.

Just as a simple lattice can be divided into unit prisms by three sets of planes parallel to the axes of coordinates, so any space grouping of points, built upon some lattice, can be similarly divided. The fourteen units of structure characteristic of the fourteen space lattices are shown in figures 27 to 34. The number of the points of the lattice to be associated with a unit prism can be readily told. For instance, in the case of the simple cubic lattice,  $\Gamma_0$ , this number is one since each of the eight points of the lattice located at the eight corners of the cube is shared by the seven other cubes meeting at this point and there are no other lattice points contained in or touching the unit. For the same reason the unit cube of a space grouping having this lattice fundamental to it will have a single group of equivalent points (the  $n$  points about a single point of the lattice) associated with it; each of the 8 corner-points of the lattice will contribute to the cube one eighth, and each a different eighth, of the equivalent points ranged about it.

\* P. Niggli, *op. cit.*; Ralph W. G. Wyckoff, *Am. J. Sci.* 1, 127. 1921.

† See p. 22.

A consideration of the unit of the space-group already discussed in detail,  $C_{2h}^1$ , will make this more clear. The unit prism, OAFGBDE of figure 20 (see also figure 18), contains four equivalent points M, M', M'', and M''', the coordinates of which are M(xyz), M'(2 $\tau_x$ -x, 2 $\tau_y$ -y, z), M''(x, y, 2 $\tau_z$ -z) and M'''(2 $\tau_x$ -x, 2 $\tau_y$ -y, 2 $\tau_z$ -z). Since, however, the arrangement about every point of the lattice is the same as that about every other, it follows that corresponding points of the groups about neighboring points of the lattice are entirely similar. It is, then, so far as the expression of the relative positions of equivalent points is concerned, permissible to consider 2 $\tau_x$ -x=-x, -y=2 $\tau_y$ -y, and -z=2 $\tau_z$ -z.\* The coordinates of the four equivalent positions of the unit of structure of the space-group  $C_{2h}^1$  are thus:

$$xyz; \quad -x, -y, z; \quad x, y, -z; \quad -x, -y, -z$$

or, as it will hereafter be written:

$$xyz; \quad \bar{x}\bar{y}z; \quad xy\bar{z}; \quad \bar{x}\bar{y}\bar{z}.$$

The number of points of the lattice to be associated with the units of each of the other lattices can be similarly obtained and from this the coordinates

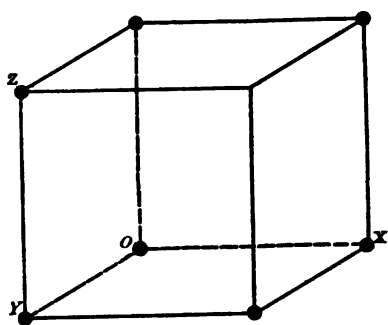

FIG. 28. If  $OX \neq OY \neq OZ$  and  $ZY$  is normal to the plane  $YOX$  but  $\angle YOX \neq 90^\circ$ , this is the unit of  $\Gamma_m$ ; if the three edges are mutually perpendicular and (1)  $OX \neq OY \neq OZ$ , the unit corresponds to  $\Gamma_o$ , (2) if  $OX = OY \neq OZ$  it corresponds to  $\Gamma_1(a)$  or (3) if  $OX = OY = OZ$  the unit is that of  $\Gamma_c$ .

which can be taken as typical of the positions of equivalent points within the unit of any space-group can be written down. The treatment of a slightly more complicated space-group will outline the necessary procedure. For this purpose we will take the space-group  $C_{2h}^4$  obtained by placing the point-group  $C_2^4$  at the points of the second monoclinic lattice  $\Gamma_m'$  (figure 29). The unit prism of this lattice proves to be a monoclinic prism with additional points of the lattice at the centers of two of its faces. The eight points of the lattice that are located at the corners of the prism serve, as with the space-group  $C_{2h}^1$ , to place within it the equivalent points of one group (in this instance, by definition, a point-group). One half of the points about each of the two points of the lattice at the diagonals of faces (and opposite halves) lie within the unit prism so that these two points of the lattice together contrive to place within the unit a second group of equivalent points. If O of figure 29 is taken as

\* This simplification is geometrically justified (1) since the unit prism that has been chosen has no particular physical significance but serves rather as a unit that is conveniently visualized and (2) because the coordinates adopted actually define a group of equivalent points which repeated along and parallel to the axes of coordinates will build up the entire assemblage. It is, moreover, justified analytically as an expression of the points associated with the unit prism itself (if one prefers to think of this unit) because as applied to the study of the structure of crystals, these coordinates define the interference effects to be expected from atoms placed at these positions; this definition involves sine and cosine terms within which 2 $\tau_x$ , 2 $\tau_y$ , and 2 $\tau_z$  in 2 $\tau_x$ -x, etc., disappear.



TABLE 2.

<i>Lattice.</i>	<i>Number of associated lattice points.</i>	<i>Coordinates of typical points.</i>	
<b>TRICLINIC SYSTEM.</b>			
1. $\Gamma_{tr}$	1	O (000).	Fig. 27.
<b>MONOCLINIC SYSTEM.</b>			
2. $\Gamma_m$	1	O (000).	Fig. 28.
3. $\Gamma_m'$	2	O (000); P (0, $\tau_y$ , $\tau_z$ ).	Fig. 29.
<b>ORTHORHOMBIC SYSTEM.</b>			
4. $\Gamma_o$	1	O (000).	Fig. 28.
5a. $\Gamma_o'$ (a)	2	O (000); P <sub>1</sub> ( $\tau_x$ , $\tau_y$ , 0).	Fig. 30.
b. $\Gamma_o'$ (b)	2	O (000); P (0, $\tau_y$ , $\tau_z$ ).	Fig. 29.
6. $\Gamma_o''$	4	O (000); P (0, $\tau_y$ , $\tau_z$ ); P <sub>1</sub> ( $\tau_x$ , $\tau_y$ , 0); P <sub>2</sub> ( $\tau_x$ , 0, $\tau_z$ ).	Fig. 31.
7. $\Gamma_o'''$	2	O (000); P <sub>3</sub> ( $\tau_x$ , $\tau_y$ , $\tau_z$ ).	Fig. 32.
<b>TETRAGONAL SYSTEM.</b>			
8a. $\Gamma_t$ (a)	1	O (000).	Fig. 28.
b. $\Gamma_t$ (b)	2	O (000); P <sub>1</sub> ( $\tau_x$ , $\tau_y$ , 0).	Fig. 30.
9a. $\Gamma_t'$ (a)	4	O (000); P (0, $\tau_y$ , $\tau_z$ ); P <sub>1</sub> ( $\tau_x$ , $\tau_y$ , 0); P <sub>2</sub> ( $\tau_x$ , 0, $\tau_z$ ).	Fig. 31.
b. $\Gamma_t'$ (b)	2	O (000); P <sub>3</sub> ( $\tau_x$ , $\tau_y$ , $\tau_z$ ).	Fig. 32.
<b>CUBIC SYSTEM.</b>			
10. $\Gamma_c$	1	O (000).	Fig. 28.
11. $\Gamma_c'$	4	O (000); P (0, $\tau_y$ , $\tau_z$ ); P <sub>1</sub> ( $\tau_x$ , $\tau_y$ , 0); P <sub>2</sub> ( $\tau_x$ , 0, $\tau_z$ ).	Fig. 31.
12. $\Gamma_c''$	2	O (000); P <sub>3</sub> ( $\tau_x$ , $\tau_y$ , $\tau_z$ ).	Fig. 32.
<b>HEXAGONAL SYSTEM.*</b>			
13. $\Gamma_{rh}$	1	O (000).	Fig. 33.
14. $\Gamma_h$	1	O (000).	Fig. 34.

## SPACE-GROUPS AND CRYSTALS.

Every crystal, considered as a regular arrangement of atoms in space, must possess the symmetry of some one of the 230 space-groups. The theory of space-groups, then, supplies a method with the aid of which it should be possible to represent all of the ways in which the atoms of a crystal can be arranged in space. If an atom of a crystal occupies such a position that it corresponds with the coordinate position  $xyz$  of an equivalent point of the space-group having the symmetry of the crystal, then symmetry demands that exactly similar atoms shall be found at positions corresponding to those of

\* The unit cell for  $\Gamma_h$  can also be taken as a base-centered rhombic prism, the lengths of whose sides stand in the ratio of

$$a : b : c = \sqrt{3} : 1 : c.$$

Niggli (op. cit.) has worked out upon this basis the analytical expression for all of the groups having  $\Gamma_h$  as the fundamental lattice. Such a unit is useful when it is desired to compare an hexagonal crystal with one exhibiting rhombic, tetragonal or cubic symmetry.

each of the other equivalent points of the space-group. Most crystals are built of atoms of more than one sort. As a consequence if we find the atoms of kind A occupying the positions of equivalent point  $xyz$  and the other points equivalent to it, the atoms of B will be found at some other positions developed from  $x'y'z'$ , and so on.

The atoms of a crystal may thus be thought of as occupying the positions of a sort of composite space-group developed by superimposing several sets of equivalent positions upon the same set of axes (and other elements of symmetry). The atoms of a crystal, as a result, must be arranged in groups with centers at the points of one of the space lattices. Such a group of atoms has

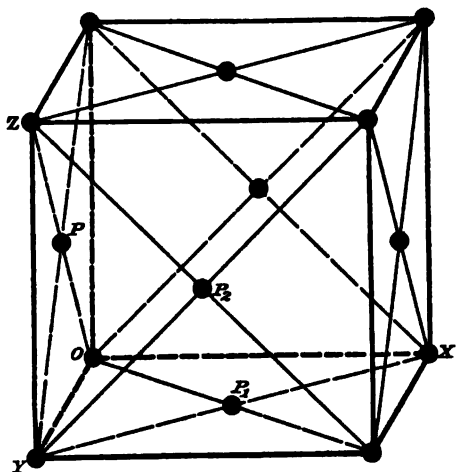

FIG. 31. A rectangular parallelepiped. If  $YZ \neq YO \neq OX$  it corresponds to  $\Gamma_0''$ , if  $YZ \neq YO = OX$  to  $\Gamma_1'(a)$ , or if  $YZ = YO = OX$  to  $\Gamma_1'$ .

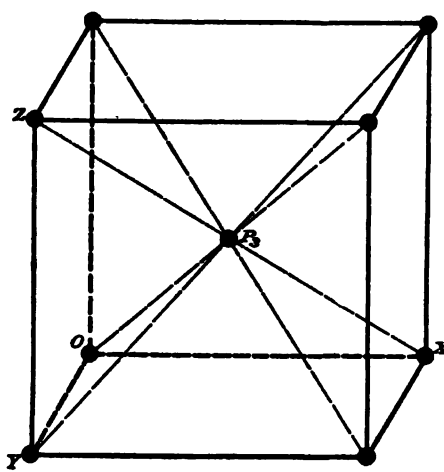

FIG. 32. A rectangular parallelepiped. If  $YZ \neq YO \neq OX$  it corresponds to  $\Gamma_0'''$ , if  $YZ \neq YO = OX$  to  $\Gamma_1'(b)$ , or if  $YZ = YO = OX$  to  $\Gamma_1''$ .

been called a *crystal molecule*. In this sense the crystal molecule is a purely geometrical conception and except under special conditions would not be thought of as possessing any physical significance.

It is possible, of course, to think of a crystal as divided, in the same way that a space-group can be divided, into a large number of unit prisms by sets of planes passing parallel to the three planes each of which contains two of the axes of coordinates. Measurements of the X-ray spectrum from the face of a crystal together with a knowledge of the density of the crystal can be made to yield the number of chemical molecules that are to be associated with this unit of structure.\* If a compound were of the type AB, where A is one kind of atom and B another, and if the atoms of A occupy the most general equivalent positions one of which is  $xyz$ , then there will be as many chemical molecules of AB associated with the unit prism as there are equiva-

\* The factor actually determined is  $n^2/m$ , where  $n$  is the "order" of the reflection spectrum and  $m$  is the number of chemical molecules associated with the unit prism. The value of  $n$  cannot, however, in general be determined so that  $m$  may usually have one of two or perhaps three values.



lent points in the unit. This number may under certain conditions be relatively great. For instance, in the case of the space-groups having the symmetry of the holohedry of the cubic system, the number of equivalent points of the point-group  $O^h$ , and of the other groups of points associated with a single point of the lattice, is 48. If then the fundamental lattice of a holohedral cubic space-group is the simple cubic lattice  $\Gamma_c$  and the compound crystallizes with this symmetry (as sodium chloride does, for instance), 48 (if all of the A atoms are alike and all of the B atoms are also alike, and more if they are not alike) chemical molecules of AB must be placed within the unit cell; if the lattice were, on the other hand, the face-centered lattice  $\Gamma'_c$  with four points of the lattice associated with the unit, this number of molecules of AB must be at least 192.

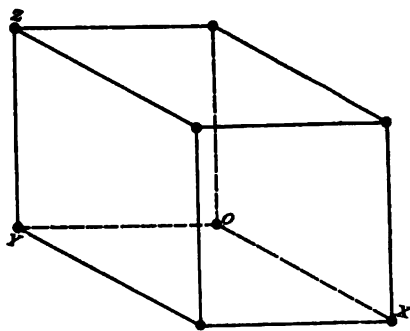

FIG. 33. If the three edges meeting at O are of equal lengths and make equal angles with one another, this unit corresponds to  $\Gamma_{rh}$ .

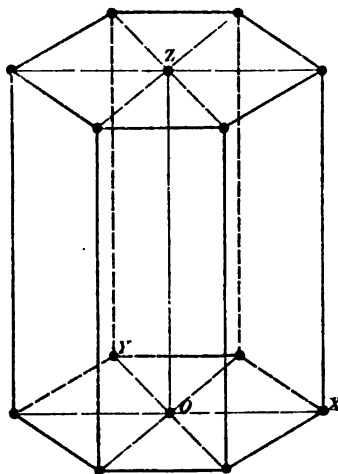

FIG. 34. If  $ZO \perp$  plane  $YOX$  and  $\angle YOX = 120^\circ$ , a rhombic prism two of the sides of whose base are  $XO$  and  $OY$  and of height  $OZ$  serves as the unit for  $\Gamma_h$ .

#### SPECIAL CASES.

If, however, the values of  $x$ ,  $y$  and  $z$  which express the positions of the atoms of A and B are such that the atoms lie upon some element of symmetry, two or more of the equivalent positions coincide and this number of molecules to be placed within the unit cell will be reduced. For instance if a point were to lie upon a plane of symmetry, it would of course be identical with its mirror image; or if it stood in a three-fold or four-fold axis of symmetry, three or four of the equivalent points would occupy the same position. In the space-group  $C_{2h}^1$  (figure 20) if  $z$  is equal to  $\tau_z$ , that is, to one half of the height of the unit prism, then the four equivalent points of the unit would occupy two positions ( $M$  coincides with  $M''$  and  $M'$  with  $M'''$ ) or if  $x$  is equal to  $\tau_x$ , and  $y$  to  $\tau_y$ , the four points will have two equivalent positions ( $M$  will coincide with  $M'$  and  $M''$  with  $M'''$ ). If  $x=y=z=0$  then the four points will all unite

at the origin and there will be but one equivalent position within the unit; the same is true if  $x=\tau_x$ ,  $y=\tau_y$  and  $z=\tau_z$ .

The results of all of the X-ray experimentation which has thus far been carried out seem to point to the fact that this number of chemical molecules to be contained within a unit cell is in all probability very much less than the number of most generally placed equivalent positions. As a consequence the determination of these special cases of the space-groups becomes of the utmost importance to the person interested in the structure of crystals.

A discussion of calcite, which has already been treated in detail by this procedure,\* will serve to indicate the need for these special cases of the space-groups. The X-ray measurements show that almost certainly two chemical molecules of calcium carbonate are to be associated with a unit rhombohedron. Calcite crystallizes with a symmetry which is that of the point-group  $D_3^d$ . Two space-groups isomorphous with  $D_3^d$ , namely  $D_{3d}^5$  and  $D_{3d}^6$ , have  $\Gamma_{rh}$  as the fundamental lattice. Since two chemical molecules of calcium carbonate are to be associated with the unit rhombohedron, two calcium atoms, two carbon atoms and six oxygen atoms must be placed within it. These two calcium atoms may conceivably be alike or they may be different one from the other; the same is true for the two carbon atoms; and the oxygen atoms may be for instance (1) all alike, (2) all different, (3) four alike and two different, (4) two sets of three like atoms or (5) three sets of two like atoms. Copying from page 157 it is seen that all of the potential atomic positions consistent with the space groups  $D_{3d}^5$  and  $D_{3d}^6$  are

SPACE-GROUP  $D_{3d}^5$ :

One equivalent position:

(a) 0 0 0.            (b)  $\frac{1}{2}$   $\frac{1}{2}$   $\frac{1}{2}$ .

Two equivalent positions:

(c) u u u;  $\bar{u}$   $\bar{u}$   $\bar{u}$ .

Three equivalent positions:

(d) 0 0  $\frac{1}{2}$ ; 0  $\frac{1}{2}$  0;  $\frac{1}{2}$  0 0.            (e) 0  $\frac{1}{2}$   $\frac{1}{2}$ ;  $\frac{1}{2}$   $\frac{1}{2}$  0;  $\frac{1}{2}$  0  $\frac{1}{2}$ .

Six equivalent positions:

(f) u  $\bar{u}$  0;  $\bar{u}$  0 u; 0 u  $\bar{u}$ ;  $\bar{u}$  u 0; u 0  $\bar{u}$ ; 0  $\bar{u}$  u.

(g) u  $\bar{u}$   $\frac{1}{2}$ ;  $\bar{u}$   $\frac{1}{2}$  u;  $\frac{1}{2}$  u  $\bar{u}$ ;  $\bar{u}$  u  $\frac{1}{2}$ ; u  $\frac{1}{2}$   $\bar{u}$ ;  $\frac{1}{2}$   $\bar{u}$  u.

(h) u u v; u v u; v u u;  $\bar{u}$   $\bar{u}$   $\bar{v}$ ;  $\bar{u}$   $\bar{v}$   $\bar{u}$ ;  $\bar{v}$   $\bar{u}$   $\bar{u}$ .

Twelve equivalent positions:

(i) xyz; yzx; zxy;  $\bar{y}\bar{x}\bar{z}$ ;  $\bar{x}\bar{z}\bar{y}$ ;  $\bar{z}\bar{y}\bar{x}$ ;  
 $\bar{x}\bar{y}\bar{z}$ ;  $\bar{y}\bar{z}\bar{x}$ ;  $\bar{z}\bar{x}\bar{y}$ ; yxz; xzy; zyx.

SPACE-GROUP  $D_{3d}^6$ :

Two equivalent positions:

(a) 0 0 0;            (b)  $\frac{1}{3}$   $\frac{1}{3}$   $\frac{1}{3}$ ;  $\frac{2}{3}$   $\frac{2}{3}$   $\frac{2}{3}$ .

Four equivalent positions:

(c) u u u;  $\bar{u}$   $\bar{u}$   $\bar{u}$ ;  $\frac{1}{2}$ -u,  $\frac{1}{2}$ -u,  $\frac{1}{2}$ -u; u+ $\frac{1}{2}$ , u+ $\frac{1}{2}$ , u+ $\frac{1}{2}$ .

\* Ralph W. G. Wyckoff, Am. J. Sci. 50, 317. 1920.

Six equivalent positions:

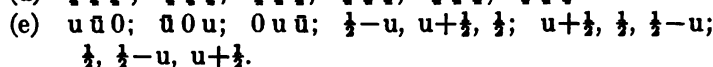

Twelve equivalent positions:

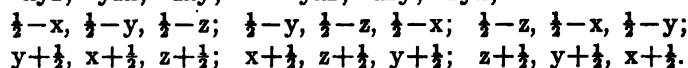
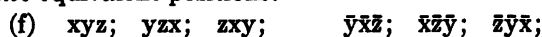

The attempt to write down on the basis of these coordinate positions the different arrangements of the atoms in calcite that are possible in the light of its symmetry immediately eliminates many of the possibilities just discussed. For instance it is clear that in neither case are there enough special cases of one equivalent position so that the two calcium atoms can be different and the two carbon atoms also different. The same fact shows that possibility (2) for the arrangement of the oxygen atoms may also be omitted from consideration; it can be similarly shown that there are in neither space-group sufficient special cases so that four of the oxygen atoms can be alike and two different. All of the possible ways for the atoms of calcite to be arranged can then be written as:\*

Arrangements arising from  $D_{3d}^5$ :

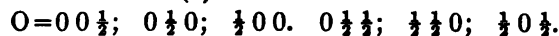
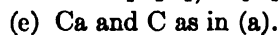
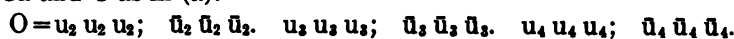
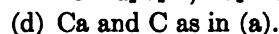
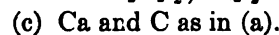
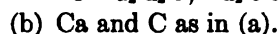
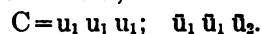
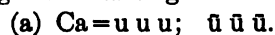

Arrangements arising from  $\Gamma_{3d}^6$ :

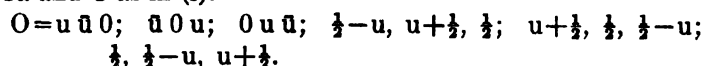
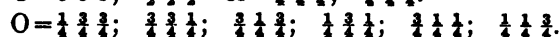

In this same manner all of the ways of arranging the atoms in any crystal can be written down from a knowledge of the number of molecules to be associated with the unit cell (as furnished by the X-ray spectrum measurements) and from a consideration of the special cases of the different space-groups possessing the symmetry of the crystal.

\* These arrangements, giving as we have seen the positions of the atoms within a unit cell which by simple translations along the axes of reference will locate all of the atoms in the crystal are in a form which is immediately usable for testing them by further X-ray measurements.

# CHAPTER IV.

## THE COMPLETE ANALYTICAL EXPRESSION OF THE SPACE-GROUPS.

Niggli has already recorded many of the simpler cases for the various space-groups. For some time the present writer has been engaged in working out analytically *all* of the special cases of the space-groups. The tables which follow are the results of these computations. They purport to give the coordinates of the most generally placed equivalent points and all of the special cases of these equivalent points contained within the unit of structure of each of the 230 space-groups.

The analytical determination of the special cases can be quite simply carried out by equating the coordinates of one point  $xyz$  with those of each of the other equivalent positions within the unit cell. This will yield a series of special cases (if any exist) which can be further specialized by applying this same process to the coordinates of these special positions. The continued use of this procedure will eventually yield all of the special cases for a space-group.\* By way of illustration the special cases of the space-group  $C_{2h}^1$  (page 49) will be deduced. The positions of the most generally placed equivalent points in the unit cell of this space-group are

$$xyz; \bar{x}\bar{y}z; xy\bar{z}; \bar{x}\bar{y}\bar{z}.$$

Equivalent point  $xyz$  will have the same position as equivalent point  $\bar{x}\bar{y}z$  when

- (1)  $x=\bar{x}$ ,  $y=\bar{y}$ ,  $z=z$ ; that is, when  $x=0$  or  $\frac{1}{2}(\times a)$ ,  $y=0$  or  $\frac{1}{2}(\times b)$  and  $z=w(\times c)$  where  $w$  is any fractional part of  $c$ . The lengths  $a$ ,  $b$ ,  $c$  are unit lengths along the X-, Y- and Z-axes.

It will have the same position as the point  $xy\bar{z}$  when

- (2)  $x=x$ ,  $y=y$ ,  $z=\bar{z}$ ; that is, when  $x=u(\times a)$ ,  $y=v(\times b)$ ,  $z=0$  or  $\frac{1}{2}(\times c)$ ;  $u$  and  $v$  are any fractional parts of  $a$  and  $b$ , respectively.

The points  $xyz$  and  $\bar{x}\bar{y}\bar{z}$  will coincide in position when

- (3)  $x=\bar{x}$ ,  $y=\bar{y}$ ,  $z=\bar{z}$ ; that is, when  $x=0$  or  $\frac{1}{2}(\times a)$ ,  $y=0$  or  $\frac{1}{2}(\times b)$ ,  $z=0$  or  $\frac{1}{2}(\times c)$ .

The special cases of this space-group then arise from using these values for  $x$ ,  $y$  and  $z$ . They are

From (1):

- (a) when  $x=0$ ,  $y=0$ , and  $z=w$ ; † then  $00w$ ;  $00\bar{w}$ .

\* The algebra of this process differs in certain details from the more ordinary kind. For instance there arises from our previous definitions the fact that  $0=1=2=\dots$ . Furthermore  $x=\bar{x}=0$  or  $\frac{1}{2}$ , and  $x=\frac{1}{2}-x=\frac{1}{2}$  or  $\frac{1}{2}$ , and more generally  $x=1/n-x=\frac{mn+1}{2n}$ , where  $n=1, 2, 3, \dots$ .

† In this example and in all of the tables which follow only the fractional parts of the unit lengths along the different coordinate axes will be stated. If for any reason absolute distances of points are desired, it is of course necessary to multiply the coordinate values given in these tables by the proper values of  $a$ ,  $b$  and  $c$ .

- (b) when  $x=0$ ,  $y=\frac{1}{2}$ ,  $z=w$ ; then  $0 \frac{1}{2} w$ ;  $0 \frac{1}{2} \bar{w}$ .  
 (c) when  $x=\frac{1}{2}$ ,  $y=0$ ,  $z=w$ ; then  $\frac{1}{2} 0 w$ ;  $\frac{1}{2} 0 \bar{w}$ .  
 (d) when  $x=\frac{1}{2}$ ,  $y=\frac{1}{2}$ ,  $z=w$ ; then  $\frac{1}{2} \frac{1}{2} w$ ;  $\frac{1}{2} \frac{1}{2} \bar{w}$ .

From (2):

- (e) when  $x=u$ ,  $y=v$ ,  $z=0$ ; then  $u v 0$ ;  $\bar{u} \bar{v} 0$ .  
 (f) when  $x=u$ ,  $y=v$ ,  $z=\frac{1}{2}$ ; then  $u v \frac{1}{2}$ ;  $\bar{u} \bar{v} \frac{1}{2}$ .

From (3):

- (g) when  $x=y=z=0$ ; then  $0 0 0$ .  
 (h) when  $x=\frac{1}{2}$ ,  $y=z=0$ ; then  $\frac{1}{2} 0 0$ .  
 (i) when  $x=z=0$ ,  $y=\frac{1}{2}$ ; then  $0 \frac{1}{2} 0$ .  
 (j) when  $x=y=0$ ,  $z=\frac{1}{2}$ ; then  $0 0 \frac{1}{2}$ .  
 (k) when  $x=0$ ,  $y$  and  $z=\frac{1}{2}$ ; then  $0 \frac{1}{2} \frac{1}{2}$ .  
 (l) when  $x$  and  $z=\frac{1}{2}$ ,  $y=0$ ; then  $\frac{1}{2} 0 \frac{1}{2}$ .  
 (m) when  $x$  and  $y=\frac{1}{2}$ ,  $z=0$ ; then  $\frac{1}{2} \frac{1}{2} 0$ .  
 (n) when  $x$ ,  $y$  and  $z=\frac{1}{2}$ ; then  $\frac{1}{2} \frac{1}{2} \frac{1}{2}$ .

We must now specialize by the same procedure each of the special cases (a) to (f). Inspection, however, shows that in the present instance this will lead to no *new* special positions. All of the special cases of the space-group  $C_{2h}^1$  are then defined by (a) to (n).

The other space-groups can all be specialized in the same fashion. These special positions for each space-group are given in the tables which follow.

## TRICLINIC SYSTEM.

### A. HEMIHEDRY.

#### SPACE-GROUP $C_1^1$ .

*One* equivalent position:

- (a)  $xyz$ .

### B. HOLOHEDRY.

#### SPACE-GROUP $C_1^1$ .

*One* equivalent position:

- |                         |   |
|-------------------------|---|
| (a) $0 0 0$ .           | (e) $\frac{1}{2} \frac{1}{2} 0$ .           |
| (b) $0 0 \frac{1}{2}$ . | (f) $\frac{1}{2} 0 \frac{1}{2}$ .           |
| (c) $0 \frac{1}{2} 0$ . | (g) $0 \frac{1}{2} \frac{1}{2}$ .           |
| (d) $\frac{1}{2} 0 0$ . | (h) $\frac{1}{2} \frac{1}{2} \frac{1}{2}$ . |

*Two* equivalent positions:

- (i)  $xyz$ ;  $\bar{x}\bar{y}\bar{z}$ .

## MONOCLINIC SYSTEM.

## A. HEMIHEDRY.

SPACE-GROUP  $C_2^1$ .*One equivalent position:*

- (a)
- $u v 0$
- . (b)
- $u v \frac{1}{2}$
- .

*Two equivalent positions:*

- (c)
- $xyz$
- ;
- $xy\bar{z}$
- .

SPACE-GROUP  $C_2^2$ .*Two equivalent positions:*

- (a)
- $xyz$
- ;
- $x+\frac{1}{2}, y, \bar{z}$
- .

SPACE-GROUP  $C_2^3$ .*Two equivalent positions:*

- (a)
- $u v 0$
- ;
- $u, v+\frac{1}{2}, \frac{1}{2}$
- .

*Four equivalent positions:*

- (b)
- $xyz$
- ;
- $xy\bar{z}$
- ;
- $x, y+\frac{1}{2}, z+\frac{1}{2}$
- ;
- $x, y+\frac{1}{2}, \frac{1}{2}-z$
- . ✓

SPACE-GROUP  $C_2^4$ .*Four equivalent positions:*

- (a)
- $xyz$
- ;
- $x+\frac{1}{2}, y, \bar{z}$
- ;
- $x, y+\frac{1}{2}, z+\frac{1}{2}$
- ;
- $x+\frac{1}{2}, y+\frac{1}{2}, \frac{1}{2}-z$
- .

## B. HEMIMORPHY.

SPACE-GROUP  $C_2^1$ .*One equivalent position:*

- (a)
- $0 0 u$
- . (b)
- $\frac{1}{2} 0 u$
- . (c)
- $0 \frac{1}{2} u$
- . (d)
- $\frac{1}{2} \frac{1}{2} u$
- .

*Two equivalent positions:*

- (e)
- $xyz$
- ;
- $\bar{x}\bar{y}z$
- .

SPACE-GROUP  $C_2^2$ .*Two equivalent positions:*

- (a)
- $xyz$
- ;
- $\bar{x}, \bar{y}, z+\frac{1}{2}$
- .

SPACE-GROUP  $C_2^3$ .*Two equivalent positions:*

- (a)
- $0 0 u$
- ;
- $0, \frac{1}{2}, u+\frac{1}{2}$
- . (b)
- $\frac{1}{2} 0 u$
- ;
- $\frac{1}{2}, \frac{1}{2}, u+\frac{1}{2}$
- .

*Four equivalent positions:*

- (c)
- $xyz$
- ;
- $\bar{x}\bar{y}z$
- ;
- $x, y+\frac{1}{2}, z+\frac{1}{2}$
- ;
- $\bar{x}, \frac{1}{2}-y, z+\frac{1}{2}$
- .

## C. HOLOHEDRY.

SPACE-GROUP  $C_{2h}^1$ .*One equivalent position:*

- (a)
- $0 0 0$
- . (e)
- $0 \frac{1}{2} \frac{1}{2}$
- .
- 
- (b)
- $0 0 \frac{1}{2}$
- . (f)
- $\frac{1}{2} 0 \frac{1}{2}$
- .
- 
- (c)
- $\frac{1}{2} 0 0$
- . (g)
- $\frac{1}{2} \frac{1}{2} 0$
- .
- 
- (d)
- $0 \frac{1}{2} 0$
- . (h)
- $\frac{1}{2} \frac{1}{2} \frac{1}{2}$
- .

SPACE-GROUP  $C_{2h}^1$  (continued).

Two equivalent positions:

- |   |   |
|---|---|
| (i) $00u$ ; $00\bar{u}$ .                     | (l) $\frac{1}{2}\frac{1}{2}u$ ; $\frac{1}{2}\frac{1}{2}\bar{u}$ . |
| (j) $0\frac{1}{2}u$ ; $0\frac{1}{2}\bar{u}$ . | (m) $uv0$ ; $\bar{u}\bar{v}0$ .                                   |
| (k) $\frac{1}{2}0u$ ; $\frac{1}{2}0\bar{u}$ . | (n) $uv\frac{1}{2}$ ; $\bar{u}\bar{v}\frac{1}{2}$ .               |

Four equivalent positions:

- (o)
- $xyz$
- ;
- $\bar{x}\bar{y}z$
- ;
- $xy\bar{z}$
- ;
- $\bar{x}\bar{y}\bar{z}$
- .

SPACE-GROUP  $C_{2h}^2$ .

Two equivalent positions:

- |   |   |
|---|---|
| (a) $00\frac{1}{2}$ ; $00\frac{3}{2}$ .                     | (d) $\frac{1}{2}\frac{1}{2}\frac{1}{2}$ ; $\frac{1}{2}\frac{1}{2}\frac{3}{2}$ . |
| (b) $0\frac{1}{2}\frac{1}{2}$ ; $0\frac{1}{2}\frac{3}{2}$ . | (e) $uv0$ ; $\bar{u}\bar{v}\frac{1}{2}$ .                                       |
| (c) $\frac{1}{2}0\frac{1}{2}$ ; $\frac{1}{2}0\frac{3}{2}$ . |   |

Four equivalent positions:

- (f)
- $xyz$
- ;
- $\bar{x}, \bar{y}, z+\frac{1}{2}$
- ;
- $xy\bar{z}$
- ;
- $\bar{x}, \bar{y}, \frac{1}{2}-z$
- .

These coordinate positions can be simplified by transferring the origin to the point  $\left(\frac{\tau_z}{2}\right)$  of this first set. They then become:

Two equivalent positions:

- |   |   |
|---|---|
| (a) $000$ ; $00\frac{1}{2}$ .                     | (d) $\frac{1}{2}\frac{1}{2}0$ ; $\frac{1}{2}\frac{1}{2}\frac{1}{2}$ . |
| (b) $0\frac{1}{2}0$ ; $0\frac{1}{2}\frac{1}{2}$ . | (e) $uv\frac{1}{2}$ ; $\bar{u}\bar{v}\frac{1}{2}$ .                   |
| (c) $\frac{1}{2}00$ ; $\frac{1}{2}0\frac{1}{2}$ . |   |

Four equivalent positions:

- (f)
- $xyz$
- ;
- $\bar{x}, \bar{y}, z+\frac{1}{2}$
- ;
- $x, y, \frac{1}{2}-z$
- ;
- $\bar{x}\bar{y}\bar{z}$
- .

SPACE-GROUP  $C_{2h}^3$ .

Two equivalent positions:

- |   |   |
|---|---|
| (a) $000$ ; $0\frac{1}{2}\frac{1}{2}$ . | (c) $\frac{1}{2}00$ ; $\frac{1}{2}\frac{1}{2}\frac{1}{2}$ . |
| (b) $00\frac{1}{2}$ ; $0\frac{1}{2}0$ . | (d) $\frac{1}{2}\frac{1}{2}0$ ; $\frac{1}{2}0\frac{1}{2}$ . |

Four equivalent positions:

- |   |
|---|
| (e) $0\frac{1}{2}\frac{1}{2}$ ; $0\frac{3}{2}\frac{1}{2}$ ; $0\frac{1}{2}\frac{3}{2}$ ; $0\frac{3}{2}\frac{3}{2}$ .   |
| (f) $\frac{1}{2}\frac{1}{2}\frac{1}{2}$ ; $\frac{1}{2}\frac{3}{2}\frac{1}{2}$ ; $\frac{1}{2}\frac{1}{2}\frac{3}{2}$ ; $\frac{1}{2}\frac{3}{2}\frac{3}{2}$ . |
| (g) $00u$ ; $00\bar{u}$ ; $0, \frac{1}{2}, u+\frac{1}{2}$ ; $0, \frac{1}{2}, \frac{1}{2}-u$ .   |
| (h) $\frac{1}{2}0u$ ; $\frac{1}{2}0\bar{u}$ ; $\frac{1}{2}, \frac{1}{2}, u+\frac{1}{2}$ ; $\frac{1}{2}, \frac{1}{2}, \frac{1}{2}-u$ .                       |
| (i) $uv0$ ; $\bar{u}\bar{v}0$ ; $u, v+\frac{1}{2}, \frac{1}{2}$ ; $\bar{u}, \frac{1}{2}-v, \frac{1}{2}$ .   |

Eight equivalent positions:

- |  |
|--|
| (j) $xyz$ ; $\bar{x}\bar{y}z$ ; $x, y+\frac{1}{2}, z+\frac{1}{2}$ ; $\bar{x}, \frac{1}{2}-y, z+\frac{1}{2}$ ;<br>$\bar{x}\bar{y}\bar{z}$ ; $xy\bar{z}$ ; $\bar{x}, \frac{1}{2}-y, \frac{1}{2}-z$ ; $x, y+\frac{1}{2}, \frac{1}{2}-z$ . |
|--|

SPACE-GROUP  $C_{2h}^4$ .

Two equivalent positions:

- |   |   |
|---|---|
| (a) $\frac{1}{2}00$ ; $\frac{3}{2}00$ .   | (d) $\frac{1}{2}\frac{1}{2}0$ ; $\frac{3}{2}\frac{1}{2}0$ . |
| (b) $\frac{1}{2}\frac{1}{2}\frac{1}{2}$ ; $\frac{3}{2}\frac{1}{2}\frac{1}{2}$ ; | (e) $00u$ ; $\frac{1}{2}0\bar{u}$ .                         |
| (c) $\frac{1}{2}0\frac{1}{2}$ ; $\frac{3}{2}0\frac{1}{2}$ .                     | (f) $\frac{1}{2}\frac{1}{2}u$ ; $0\frac{1}{2}\bar{u}$ .     |

SPACE-GROUP  $C_{2h}^4$  (continued).

Four equivalent positions:

(g)  $xyz; \bar{x}\bar{y}z; x+\frac{1}{2}, y, \bar{z}; \frac{1}{2}-x, \bar{y}, z$ .

These coordinate positions can be simplified by transferring the origin to the point  $\left(\frac{\tau_x}{2}\right)$  of this first set. They then become:

Two equivalent positions:

(a)  $000; \frac{1}{2}00$ . (d)  $0\frac{1}{2}0; \frac{1}{2}\frac{1}{2}0$ .  
 (b)  $0\frac{1}{2}\frac{1}{2}; \frac{1}{2}\frac{1}{2}\frac{1}{2}$ . (e)  $\frac{1}{4}0u; \frac{3}{4}0\bar{u}$ .  
 (c)  $00\frac{1}{2}; \frac{1}{2}0\frac{1}{2}$ . (f)  $\frac{3}{4}\frac{1}{2}u; \frac{1}{4}\frac{1}{2}\bar{u}$ .

Four equivalent positions:

(g)  $xyz; \frac{1}{2}-x, \bar{y}, z; x+\frac{1}{2}, y, \bar{z}; \bar{x}\bar{y}\bar{z}$ .

SPACE-GROUP  $C_{2h}^5$ .

Two equivalent positions:

(a)  $\frac{1}{2}0\frac{1}{2}; \frac{3}{4}0\frac{3}{4}$ . (c)  $\frac{1}{4}0\frac{3}{4}; \frac{3}{4}0\frac{1}{4}$ .  
 (b)  $\frac{1}{4}\frac{1}{4}\frac{1}{4}; \frac{3}{4}\frac{3}{4}\frac{3}{4}$ . (d)  $\frac{1}{4}\frac{3}{4}\frac{3}{4}; \frac{3}{4}\frac{1}{4}\frac{1}{4}$ .

Four equivalent positions:

(e)  $xyz; \bar{x}, \bar{y}, z+\frac{1}{2}; x+\frac{1}{2}, y, \bar{z}; \frac{1}{2}-x, \bar{y}, \frac{1}{2}-z$ .

These coordinate positions can be simplified by transferring the origin to the point  $\left(\frac{\tau_x}{2}, \frac{\tau_z}{2}\right)$  of this first set. They then become:

Two equivalent positions:

(a)  $000; \frac{1}{2}0\frac{1}{2}$ . (c)  $00\frac{1}{2}; \frac{1}{2}00$ .  
 (b)  $0\frac{1}{2}0; \frac{1}{2}\frac{1}{2}\frac{1}{2}$ . (d)  $0\frac{1}{2}\frac{1}{2}; \frac{1}{2}\frac{1}{2}0$ .

Four equivalent positions:

(e)  $xyz; \frac{1}{2}-x, \bar{y}, z+\frac{1}{2}; x+\frac{1}{2}, y, \frac{1}{2}-z; \bar{x}\bar{y}\bar{z}$ .

SPACE-GROUP  $C_{2h}^6$ .

Four equivalent positions:

(a)  $\frac{1}{4}00; \frac{3}{4}00; \frac{1}{4}\frac{1}{2}\frac{1}{2}; \frac{3}{4}\frac{1}{2}\frac{1}{2}$ .  
 (b)  $\frac{1}{4}0\frac{1}{2}; \frac{3}{4}0\frac{1}{2}; \frac{1}{4}\frac{1}{2}0; \frac{3}{4}\frac{1}{2}0$ .  
 (c)  $\frac{1}{4}\frac{1}{4}\frac{1}{4}; \frac{3}{4}\frac{3}{4}\frac{1}{4}; \frac{3}{4}\frac{1}{4}\frac{3}{4}; \frac{1}{4}\frac{3}{4}\frac{3}{4}$ .  
 (d)  $\frac{3}{4}\frac{3}{4}\frac{3}{4}; \frac{1}{4}\frac{1}{4}\frac{3}{4}; \frac{1}{4}\frac{3}{4}\frac{1}{4}; \frac{3}{4}\frac{1}{4}\frac{1}{4}$ .  
 (e)  $00u; \frac{1}{2}0\bar{u}; 0, \frac{1}{2}, u+\frac{1}{2}; \frac{1}{2}, \frac{1}{2}, \frac{1}{2}-u$ .

Eight equivalent positions:

(f)  $xyz; \bar{x}\bar{y}z; x+\frac{1}{2}, y, \bar{z}; \frac{1}{2}-x, \bar{y}, \bar{z};$   
 $x, y+\frac{1}{2}, z+\frac{1}{2}; \bar{x}, \frac{1}{2}-y, z+\frac{1}{2}; x+\frac{1}{2}, y+\frac{1}{2}, \frac{1}{2}-z;$   
 $\frac{1}{2}-x, \frac{1}{2}-y, \frac{1}{2}-z$ .

A change of origin to the point  $\left(\frac{\tau_x}{2}\right)$  of this set of coordinates would simplify

(a) and (b).



## ORTHORHOMBIC SYSTEM.

## A. HEMIMORPHY.

SPACE-GROUP  $C_{2v}^1$ .*One equivalent position:*

- (a)  $00u$ .                      (c)  $\frac{1}{2}0u$ .  
 (b)  $0\frac{1}{2}u$ .                      (d)  $\frac{1}{2}\frac{1}{2}u$ .

*Two equivalent positions:*

- (e)  $u0v$ ;  $\bar{u}0v$ .                      (g)  $0uv$ ;  $0\bar{u}v$ .  
 (f)  $u\frac{1}{2}v$ ;  $\bar{u}\frac{1}{2}v$ .                      (h)  $\frac{1}{2}uv$ ;  $\frac{1}{2}\bar{u}v$ .

*Four equivalent positions:*

- (i)  $xyz$ ;  $\bar{x}\bar{y}z$ ;  $x\bar{y}z$ ;  $\bar{x}yz$ .

SPACE-GROUP  $C_{2v}^2$ .*Two equivalent positions:*

- (a)  $u0v$ ;  $\bar{u}, 0, v+\frac{1}{2}$ .                      (b)  $u\frac{1}{2}v$ ;  $\bar{u}, \frac{1}{2}, v+\frac{1}{2}$ .

*Four equivalent positions:*

- (c)  $xyz$ ;  $\bar{x}, \bar{y}, z+\frac{1}{2}$ ;  $x\bar{y}z$ ;  $\bar{x}, y, z+\frac{1}{2}$ .

SPACE-GROUP  $C_{2v}^3$ .*Two equivalent positions:*

- (a)  $00u$ ;  $0, 0, u+\frac{1}{2}$ .                      (c)  $\frac{1}{2}0u$ ;  $\frac{1}{2}, 0, u+\frac{1}{2}$ .  
 (b)  $0\frac{1}{2}u$ ;  $0, \frac{1}{2}, u+\frac{1}{2}$ .                      (d)  $\frac{1}{2}\frac{1}{2}u$ ;  $\frac{1}{2}, \frac{1}{2}, u+\frac{1}{2}$ .

*Four equivalent positions:*

- (e)  $xyz$ ;  $\bar{x}\bar{y}z$ ;  $x, \bar{y}, z+\frac{1}{2}$ ;  $\bar{x}, y, z+\frac{1}{2}$ .

SPACE-GROUP  $C_{2v}^4$ .*Two equivalent positions:*

- (a)  $00u$ ;  $\frac{1}{2}0u$ .                      (b)  $\frac{1}{2}\frac{1}{2}u$ ;  $0\frac{1}{2}u$ .                      (c)  $\frac{1}{4}uv$ ;  $\frac{3}{4}\bar{u}v$ .

*Four equivalent positions:*

- (d)  $xyz$ ;  $\bar{x}\bar{y}z$ ;  $x+\frac{1}{2}, \bar{y}, z$ ;  $\frac{1}{2}-x, y, z$ .

SPACE-GROUP  $C_{2v}^5$ .*Four equivalent positions:*

- (a)  $xyz$ ;  $\bar{x}, \bar{y}, z+\frac{1}{2}$ ;  $x+\frac{1}{2}, \bar{y}, z$ ;  $\frac{1}{2}-x, y, z+\frac{1}{2}$ .

SPACE-GROUP  $C_{2v}^6$ .*Two equivalent positions:*

- (a)  $00u$ ;  $\frac{1}{2}, 0, u+\frac{1}{2}$ .                      (b)  $\frac{1}{2}\frac{1}{2}u$ ;  $0, \frac{1}{2}, u+\frac{1}{2}$ .

*Four equivalent positions:*

- (c)  $xyz$ ;  $\bar{x}\bar{y}z$ ;  $x+\frac{1}{2}, \bar{y}, z+\frac{1}{2}$ ;  $\frac{1}{2}-x, y, z+\frac{1}{2}$ .

SPACE-GROUP  $C_{2v}^7$ .*Two* equivalent positions:

(a)  $\frac{1}{2} u v$ ;  $\frac{1}{2}, 0, v + \frac{1}{2}$ .

*Four* equivalent positions:

(b)  $xyz$ ;  $\bar{x}, \bar{y}, z + \frac{1}{2}$ ;  $x + \frac{1}{2}, \bar{y}, z + \frac{1}{2}$ ;  $\frac{1}{2} - x, y, z$ .

A slight simplification can be effected by transferring the origin of coordinates to  $\frac{7x}{2}$  of this first set. They then become:

*Two* equivalent positions:

(a)  $0 u v$ ;  $\frac{1}{2}, 0, v + \frac{1}{2}$ .

*Four* equivalent positions:

(b)  $xyz$ ;  $\frac{1}{2} - x, \bar{y}, z + \frac{1}{2}$ ;  $x + \frac{1}{2}, \bar{y}, z + \frac{1}{2}$ ;  $\bar{x}yz$ .

SPACE-GROUP  $C_{2v}^8$ .*Two* equivalent positions:

(a)  $0 0 u$ ;  $\frac{1}{2} \frac{1}{2} u$ . (b)  $\frac{1}{2} 0 u$ ;  $0 \frac{1}{2} u$ .

*Four* equivalent positions:

(c)  $xyz$ ;  $\bar{x}\bar{y}z$ ;  $x + \frac{1}{2}, \frac{1}{2} - y, z$ ;  $\frac{1}{2} - x, y + \frac{1}{2}, z$ .

SPACE-GROUP  $C_{2v}^9$ .*Four* equivalent positions:

(a)  $xyz$ ;  $\bar{x}, \bar{y}, z + \frac{1}{2}$ ;  $x + \frac{1}{2}, \frac{1}{2} - y, z$ ;  $\frac{1}{2} - x, y + \frac{1}{2}, z + \frac{1}{2}$ .

SPACE-GROUP  $C_{2v}^{10}$ .*Two* equivalent positions:

(a)  $0 0 u$ ;  $\frac{1}{2}, \frac{1}{2}, u + \frac{1}{2}$ . (b)  $0 \frac{1}{2} u$ ;  $\frac{1}{2}, 0, u + \frac{1}{2}$ .

*Four* equivalent positions:

(c)  $xyz$ ;  $\bar{x}\bar{y}z$ ;  $x + \frac{1}{2}, \frac{1}{2} - y, z + \frac{1}{2}$ ;  $\frac{1}{2} - x, y + \frac{1}{2}, z + \frac{1}{2}$ .

SPACE-GROUP  $C_{2v}^{11}$ .*Two* equivalent positions:

(a)  $0 0 u$ ;  $\frac{1}{2} \frac{1}{2} u$ . (b)  $\frac{1}{2} 0 u$ ;  $0 \frac{1}{2} u$ .

*Four* equivalent positions:

(c)  $\frac{1}{2} \frac{1}{2} u$ ;  $\frac{1}{2} \frac{1}{2} u$ ;  $\frac{1}{2} \frac{1}{2} u$ ;  $\frac{1}{2} \frac{1}{2} u$ .

(d)  $u 0 v$ ;  $\bar{u} 0 v$ ;  $u + \frac{1}{2}, \frac{1}{2}, v$ ;  $\frac{1}{2} - u, \frac{1}{2}, v$ .

(e)  $0 u v$ ;  $0 \bar{u} v$ ;  $\frac{1}{2}, u + \frac{1}{2}, v$ ;  $\frac{1}{2}, \frac{1}{2} - u, v$ .

*Eight* equivalent positions:

(f)  $xyz$ ;  $\bar{x}\bar{y}z$ ;  $x\bar{y}z$ ;  $\bar{x}yz$ ;  
 $x + \frac{1}{2}, y + \frac{1}{2}, z$ ;  $\frac{1}{2} - x, \frac{1}{2} - y, z$ ;  $x + \frac{1}{2}, \frac{1}{2} - y, z$ ;  $\frac{1}{2} - x, y + \frac{1}{2}, z$ .

SPACE-GROUP  $C_{2v}^{12}$ .*Four equivalent positions:*

(a)  $u\ 0\ v$ ;  $u, 0, v+\frac{1}{2}$ ;  $u+\frac{1}{2}, \frac{1}{2}, v$ ;  $\frac{1}{2}-u, \frac{1}{2}, v+\frac{1}{2}$ .

*Eight equivalent positions:*

(b)  $xyz$ ;  $\bar{x}, \bar{y}, z+\frac{1}{2}$ ;  $x\bar{y}z$ ;  $\bar{x}, y, z+\frac{1}{2}$ ;  
 $x+\frac{1}{2}, y+\frac{1}{2}, z$ ;  $\frac{1}{2}-x, \frac{1}{2}-y, z+\frac{1}{2}$ ;  $x+\frac{1}{2}, \frac{1}{2}-y, z$ ;  
 $\frac{1}{2}-x, y+\frac{1}{2}, z+\frac{1}{2}$ .

SPACE-GROUP  $C_{2v}^{13}$ .*Four equivalent positions:*

(a)  $0\ 0\ u$ ;  $\frac{1}{2}\ \frac{1}{2}\ u$ ;  $0, 0, u+\frac{1}{2}$ ;  $\frac{1}{2}, \frac{1}{2}, u+\frac{1}{2}$ .

(b)  $0\ \frac{1}{2}\ u$ ;  $\frac{1}{2}\ 0\ u$ ;  $0, \frac{1}{2}, u+\frac{1}{2}$ ;  $\frac{1}{2}, 0, u+\frac{1}{2}$ .

(c)  $\frac{1}{4}\ \frac{1}{4}\ u$ ;  $\frac{3}{4}\ \frac{3}{4}\ u$ ;  $\frac{1}{4}, \frac{3}{4}, u+\frac{1}{2}$ ;  $\frac{3}{4}, \frac{1}{4}, u+\frac{1}{2}$ .

*Eight equivalent positions:*

(d)  $xyz$ ;  $\bar{x}\bar{y}z$ ;  $x, \bar{y}, z+\frac{1}{2}$ ;  $\bar{x}, y, z+\frac{1}{2}$ ;  
 $x+\frac{1}{2}, y+\frac{1}{2}, z$ ;  $\frac{1}{2}-x, \frac{1}{2}-y, z$ ;  $x+\frac{1}{2}, \frac{1}{2}-y, z+\frac{1}{2}$ ;  
 $\frac{1}{2}-x, y+\frac{1}{2}, z+\frac{1}{2}$ .

SPACE-GROUP  $C_{2v}^{14}$ .*Two equivalent positions:*

(a)  $0\ 0\ u$ ;  $0, \frac{1}{2}, u+\frac{1}{2}$ . (b)  $\frac{1}{2}\ \frac{1}{2}\ u$ ;  $\frac{1}{2}, 0, u+\frac{1}{2}$ .

*Four equivalent positions:*

(c)  $u\ 0\ v$ ;  $\bar{u}\ 0\ v$ ;  $u, \frac{1}{2}, v+\frac{1}{2}$ ;  $\bar{u}, \frac{1}{2}, v+\frac{1}{2}$ .

(d)  $0\ u\ v$ ;  $0\ \bar{u}\ v$ ;  $0, u+\frac{1}{2}, v+\frac{1}{2}$ ;  $0, \frac{1}{2}-u, v+\frac{1}{2}$ .

(e)  $\frac{1}{2}\ u\ v$ ;  $\frac{1}{2}\ \bar{u}\ v$ ;  $\frac{1}{2}, u+\frac{1}{2}, v+\frac{1}{2}$ ;  $\frac{1}{2}, \frac{1}{2}-u, v+\frac{1}{2}$ .

*Eight equivalent positions:*

(f)  $xyz$ ;  $\bar{x}\bar{y}z$ ;  $x\bar{y}z$ ;  $\bar{x}yz$ ;  
 $x, y+\frac{1}{2}, z+\frac{1}{2}$ ;  $\bar{x}, \frac{1}{2}-y, z+\frac{1}{2}$ ;  $x, \frac{1}{2}-y, z+\frac{1}{2}$ ;  $\bar{x}, y+\frac{1}{2}, z+\frac{1}{2}$ .

SPACE-GROUP  $C_{2v}^{15}$ .*Four equivalent positions:*

(a)  $0\ 0\ u$ ;  $0\ \frac{1}{2}\ u$ ;  $0, 0, u+\frac{1}{2}$ ;  $0, \frac{1}{2}, u+\frac{1}{2}$ .

(b)  $\frac{1}{2}\ \frac{1}{2}\ u$ ;  $\frac{1}{2}\ 0\ u$ ;  $\frac{1}{2}, \frac{1}{2}, u+\frac{1}{2}$ ;  $\frac{1}{2}, 0, u+\frac{1}{2}$ .

(c)  $u\ \frac{1}{2}\ v$ ;  $\bar{u}\ \frac{1}{2}\ v$ ;  $u, \frac{1}{2}, v+\frac{1}{2}$ ;  $\bar{u}, \frac{1}{2}, v+\frac{1}{2}$ .

*Eight equivalent positions:*

(d)  $xyz$ ;  $\bar{x}\bar{y}z$ ;  $x, \bar{y}, z+\frac{1}{2}$ ;  $\bar{x}, y, z+\frac{1}{2}$ ;  
 $x, y+\frac{1}{2}, z+\frac{1}{2}$ ;  $\bar{x}, \frac{1}{2}-y, z+\frac{1}{2}$ ;  $x, \frac{1}{2}-y, z$ ;  $\bar{x}, y+\frac{1}{2}, z$ .

SPACE-GROUP  $C_{2v}^{16}$ .*Four equivalent positions:*

(a)  $0\ 0\ u$ ;  $\frac{1}{2}\ 0\ u$ ;  $0, \frac{1}{2}, u+\frac{1}{2}$ ;  $\frac{1}{2}, \frac{1}{2}, u+\frac{1}{2}$ .

(b)  $\frac{1}{4}\ u\ v$ ;  $\frac{3}{4}\ \bar{u}\ v$ ;  $\frac{1}{4}, u+\frac{1}{2}, v+\frac{1}{2}$ ;  $\frac{3}{4}, \frac{1}{2}-u, v+\frac{1}{2}$ .

SPACE-GROUP  $C_{2v}^{16}$  (continued).

Eight equivalent positions:

$$(c) \begin{array}{cccc} xyz; & \bar{x}\bar{y}z; & x+\frac{1}{2}, \bar{y}, z; & \frac{1}{2}-x, y, z; \\ x, y+\frac{1}{2}, z+\frac{1}{2}; & \bar{x}, \frac{1}{2}-y, z+\frac{1}{2}; & x+\frac{1}{2}, \frac{1}{2}-y, z+\frac{1}{2}; & \\ & & & \frac{1}{2}-x, y+\frac{1}{2}, z+\frac{1}{2}. \end{array}$$

SPACE-GROUP  $C_{2v}^{17}$ .

Four equivalent positions:

$$(a) 00u; \quad \frac{1}{2}\frac{1}{2}u; \quad \frac{1}{2}, 0, u+\frac{1}{2}; \quad 0, \frac{1}{2}, u+\frac{1}{2}.$$

Eight equivalent positions:

$$(b) \begin{array}{cccc} xyz; & \bar{x}\bar{y}z; & x+\frac{1}{2}, \bar{y}, z+\frac{1}{2}; & \frac{1}{2}-x, y, z+\frac{1}{2}; \\ x, y+\frac{1}{2}, z+\frac{1}{2}; & \bar{x}, \frac{1}{2}-y, z+\frac{1}{2}; & x+\frac{1}{2}, \frac{1}{2}-y, z; & \frac{1}{2}-x, y+\frac{1}{2}, z. \end{array}$$

SPACE-GROUP  $C_{2v}^{18}$ .

Four equivalent positions:

$$(a) 00u; \quad \frac{1}{2}\frac{1}{2}u; \quad \frac{1}{2}, 0, u+\frac{1}{2}; \quad 0, \frac{1}{2}, u+\frac{1}{2}.$$

Eight equivalent positions:

$$(b) \begin{array}{cccc} \frac{1}{2}\frac{1}{2}u; & \frac{2}{2}\frac{2}{2}u; & \frac{1}{2}, \frac{1}{2}, u+\frac{1}{2}; & \frac{2}{2}, \frac{2}{2}, u+\frac{1}{2}; \\ \frac{1}{2}\frac{2}{2}u; & \frac{2}{2}\frac{1}{2}u; & \frac{1}{2}, \frac{2}{2}, u+\frac{1}{2}; & \frac{2}{2}, \frac{1}{2}, u+\frac{1}{2}. \end{array}$$

$$(c) \begin{array}{cccc} u0v; & \bar{u}0v; & u+\frac{1}{2}, \frac{1}{2}, v; & \frac{1}{2}-u, \frac{1}{2}, v; \\ u+\frac{1}{2}, 0, v+\frac{1}{2}; & \frac{1}{2}-u, 0, v+\frac{1}{2}; & u, \frac{1}{2}, v+\frac{1}{2}; & \bar{u}, \frac{1}{2}, v+\frac{1}{2}. \end{array}$$

$$(d) \begin{array}{cccc} 0uv; & 0\bar{u}v; & \frac{1}{2}, u+\frac{1}{2}, v; & \frac{1}{2}, \frac{1}{2}-u, v; \\ \frac{1}{2}, u, v+\frac{1}{2}; & \frac{1}{2}, \bar{u}, v+\frac{1}{2}; & 0, u+\frac{1}{2}, v+\frac{1}{2}; & 0, \frac{1}{2}-u, v+\frac{1}{2}. \end{array}$$

Sixteen equivalent positions:

$$(e) \begin{array}{cccc} xyz; & \bar{x}\bar{y}z; & x\bar{y}z; & \bar{x}yz; \\ x+\frac{1}{2}, y+\frac{1}{2}, z; & \frac{1}{2}-x, \frac{1}{2}-y, z; & x+\frac{1}{2}, \frac{1}{2}-y, z; & \frac{1}{2}-x, y+\frac{1}{2}, z; \\ x+\frac{1}{2}, y, z+\frac{1}{2}; & \frac{1}{2}-x, \bar{y}, z+\frac{1}{2}; & x+\frac{1}{2}, \bar{y}, z+\frac{1}{2}; & \frac{1}{2}-x, y, z+\frac{1}{2}; \\ x, y+\frac{1}{2}, z+\frac{1}{2}; & \bar{x}, \frac{1}{2}-y, z+\frac{1}{2}; & x, \frac{1}{2}-y, z+\frac{1}{2}; & \bar{x}, y+\frac{1}{2}, z+\frac{1}{2}. \end{array}$$

SPACE-GROUP  $C_{2v}^{19}$ .

Eight equivalent positions:

$$(a) 00u; \quad \frac{1}{2}\frac{1}{2}u; \quad \frac{1}{2}, \frac{1}{2}, u+\frac{1}{2}; \quad \frac{2}{2}, \frac{2}{2}, u+\frac{1}{2}; \\ \frac{1}{2}, 0, u+\frac{1}{2}; \quad 0, \frac{1}{2}, u+\frac{1}{2}; \quad \frac{2}{2}, \frac{1}{2}, u+\frac{1}{2}; \quad \frac{1}{2}, \frac{2}{2}, u+\frac{1}{2}.$$

Sixteen equivalent positions:

$$(b) \begin{array}{cccc} xyz; & \bar{x}\bar{y}z; & x+\frac{1}{2}, \frac{1}{2}-y, z+\frac{1}{2}; & \\ & & & \frac{1}{2}-x, y+\frac{1}{2}, z+\frac{1}{2}; \\ x+\frac{1}{2}, y+\frac{1}{2}, z; & \frac{1}{2}-x, \frac{1}{2}-y, z; & x+\frac{2}{2}, \frac{2}{2}-y, z+\frac{1}{2}; & \\ & & & \frac{2}{2}-x, y+\frac{2}{2}, z+\frac{1}{2}; \\ x+\frac{1}{2}, y, z+\frac{1}{2}; & \frac{1}{2}-x, \bar{y}, z+\frac{1}{2}; & x+\frac{2}{2}, \frac{1}{2}-y, z+\frac{2}{2}; & \\ & & & \frac{2}{2}-x, y+\frac{1}{2}, z+\frac{2}{2}; \\ x, y+\frac{1}{2}, z+\frac{1}{2}; & \bar{x}, \frac{1}{2}-y, z+\frac{1}{2}; & x+\frac{1}{2}, \frac{2}{2}-y, z+\frac{2}{2}; & \\ & & & \frac{1}{2}-x, y+\frac{2}{2}, z+\frac{2}{2}. \end{array}$$

SPACE-GROUP  $C_{2v}^{20}$ .*Two* equivalent positions:

(a)  $00u$ ;  $\frac{1}{2}, \frac{1}{2}, u+\frac{1}{2}$ .      (b)  $\frac{1}{2}0u$ ;  $0, \frac{1}{2}, u+\frac{1}{2}$ .

*Four* equivalent positions:

(c)  $u0v$ ;  $\bar{u}0v$ ;  $u+\frac{1}{2}, \frac{1}{2}, v+\frac{1}{2}$ ;  $\frac{1}{2}-u, \frac{1}{2}, v+\frac{1}{2}$ .  
(d)  $0uv$ ;  $0\bar{u}v$ ;  $\frac{1}{2}, u+\frac{1}{2}, v+\frac{1}{2}$ ;  $\frac{1}{2}, \frac{1}{2}-u, v+\frac{1}{2}$ .

*Eight* equivalent positions:

(e)  $xyz$ ;       $\bar{x}\bar{y}z$ ;       $x\bar{y}z$ ;       $\bar{x}yz$ ;  
 $x+\frac{1}{2}, y+\frac{1}{2}, z+\frac{1}{2}$ ;       $\frac{1}{2}-x, \frac{1}{2}-y, z+\frac{1}{2}$ ;       $x+\frac{1}{2}, \frac{1}{2}-y, z+\frac{1}{2}$ ;  
 $\frac{1}{2}-x, y+\frac{1}{2}, z+\frac{1}{2}$ .

SPACE-GROUP  $C_{2v}^{21}$ .*Four* equivalent positions:

(a)  $00u$ ;  $\frac{1}{2}\frac{1}{2}u$ ;  $0, 0, u+\frac{1}{2}$ ;  $\frac{1}{2}, \frac{1}{2}, u+\frac{1}{2}$ .  
(b)  $0\frac{1}{2}u$ ;  $\frac{1}{2}0u$ ;  $0, \frac{1}{2}, u+\frac{1}{2}$ ;  $\frac{1}{2}, 0, u+\frac{1}{2}$ .

*Eight* equivalent positions:

(c)  $xyz$ ;       $\bar{x}\bar{y}z$ ;       $x, \bar{y}, z+\frac{1}{2}$ ;       $\bar{x}, y, z+\frac{1}{2}$ ;  
 $x+\frac{1}{2}, y+\frac{1}{2}, z+\frac{1}{2}$ ;       $\frac{1}{2}-x, \frac{1}{2}-y, z+\frac{1}{2}$ ;       $x+\frac{1}{2}, \frac{1}{2}-y, z$ ;  
 $\frac{1}{2}-x, y+\frac{1}{2}, z$ .

SPACE-GROUP  $C_{2v}^{22}$ .*Four* equivalent positions:

(a)  $00u$ ;  $\frac{1}{2}0u$ ;  $\frac{1}{2}, \frac{1}{2}, u+\frac{1}{2}$ ;       $0, \frac{1}{2}, u+\frac{1}{2}$ ;  
(b)  $\frac{1}{2}uv$ ;  $\frac{1}{2}\bar{u}v$ ;  $\frac{1}{2}, u+\frac{1}{2}, v+\frac{1}{2}$ ;       $\frac{1}{2}, \frac{1}{2}-u, v+\frac{1}{2}$ .

*Eight* equivalent positions:

(c)  $xyz$ ;       $\bar{x}\bar{y}z$ ;       $x+\frac{1}{2}, \bar{y}, z$ ;       $\frac{1}{2}-x, y, z$ ;  
 $x+\frac{1}{2}, y+\frac{1}{2}, z+\frac{1}{2}$ ;       $\frac{1}{2}-x, \frac{1}{2}-y, z+\frac{1}{2}$ ;       $x, \frac{1}{2}-y, z+\frac{1}{2}$ ;  
 $\bar{x}, y+\frac{1}{2}, z+\frac{1}{2}$ .

## B. HEMIHEDRY.

SPACE-GROUP  $V^1$ .*One* equivalent position:

(a)  $000$ .      (d)  $00\frac{1}{2}$ .      (g)  $0\frac{1}{2}\frac{1}{2}$ .  
(b)  $\frac{1}{2}00$ .      (e)  $\frac{1}{2}\frac{1}{2}0$ .      (h)  $\frac{1}{2}\frac{1}{2}\frac{1}{2}$ .  
(c)  $0\frac{1}{2}0$ .      (f)  $\frac{1}{2}0\frac{1}{2}$ .

*Two* equivalent positions:

(i)  $u00$ ;  $\bar{u}00$ .      (m)  $0u0$ ;  $0\bar{u}0$ .      (q)  $00u$ ;  $00\bar{u}$ .  
(j)  $u0\frac{1}{2}$ ;  $\bar{u}0\frac{1}{2}$ .      (n)  $0u\frac{1}{2}$ ;  $0\bar{u}\frac{1}{2}$ .      (r)  $\frac{1}{2}0u$ ;  $\frac{1}{2}0\bar{u}$ .  
(k)  $u\frac{1}{2}0$ ;  $\bar{u}\frac{1}{2}0$ .      (o)  $\frac{1}{2}u0$ ;  $\frac{1}{2}\bar{u}0$ .      (s)  $0\frac{1}{2}u$ ;  $0\frac{1}{2}\bar{u}$ .  
(l)  $u\frac{1}{2}\frac{1}{2}$ ;  $\bar{u}\frac{1}{2}\frac{1}{2}$ .      (p)  $\frac{1}{2}u\frac{1}{2}$ ;  $\frac{1}{2}\bar{u}\frac{1}{2}$ .      (t)  $\frac{1}{2}\frac{1}{2}u$ ;  $\frac{1}{2}\frac{1}{2}\bar{u}$ .

*Four* equivalent positions:

(u)  $xyz$ ;  $x\bar{y}z$ ;  $\bar{x}yz$ ;  $\bar{x}\bar{y}z$ .

SPACE-GROUP  $V^2$ .

*Two equivalent positions:*

- (a)  $u\ 0\ 0$ ;  $\bar{u}\ 0\ \frac{1}{2}$ .                      (c)  $0\ u\ \frac{1}{2}$ ;  $0\ \bar{u}\ \frac{1}{2}$ .  
 (b)  $u\ \frac{1}{2}\ \frac{1}{2}$ ;  $\bar{u}\ \frac{1}{2}\ 0$ .                      (d)  $\frac{1}{2}\ u\ \frac{1}{2}$ ;  $\frac{1}{2}\ \bar{u}\ \frac{1}{2}$ .

*Four equivalent positions:*

- (e)  $xyz$ ;  $x\bar{y}\bar{z}$ ;  $\bar{x}, y, \frac{1}{2}-z$ ;  $\bar{x}, \bar{y}, z+\frac{1}{2}$ .

SPACE-GROUP  $V^3$ .

*Two equivalent positions:*

- (a)  $0\ 0\ u$ ;  $\frac{1}{2}\ \frac{1}{2}\ \bar{u}$ .                      (b)  $0\ \frac{1}{2}\ u$ ;  $\frac{1}{2}\ 0\ \bar{u}$ .

*Four equivalent positions:*

- (c)  $xyz$ ;  $x+\frac{1}{2}, \frac{1}{2}-y, \bar{z}$ ;  $\frac{1}{2}-x, y+\frac{1}{2}, \bar{z}$ ;  $\bar{x}\bar{y}z$ .

SPACE-GROUP  $V^4$ .

*Four equivalent positions:*

- (a)  $xyz$ ;  $x+\frac{1}{2}, \frac{1}{2}-y, \bar{z}$ ;  $\bar{x}, y+\frac{1}{2}, \frac{1}{2}-z$ ;  $\frac{1}{2}-x, \bar{y}, z+\frac{1}{2}$ .

SPACE-GROUP  $V^5$ .

*Four equivalent positions:*

- (a)  $u\ 0\ 0$ ;  $\bar{u}\ 0\ \frac{1}{2}$ ;  $u+\frac{1}{2}, \frac{1}{2}, 0$ ;  $\frac{1}{2}-u, \frac{1}{2}, \frac{1}{2}$ .  
 (b)  $0\ u\ \frac{1}{2}$ ;  $0\ \bar{u}\ \frac{1}{2}$ ;  $\frac{1}{2}, u+\frac{1}{2}, \frac{1}{2}$ ;  $\frac{1}{2}, \frac{1}{2}-u, \frac{1}{2}$ .

*Eight equivalent positions:*

- (c)  $xyz$ ;                       $x\bar{y}\bar{z}$ ;                       $\bar{x}, y, \frac{1}{2}-z$ ;                       $\bar{x}, \bar{y}, z+\frac{1}{2}$ ;  
 $x+\frac{1}{2}, y+\frac{1}{2}, z$ ;  $x+\frac{1}{2}, \frac{1}{2}-y, \bar{z}$ ;  $\frac{1}{2}-x, y+\frac{1}{2}, \frac{1}{2}-z$ ;  
 $\frac{1}{2}-x, \frac{1}{2}-y, z+\frac{1}{2}$ .

SPACE-GROUP  $V^6$ .

*Two equivalent positions:*

- (a)  $0\ 0\ 0$ ;  $\frac{1}{2}\ \frac{1}{2}\ 0$ .                      (c)  $0\ \frac{1}{2}\ \frac{1}{2}$ ;  $\frac{1}{2}\ 0\ \frac{1}{2}$ .  
 (b)  $\frac{1}{2}\ 0\ 0$ ;  $0\ \frac{1}{2}\ 0$ .                      (d)  $\frac{1}{2}\ \frac{1}{2}\ \frac{1}{2}$ ;  $0\ 0\ \frac{1}{2}$ .

*Four equivalent positions:*

- (e)  $u\ 0\ 0$ ;  $\bar{u}\ 0\ 0$ ;  $u+\frac{1}{2}, \frac{1}{2}, 0$ ;  $\frac{1}{2}-u, \frac{1}{2}, 0$ .  
 (f)  $u\ \frac{1}{2}\ \frac{1}{2}$ ;  $\bar{u}\ \frac{1}{2}\ \frac{1}{2}$ ;  $u+\frac{1}{2}, 0, \frac{1}{2}$ ;  $\frac{1}{2}-u, 0, \frac{1}{2}$ .  
 (g)  $0\ u\ 0$ ;  $0\ \bar{u}\ 0$ ;  $\frac{1}{2}, u+\frac{1}{2}, 0$ ;  $\frac{1}{2}, \frac{1}{2}-u, 0$ .  
 (h)  $\frac{1}{2}\ u\ \frac{1}{2}$ ;  $\frac{1}{2}\ \bar{u}\ \frac{1}{2}$ ;  $0, u+\frac{1}{2}, \frac{1}{2}$ ;  $0, \frac{1}{2}-u, \frac{1}{2}$ .  
 (i)  $0\ 0\ u$ ;  $0\ 0\ \bar{u}$ ;  $\frac{1}{2}\ \frac{1}{2}\ u$ ;  $\frac{1}{2}\ \frac{1}{2}\ \bar{u}$ .  
 (j)  $0\ \frac{1}{2}\ u$ ;  $0\ \frac{1}{2}\ \bar{u}$ ;  $\frac{1}{2}\ 0\ u$ ;  $\frac{1}{2}\ 0\ \bar{u}$ .  
 (k)  $\frac{1}{2}\ \frac{1}{2}\ u$ ;  $\frac{1}{2}\ \frac{1}{2}\ \bar{u}$ ;  $\frac{1}{2}\ \frac{1}{2}\ \bar{u}$ ;  $\frac{1}{2}\ \frac{1}{2}\ u$ .

*Eight equivalent positions:*

- (l)  $xyz$ ;                       $x\bar{y}\bar{z}$ ;                       $\bar{x}y\bar{z}$ ;                       $\bar{x}\bar{y}z$ ;  
 $x+\frac{1}{2}, y+\frac{1}{2}, z$ ;  $x+\frac{1}{2}, \frac{1}{2}-y, \bar{z}$ ;  $\frac{1}{2}-x, y+\frac{1}{2}, \bar{z}$ ;  $\frac{1}{2}-x, \frac{1}{2}-y, z$ .

SPACE-GROUP  $V^7$ .*Four equivalent positions:*

- (a)  $000$ ;  $\frac{1}{2}\frac{1}{2}0$ ;  $\frac{1}{2}0\frac{1}{2}$ ;  $0\frac{1}{2}\frac{1}{2}$ .  
 (b)  $\frac{1}{2}00$ ;  $0\frac{1}{2}0$ ;  $00\frac{1}{2}$ ;  $\frac{1}{2}\frac{1}{2}\frac{1}{2}$ .  
 (c)  $\frac{1}{2}\frac{1}{2}\frac{1}{2}$ ;  $\frac{1}{2}\frac{1}{2}\frac{1}{2}$ ;  $\frac{1}{2}\frac{1}{2}\frac{1}{2}$ ;  $\frac{1}{2}\frac{1}{2}\frac{1}{2}$ .  
 (d)  $\frac{1}{2}\frac{1}{2}\frac{1}{2}$ ;  $\frac{1}{2}\frac{1}{2}\frac{1}{2}$ ;  $\frac{1}{2}\frac{1}{2}\frac{1}{2}$ ;  $\frac{1}{2}\frac{1}{2}\frac{1}{2}$ .

*Eight equivalent positions:*

- (e)  $u00$ ;  $\bar{u}00$ ;  $u+\frac{1}{2}, \frac{1}{2}, 0$ ;  $\frac{1}{2}-u, \frac{1}{2}, 0$ ;  
 $u\frac{1}{2}\frac{1}{2}$ ;  $\bar{u}\frac{1}{2}\frac{1}{2}$ ;  $u+\frac{1}{2}, 0, \frac{1}{2}$ ;  $\frac{1}{2}-u, 0, \frac{1}{2}$ .  
 (f)  $0u0$ ;  $0\bar{u}0$ ;  $\frac{1}{2}, u+\frac{1}{2}, 0$ ;  $\frac{1}{2}, \frac{1}{2}-u, 0$ ;  
 $\frac{1}{2}u\frac{1}{2}$ ;  $\frac{1}{2}\bar{u}\frac{1}{2}$ ;  $0, u+\frac{1}{2}, \frac{1}{2}$ ;  $0, \frac{1}{2}-u, \frac{1}{2}$ .  
 (g)  $00u$ ;  $00\bar{u}$ ;  $\frac{1}{2}, 0, u+\frac{1}{2}$ ;  $\frac{1}{2}, 0, \frac{1}{2}-u$ ;  
 $\frac{1}{2}\frac{1}{2}u$ ;  $\frac{1}{2}\frac{1}{2}\bar{u}$ ;  $0, \frac{1}{2}, u+\frac{1}{2}$ ;  $0, \frac{1}{2}, \frac{1}{2}-u$ .  
 (h)  $\frac{1}{2}\frac{1}{2}u$ ;  $\frac{1}{2}\frac{1}{2}\bar{u}$ ;  $\frac{1}{2}, \frac{1}{2}, \frac{1}{2}-u$ ;  $\frac{1}{2}, \frac{1}{2}, \frac{1}{2}-u$ ;  
 $\frac{1}{2}\frac{1}{2}\bar{u}$ ;  $\frac{1}{2}\frac{1}{2}u$ ;  $\frac{1}{2}, \frac{1}{2}, u+\frac{1}{2}$ ;  $\frac{1}{2}, \frac{1}{2}, u+\frac{1}{2}$ .  
 (i)  $\frac{1}{2}u\frac{1}{2}$ ;  $\frac{1}{2}\bar{u}\frac{1}{2}$ ;  $\frac{1}{2}, \frac{1}{2}-u, \frac{1}{2}$ ;  $\frac{1}{2}, \frac{1}{2}-u, \frac{1}{2}$ ;  
 $\frac{1}{2}\bar{u}\frac{1}{2}$ ;  $\frac{1}{2}u\frac{1}{2}$ ;  $\frac{1}{2}, u+\frac{1}{2}, \frac{1}{2}$ ;  $\frac{1}{2}, u+\frac{1}{2}, \frac{1}{2}$ .  
 (j)  $u\frac{1}{2}\frac{1}{2}$ ;  $u\frac{1}{2}\frac{1}{2}$ ;  $\frac{1}{2}-u, \frac{1}{2}, \frac{1}{2}$ ;  $\frac{1}{2}-u, \frac{1}{2}, \frac{1}{2}$ ;  
 $\bar{u}\frac{1}{2}\frac{1}{2}$ ;  $\bar{u}\frac{1}{2}\frac{1}{2}$ ;  $u+\frac{1}{2}, \frac{1}{2}, \frac{1}{2}$ ;  $u+\frac{1}{2}, \frac{1}{2}, \frac{1}{2}$ .

*Sixteen equivalent positions:*

- (k)  $xyz$ ;  $x\bar{y}\bar{z}$ ;  $\bar{x}yz$ ;  $\bar{x}\bar{y}z$ ;  
 $x+\frac{1}{2}, y+\frac{1}{2}, z$ ;  $x+\frac{1}{2}, \frac{1}{2}-y, \bar{z}$ ;  $\frac{1}{2}-x, y+\frac{1}{2}, \bar{z}$ ;  $\frac{1}{2}-x, \frac{1}{2}-y, z$ ;  
 $x+\frac{1}{2}, y, z+\frac{1}{2}$ ;  $x+\frac{1}{2}, \bar{y}, \frac{1}{2}-z$ ;  $\frac{1}{2}-x, y, \frac{1}{2}-z$ ;  $\frac{1}{2}-x, \bar{y}, z+\frac{1}{2}$ ;  
 $x, y+\frac{1}{2}, z+\frac{1}{2}$ ;  $x, \frac{1}{2}-y, \frac{1}{2}-z$ ;  $\bar{x}, y+\frac{1}{2}, \frac{1}{2}-z$ ;  $\bar{x}, \frac{1}{2}-y, z+\frac{1}{2}$ .

SPACE-GROUP  $V^8$ .*Two equivalent positions:*

- (a)  $000$ ;  $\frac{1}{2}\frac{1}{2}\frac{1}{2}$ . (c)  $00\frac{1}{2}$ ;  $\frac{1}{2}\frac{1}{2}0$ .  
 (b)  $\frac{1}{2}00$ ;  $0\frac{1}{2}\frac{1}{2}$ . (d)  $\frac{1}{2}0\frac{1}{2}$ ;  $0\frac{1}{2}0$ .

*Four equivalent positions:*

- (e)  $u00$ ;  $\bar{u}00$ ;  $u+\frac{1}{2}, \frac{1}{2}, \frac{1}{2}$ ;  $\frac{1}{2}-u, \frac{1}{2}, \frac{1}{2}$ .  
 (f)  $u0\frac{1}{2}$ ;  $\bar{u}0\frac{1}{2}$ ;  $u+\frac{1}{2}, \frac{1}{2}, 0$ ;  $\frac{1}{2}-u, \frac{1}{2}, 0$ .  
 (g)  $0u0$ ;  $0\bar{u}0$ ;  $\frac{1}{2}, u+\frac{1}{2}, \frac{1}{2}$ ;  $\frac{1}{2}, \frac{1}{2}-u, \frac{1}{2}$ .  
 (h)  $0u\frac{1}{2}$ ;  $0\bar{u}\frac{1}{2}$ ;  $\frac{1}{2}, u+\frac{1}{2}, 0$ ;  $\frac{1}{2}, \frac{1}{2}-u, 0$ .  
 (i)  $00u$ ;  $00\bar{u}$ ;  $\frac{1}{2}, \frac{1}{2}, u+\frac{1}{2}$ ;  $\frac{1}{2}, \frac{1}{2}, \frac{1}{2}-u$ .  
 (j)  $0\frac{1}{2}u$ ;  $0\frac{1}{2}\bar{u}$ ;  $\frac{1}{2}, 0, u+\frac{1}{2}$ ;  $\frac{1}{2}, 0, \frac{1}{2}-u$ .

*Eight equivalent positions:*

- (k)  $xyz$ ;  $x\bar{y}\bar{z}$ ;  $\bar{x}yz$ ;  $\bar{x}\bar{y}z$ ;  
 $x+\frac{1}{2}, y+\frac{1}{2}, z+\frac{1}{2}$ ;  $x+\frac{1}{2}, \frac{1}{2}-y, \frac{1}{2}-z$ ;  $\frac{1}{2}-x, y+\frac{1}{2}, \frac{1}{2}-z$ ;  
 $\frac{1}{2}-x, \frac{1}{2}-y, z+\frac{1}{2}$ .

SPACE-GROUP  $V^0$ .

Four equivalent positions:

- (a)  $u\ 0\ \frac{1}{2}$ ;  $\frac{1}{2}-u, 0, \frac{1}{2}$ ;  $\bar{u}\ \frac{1}{2}\ \frac{1}{2}$ ;  $u+\frac{1}{2}, \frac{1}{2}, \frac{1}{2}$ .  
 (b)  $\frac{1}{2}u\ 0$ ;  $\frac{1}{2}, \frac{1}{2}-u, 0$ ;  $\frac{1}{2}\bar{u}\ \frac{1}{2}$ ;  $\frac{1}{2}, u+\frac{1}{2}, \frac{1}{2}$ .  
 (c)  $0\ \frac{1}{2}u$ ;  $0, \frac{1}{2}, \frac{1}{2}-u$ ;  $\frac{1}{2}\ \frac{1}{2}\bar{u}$ ;  $\frac{1}{2}, \frac{1}{2}, u+\frac{1}{2}$ .

Eight equivalent positions:

- (d)  $xyz$ ;  $x, \bar{y}, \frac{1}{2}-z$ ;  $\frac{1}{2}-x, y, \bar{z}$ ;  $\bar{x}, \frac{1}{2}-y, z$ ;  
 $x+\frac{1}{2}, y+\frac{1}{2}, z+\frac{1}{2}$ ;  $x+\frac{1}{2}, \frac{1}{2}-y, \bar{z}$ ;  $\bar{x}, y+\frac{1}{2}, \frac{1}{2}-z$ ;  $\frac{1}{2}-x, \bar{y}, z+\frac{1}{2}$ ;

C. HOLOHEDRY.

SPACE-GROUP  $V_h^1$ .

One equivalent position:

- (a)  $0\ 0\ 0$ . (d)  $\frac{1}{2}\ 0\ \frac{1}{2}$ . (g)  $0\ \frac{1}{2}\ \frac{1}{2}$ .  
 (b)  $\frac{1}{2}\ 0\ 0$ . (e)  $0\ \frac{1}{2}\ 0$ . (h)  $\frac{1}{2}\ \frac{1}{2}\ \frac{1}{2}$ .  
 (c)  $0\ 0\ \frac{1}{2}$ . (f)  $\frac{1}{2}\ \frac{1}{2}\ 0$ .

Two equivalent positions:

- (i)  $u\ 0\ 0$ ;  $\bar{u}\ 0\ 0$ . (m)  $0\ u\ 0$ ;  $0\ \bar{u}\ 0$ . (q)  $0\ 0\ u$ ;  $0\ 0\ \bar{u}$ .  
 (j)  $u\ 0\ \frac{1}{2}$ ;  $\bar{u}\ 0\ \frac{1}{2}$ . (n)  $0\ u\ \frac{1}{2}$ ;  $0\ \bar{u}\ \frac{1}{2}$ . (r)  $0\ \frac{1}{2}\ u$ ;  $0\ \frac{1}{2}\ \bar{u}$ .  
 (k)  $u\ \frac{1}{2}\ 0$ ;  $\bar{u}\ \frac{1}{2}\ 0$ . (o)  $\frac{1}{2}\ u\ 0$ ;  $\frac{1}{2}\ \bar{u}\ 0$ . (s)  $\frac{1}{2}\ 0\ u$ ;  $\frac{1}{2}\ 0\ \bar{u}$ .  
 (l)  $u\ \frac{1}{2}\ \frac{1}{2}$ ;  $\bar{u}\ \frac{1}{2}\ \frac{1}{2}$ . (p)  $\frac{1}{2}\ u\ \frac{1}{2}$ ;  $\frac{1}{2}\ \bar{u}\ \frac{1}{2}$ . (t)  $\frac{1}{2}\ \frac{1}{2}\ u$ ;  $\frac{1}{2}\ \frac{1}{2}\ \bar{u}$ .

Four equivalent positions:

- (u)  $0\ u\ v$ ;  $0\ \bar{u}\ \bar{v}$ ;  $0\ u\ \bar{v}$ ;  $0\ \bar{u}\ v$ .  
 (v)  $\frac{1}{2}\ u\ v$ ;  $\frac{1}{2}\ \bar{u}\ \bar{v}$ ;  $\frac{1}{2}\ u\ \bar{v}$ ;  $\frac{1}{2}\ \bar{u}\ v$ .  
 (w)  $u\ 0\ v$ ;  $u\ 0\ \bar{v}$ ;  $\bar{u}\ 0\ \bar{v}$ ;  $\bar{u}\ 0\ v$ .  
 (x)  $u\ \frac{1}{2}\ v$ ;  $u\ \frac{1}{2}\ \bar{v}$ ;  $\bar{u}\ \frac{1}{2}\ \bar{v}$ ;  $\bar{u}\ \frac{1}{2}\ v$ .  
 (y)  $u\ v\ 0$ ;  $u\ \bar{v}\ 0$ ;  $\bar{u}\ v\ 0$ ;  $\bar{u}\ \bar{v}\ 0$ .  
 (z)  $u\ v\ \frac{1}{2}$ ;  $u\ \bar{v}\ \frac{1}{2}$ ;  $\bar{u}\ v\ \frac{1}{2}$ ;  $u\ \bar{v}\ \frac{1}{2}$ .

Eight equivalent positions:

- (α)  $xyz$ ;  $x\bar{y}\bar{z}$ ;  $\bar{x}y\bar{z}$ ;  $\bar{x}\bar{y}z$ ;  $x\bar{y}z$ ;  $\bar{x}yz$ ;  $x\bar{y}z$ ;  $xy\bar{z}$ .

SPACE-GROUP  $V_h^2$ .

Two equivalent positions:

- (a)  $0\ 0\ 0$ ;  $\frac{1}{2}\ \frac{1}{2}\ \frac{1}{2}$ . (c)  $0\ 0\ \frac{1}{2}$ ;  $\frac{1}{2}\ \frac{1}{2}\ 0$ .  
 (b)  $\frac{1}{2}\ 0\ 0$ ;  $0\ \frac{1}{2}\ \frac{1}{2}$ . (d)  $\frac{1}{2}\ 0\ \frac{1}{2}$ ;  $0\ \frac{1}{2}\ 0$ .

Four equivalent positions:

- (e)  $\frac{1}{2}\ \frac{1}{2}\ \frac{1}{2}$ ;  $\frac{1}{2}\ \frac{1}{2}\ \frac{1}{2}$ ;  $\frac{1}{2}\ \frac{1}{2}\ \frac{1}{2}$ ;  $\frac{1}{2}\ \frac{1}{2}\ \frac{1}{2}$ .  
 (f)  $\frac{1}{2}\ \frac{1}{2}\ \frac{1}{2}$ ;  $\frac{1}{2}\ \frac{1}{2}\ \frac{1}{2}$ ;  $\frac{1}{2}\ \frac{1}{2}\ \frac{1}{2}$ ;  $\frac{1}{2}\ \frac{1}{2}\ \frac{1}{2}$ .  
 (g)  $u\ 0\ 0$ ;  $\bar{u}\ 0\ 0$ ;  $\frac{1}{2}-u, \frac{1}{2}, \frac{1}{2}$ ;  $u+\frac{1}{2}, \frac{1}{2}, \frac{1}{2}$ .  
 (h)  $u\ 0\ \frac{1}{2}$ ;  $\bar{u}\ 0\ \frac{1}{2}$ ;  $\frac{1}{2}-u, \frac{1}{2}, 0$ ;  $u+\frac{1}{2}, \frac{1}{2}, 0$ .  
 (i)  $0\ u\ 0$ ;  $0\ \bar{u}\ 0$ ;  $\frac{1}{2}, \frac{1}{2}-u, \frac{1}{2}$ ;  $\frac{1}{2}, u+\frac{1}{2}, \frac{1}{2}$ .  
 (j)  $0\ u\ \frac{1}{2}$ ;  $0\ \bar{u}\ \frac{1}{2}$ ;  $\frac{1}{2}, \frac{1}{2}-u, 0$ ;  $\frac{1}{2}, u+\frac{1}{2}, 0$ .  
 (k)  $0\ 0\ u$ ;  $0\ 0\ \bar{u}$ ;  $\frac{1}{2}, \frac{1}{2}, \frac{1}{2}-u$ ;  $\frac{1}{2}, \frac{1}{2}, u+\frac{1}{2}$ .  
 (l)  $0\ \frac{1}{2}\ u$ ;  $0\ \frac{1}{2}\ \bar{u}$ ;  $\frac{1}{2}, 0, \frac{1}{2}-u$ ;  $\frac{1}{2}, 0, u+\frac{1}{2}$ .



SPACE-GROUP  $V_1^2$  (continued).

Eight equivalent positions:

$$\begin{aligned} (m) \ x y z; \quad x \bar{y} \bar{z}; \quad \bar{x} y \bar{z}; \quad \bar{x} \bar{y} z; \\ \frac{1}{2}-x, \frac{1}{2}-y, \frac{1}{2}-z; \quad \frac{1}{2}-x, y+\frac{1}{2}, z+\frac{1}{2}; \quad x+\frac{1}{2}, \frac{1}{2}-y, z+\frac{1}{2}; \\ x+\frac{1}{2}, y+\frac{1}{2}, \frac{1}{2}-z. \end{aligned}$$

SPACE-GROUP  $V_1^3$ .

Two equivalent positions:

$$\begin{aligned} (a) \ 00\frac{1}{2}; \ 00\frac{2}{2}. \quad (e) \ 000; \ 00\frac{1}{2}. \\ (b) \ \frac{1}{2}\frac{1}{2}\frac{1}{2}; \ \frac{1}{2}\frac{1}{2}\frac{2}{2}. \quad (f) \ \frac{1}{2}00 \ \frac{1}{2}0\frac{1}{2}. \\ (c) \ 0\frac{1}{2}\frac{1}{2}; \ 0\frac{1}{2}\frac{2}{2}. \quad (g) \ 0\frac{1}{2}\frac{1}{2}; \ 0\frac{1}{2}0. \\ (d) \ \frac{1}{2}0\frac{1}{2}; \ \frac{1}{2}0\frac{2}{2}. \quad (h) \ \frac{1}{2}\frac{1}{2}\frac{1}{2}; \ \frac{1}{2}\frac{1}{2}0. \end{aligned}$$

Four equivalent positions:

$$\begin{aligned} (i) \ u00; \ \bar{u}00; \ u0\frac{1}{2}; \ u0\frac{1}{2}. \\ (j) \ u\frac{1}{2}\frac{1}{2}; \ \bar{u}\frac{1}{2}\frac{1}{2}; \ u\frac{1}{2}0; \ u\frac{1}{2}0. \\ (k) \ 0u0; \ 0\bar{u}0; \ 0u\frac{1}{2}; \ 0u\frac{1}{2}. \\ (l) \ \frac{1}{2}u\frac{1}{2}; \ \frac{1}{2}\bar{u}\frac{1}{2}; \ \frac{1}{2}\bar{u}0; \ \frac{1}{2}u0. \\ (m) \ 00u; \ 00\bar{u}; \ 0, 0, \frac{1}{2}-u; \ 0, 0, u+\frac{1}{2}. \\ (n) \ \frac{1}{2}\frac{1}{2}u; \ \frac{1}{2}\frac{1}{2}\bar{u}; \ \frac{1}{2}, \frac{1}{2}, \frac{1}{2}-u; \ \frac{1}{2}, \frac{1}{2}, u+\frac{1}{2}. \\ (o) \ 0\frac{1}{2}u; \ 0\frac{1}{2}\bar{u}; \ 0, \frac{1}{2}, \frac{1}{2}-u; \ 0, \frac{1}{2}, u+\frac{1}{2}. \\ (p) \ \frac{1}{2}0u; \ \frac{1}{2}0\bar{u}; \ \frac{1}{2}, 0, \frac{1}{2}-u; \ \frac{1}{2}, 0, u+\frac{1}{2}. \\ (q) \ uv\frac{1}{2}; \ u\bar{v}\frac{1}{2}; \ \bar{u}v\frac{1}{2}; \ \bar{u}\bar{v}\frac{1}{2}. \end{aligned}$$

Eight equivalent positions:

$$\begin{aligned} (r) \ x y z; \quad x \bar{y} \bar{z}; \quad \bar{x} y \bar{z}; \quad \bar{x} \bar{y} z; \\ \bar{x} \bar{y}, \frac{1}{2}-z; \quad \bar{x}, y, z+\frac{1}{2}; \quad x, \bar{y}, z+\frac{1}{2}; \quad x, y, \frac{1}{2}-z. \end{aligned}$$

SPACE-GROUP  $V_1^4$ .

Two equivalent positions:

$$\begin{aligned} (a) \ 000; \ \frac{1}{2}\frac{1}{2}0. \quad (c) \ 0\frac{1}{2}\frac{1}{2}; \ \frac{1}{2}0\frac{1}{2}. \\ (b) \ \frac{1}{2}00; \ 0\frac{1}{2}0. \quad (d) \ \frac{1}{2}\frac{1}{2}\frac{1}{2}; \ 00\frac{1}{2}. \end{aligned}$$

Four equivalent positions:

$$\begin{aligned} (e) \ \frac{1}{2}\frac{1}{2}0; \ \frac{1}{2}\frac{2}{2}0; \ \frac{2}{2}\frac{1}{2}0; \ \frac{2}{2}\frac{2}{2}0. \\ (f) \ \frac{1}{2}\frac{1}{2}\frac{1}{2}; \ \frac{1}{2}\frac{2}{2}\frac{1}{2}; \ \frac{2}{2}\frac{1}{2}\frac{1}{2}; \ \frac{2}{2}\frac{2}{2}\frac{1}{2}. \\ (g) \ u00; \ \bar{u}00; \ \frac{1}{2}-u, \frac{1}{2}, 0; \ u+\frac{1}{2}, \frac{1}{2}, 0. \\ (h) \ u\frac{1}{2}\frac{1}{2}; \ \bar{u}\frac{1}{2}\frac{1}{2}; \ \frac{1}{2}-u, 0, \frac{1}{2}; \ u+\frac{1}{2}, 0, \frac{1}{2}. \\ (i) \ 0u0; \ 0\bar{u}0; \ \frac{1}{2}, \frac{1}{2}-u, 0; \ \frac{1}{2}, u+\frac{1}{2}, 0. \\ (j) \ \frac{1}{2}u\frac{1}{2}; \ \frac{1}{2}\bar{u}\frac{1}{2}; \ 0, \frac{1}{2}-u, \frac{1}{2}; \ 0, u+\frac{1}{2}, \frac{1}{2}. \\ (k) \ 00u; \ 00\bar{u}; \ \frac{1}{2}\frac{1}{2}\bar{u}; \ \frac{1}{2}\frac{1}{2}u. \\ (l) \ 0\frac{1}{2}u; \ 0\frac{1}{2}\bar{u}; \ \frac{1}{2}0\bar{u}; \ \frac{1}{2}0u. \end{aligned}$$

Eight equivalent positions:

$$\begin{aligned} (m) \ x y z; \quad x \bar{y} \bar{z}; \quad \bar{x} y \bar{z}; \quad \bar{x} \bar{y} z; \\ \frac{1}{2}-x, \frac{1}{2}-y, \bar{z}; \quad \frac{1}{2}-x, y+\frac{1}{2}, z; \quad x+\frac{1}{2}, \frac{1}{2}-y, z; \quad x+\frac{1}{2}, y+\frac{1}{2}, \bar{z}. \end{aligned}$$

SPACE-GROUP  $V_n^6$ .

Two equivalent positions:

- (a)  $000$ ;  $00\frac{1}{2}$ . (d)  $\frac{1}{2}\frac{1}{2}\frac{1}{2}$ ;  $\frac{1}{2}\frac{1}{2}0$ .  
 (b)  $\frac{1}{2}00$ ;  $\frac{1}{2}0\frac{1}{2}$ . (e)  $0u\frac{1}{2}$ ;  $0\bar{u}\frac{1}{2}$ .  
 (c)  $0\frac{1}{2}\frac{1}{2}$ ;  $0\frac{1}{2}0$ . (f)  $\frac{1}{2}u\frac{1}{2}$ ;  $\frac{1}{2}\bar{u}\frac{1}{2}$ .

Four equivalent positions:

- (g)  $u00$ ;  $\bar{u}00$ ;  $\bar{u}0\frac{1}{2}$ ;  $u0\frac{1}{2}$ .  
 (h)  $u\frac{1}{2}\frac{1}{2}$ ;  $\bar{u}\frac{1}{2}\frac{1}{2}$ ;  $\bar{u}\frac{1}{2}0$ ;  $u\frac{1}{2}0$ .  
 (i)  $0uv$ ;  $0\bar{u}\bar{v}$ ;  $0, u, \frac{1}{2}-v$ ;  $0, \bar{u}, v+\frac{1}{2}$ .  
 (j)  $\frac{1}{2}uv$ ;  $\frac{1}{2}\bar{u}\bar{v}$ ;  $\frac{1}{2}, u, \frac{1}{2}-v$ ;  $\frac{1}{2}, \bar{u}, v+\frac{1}{2}$ .  
 (k)  $uv\frac{1}{2}$ ;  $u\bar{v}\frac{1}{2}$ ;  $\bar{u}v\frac{1}{2}$ ;  $\bar{u}\bar{v}\frac{1}{2}$ .

Eight equivalent positions:

- (l)  $xyz$ ;  $x\bar{y}\bar{z}$ ;  $\bar{x}, y, \frac{1}{2}-z$ ;  $\bar{x}, \bar{y}, z+\frac{1}{2}$ .  
 $\bar{x}\bar{y}\bar{z}$ ;  $\bar{x}yz$ ;  $x, \bar{y}, z+\frac{1}{2}$ ;  $x, y, \frac{1}{2}-z$ .

 SPACE-GROUP  $V_n^6$ .

Four equivalent positions:

- (a)  $\frac{1}{2}\frac{1}{2}0$ ;  $\frac{1}{2}\frac{1}{2}\frac{1}{2}$ ;  $\frac{1}{2}\frac{1}{2}\frac{1}{2}$ ;  $\frac{1}{2}\frac{1}{2}\frac{1}{2}$ .  
 (b)  $\frac{1}{2}\frac{1}{2}\frac{1}{2}$ ;  $\frac{1}{2}\frac{1}{2}\frac{1}{2}$ ;  $\frac{1}{2}\frac{1}{2}0$ ;  $\frac{1}{2}\frac{1}{2}0$ .  
 (c)  $u00$ ;  $\bar{u}0\frac{1}{2}$ ;  $\frac{1}{2}-u, \frac{1}{2}, 0$ ;  $u+\frac{1}{2}, \frac{1}{2}, \frac{1}{2}$ .  
 (d)  $0u\frac{1}{2}$ ;  $0\bar{u}\frac{1}{2}$ ;  $\frac{1}{2}, \frac{1}{2}-u, \frac{1}{2}$ ;  $\frac{1}{2}, u+\frac{1}{2}, \frac{1}{2}$ .

Eight equivalent positions:

- (e)  $xyz$ ;  $x\bar{y}\bar{z}$ ;  $\bar{x}, y, \frac{1}{2}-z$ ;  $\bar{x}, \bar{y}, z+\frac{1}{2}$ ;  
 $\frac{1}{2}-x, \frac{1}{2}-y, \bar{z}$ ;  $\frac{1}{2}-x, y+\frac{1}{2}, z$ ;  $x+\frac{1}{2}, \frac{1}{2}-y, z+\frac{1}{2}$ ;  
 $x+\frac{1}{2}, y+\frac{1}{2}, \frac{1}{2}-z$ .

A slight simplification of the two *uniquely* defined positions [(a) and (b)] can be effected if the origin of coordinates is changed to the point  $\left(\frac{\tau_x}{2}, \frac{\tau_y}{2}\right)$  of this first set.

 SPACE-GROUP  $V_n^7$ .

Two equivalent positions:

- (a)  $\frac{1}{2}00$ ;  $\frac{1}{2}0\frac{1}{2}$ . (c)  $\frac{1}{2}\frac{1}{2}\frac{1}{2}$ ;  $\frac{1}{2}\frac{1}{2}0$ .  
 (b)  $\frac{1}{2}00$ ;  $\frac{1}{2}0\frac{1}{2}$ . (d)  $\frac{1}{2}\frac{1}{2}\frac{1}{2}$ ;  $\frac{1}{2}\frac{1}{2}0$ .

Four equivalent positions:

- (e)  $u00$ ;  $\bar{u}0\frac{1}{2}$ ;  $\frac{1}{2}-u, 0, 0$ ;  $u+\frac{1}{2}, 0, \frac{1}{2}$ .  
 (f)  $u\frac{1}{2}\frac{1}{2}$ ;  $\bar{u}\frac{1}{2}0$ ;  $\frac{1}{2}-u, \frac{1}{2}, \frac{1}{2}$ ;  $u+\frac{1}{2}, \frac{1}{2}, 0$ .  
 (g)  $0u\frac{1}{2}$ ;  $0\bar{u}\frac{1}{2}$ ;  $\frac{1}{2}\bar{u}\frac{1}{2}$ ;  $\frac{1}{2}u\frac{1}{2}$ .  
 (h)  $\frac{1}{2}uv$ ;  $\frac{1}{2}\bar{u}\bar{v}$ ;  $\frac{1}{2}, u, \frac{1}{2}-v$ ;  $\frac{1}{2}, \bar{u}, v+\frac{1}{2}$ .

Eight equivalent positions:

- (i)  $xyz$ ;  $x\bar{y}\bar{z}$ ;  $\bar{x}, y, \frac{1}{2}-z$ ;  $\bar{x}, \bar{y}, z+\frac{1}{2}$ ;  
 $\frac{1}{2}-x, \bar{y}, \bar{z}$ ;  $\frac{1}{2}-x, y, z$ ;  $x+\frac{1}{2}, \bar{y}, z+\frac{1}{2}$ ;  $x+\frac{1}{2}, y, \frac{1}{2}-z$ .

SPACE-GROUP  $V_2^7$  (continued).

By shifting the origin of coordinates to the point  $\left(\frac{\tau_x}{2}\right)$  of this first set, these positions become:

Two equivalent positions:

- (a)  $000$ ;  $\frac{1}{2}0\frac{1}{2}$ .      (c)  $0\frac{1}{2}\frac{1}{2}$ ;  $\frac{1}{2}\frac{1}{2}0$ .  
 (b)  $\frac{1}{2}00$ ;  $00\frac{1}{2}$ .      (d)  $\frac{1}{2}\frac{1}{2}\frac{1}{2}$ ;  $0\frac{1}{2}0$ .

Four equivalent positions:

- (e)  $u00$ ;  $\bar{u}00$ ;  $\frac{1}{2}-u, 0, \frac{1}{2}$ ;  $u+\frac{1}{2}, 0, \frac{1}{2}$ .  
 (f)  $u\frac{1}{2}\frac{1}{2}$ ;  $\bar{u}\frac{1}{2}\frac{1}{2}$ ;  $\frac{1}{2}-u, \frac{1}{2}, 0$ ;  $u+\frac{1}{2}, \frac{1}{2}, 0$ .  
 (g)  $\frac{1}{2}u\frac{1}{2}$ ;  $\frac{1}{2}\bar{u}\frac{1}{2}$ ;  $\frac{1}{2}u\frac{1}{2}$ ;  $\frac{1}{2}\bar{u}\frac{1}{2}$ .  
 (h)  $0uv$ ;  $0\bar{u}\bar{v}$ ;  $\frac{1}{2}, u, \frac{1}{2}-v$ ;  $\frac{1}{2}, \bar{u}, v+\frac{1}{2}$ .

Eight equivalent positions:

- (i)  $xyz$ ;  $x\bar{y}\bar{z}$ ;  $\frac{1}{2}-x, y, \frac{1}{2}-z$ ;  $\frac{1}{2}-x, \bar{y}, z+\frac{1}{2}$ ;  
 $\bar{x}\bar{y}\bar{z}$ ;  $\bar{x}yz$ ;  $x+\frac{1}{2}, \bar{y}, z+\frac{1}{2}$ ;  $x+\frac{1}{2}, y, \frac{1}{2}-z$ .

SPACE-GROUP  $V_2^8$ .

Four equivalent positions:

- (a)  $0\frac{1}{2}0$ ;  $0\frac{1}{2}0$ ;  $0\frac{1}{2}\frac{1}{2}$ ;  $0\frac{1}{2}\frac{1}{2}$ .  
 (b)  $\frac{1}{2}\frac{1}{2}\frac{1}{2}$ ;  $\frac{1}{2}\frac{1}{2}\frac{1}{2}$ ;  $\frac{1}{2}\frac{1}{2}0$ ;  $\frac{1}{2}\frac{1}{2}0$ .  
 (c)  $u00$ ;  $\bar{u}0\frac{1}{2}$ ;  $\bar{u}\frac{1}{2}0$ ;  $u\frac{1}{2}\frac{1}{2}$ .  
 (d)  $0u\frac{1}{2}$ ;  $0\bar{u}\frac{1}{2}$ ;  $0, \frac{1}{2}-u, \frac{1}{2}$ ;  $0, u+\frac{1}{2}, \frac{1}{2}$ .  
 (e)  $\frac{1}{2}u\frac{1}{2}$ ;  $\frac{1}{2}\bar{u}\frac{1}{2}$ ;  $\frac{1}{2}, \frac{1}{2}-u, \frac{1}{2}$ ;  $\frac{1}{2}, u+\frac{1}{2}, \frac{1}{2}$ .

Eight equivalent positions:

- (f)  $xyz$ ;  $x\bar{y}\bar{z}$ ;  $\bar{x}, y, \frac{1}{2}-z$ ;  $\bar{x}, \bar{y}, z+\frac{1}{2}$ ;  
 $\bar{x}, \frac{1}{2}-y, \bar{z}$ ;  $\bar{x}, y+\frac{1}{2}, z$ ;  $x, \frac{1}{2}-y, z+\frac{1}{2}$ ;  $x, y+\frac{1}{2}, \frac{1}{2}-z$ .

The *unique* cases can be simplified by transferring the origin to the point  $\left(\frac{\tau_y}{2}\right)$ .

SPACE-GROUP  $V_2^9$ .

Two equivalent positions:

- (a)  $000$ ;  $\frac{1}{2}\frac{1}{2}0$ .      (c)  $0\frac{1}{2}0$ ;  $\frac{1}{2}00$ .  
 (b)  $00\frac{1}{2}$ ;  $\frac{1}{2}\frac{1}{2}\frac{1}{2}$ .      (d)  $0\frac{1}{2}\frac{1}{2}$ ;  $\frac{1}{2}0\frac{1}{2}$ .

Four equivalent positions:

- (e)  $00u$ ;  $00\bar{u}$ ;  $\frac{1}{2}\frac{1}{2}\bar{u}$ ;  $\frac{1}{2}\frac{1}{2}u$ .  
 (f)  $0\frac{1}{2}u$ ;  $0\frac{1}{2}\bar{u}$ ;  $\frac{1}{2}0\bar{u}$ ;  $\frac{1}{2}0u$ .  
 (g)  $uv0$ ;  $\bar{u}\bar{v}0$ ;  $u+\frac{1}{2}, \frac{1}{2}-v, 0$ ;  $\frac{1}{2}-u, v+\frac{1}{2}, 0$ .  
 (h)  $uv\frac{1}{2}$ ;  $\bar{u}\bar{v}\frac{1}{2}$ ;  $u+\frac{1}{2}, \frac{1}{2}-v, \frac{1}{2}$ ;  $\frac{1}{2}-u, v+\frac{1}{2}, \frac{1}{2}$ .

Eight equivalent positions:

- (i)  $xyz$ ;  $x+\frac{1}{2}, \frac{1}{2}-y, \bar{z}$ ;  $\frac{1}{2}-x, y+\frac{1}{2}, \bar{z}$ ;  $\bar{x}\bar{y}\bar{z}$ ;  
 $\bar{x}\bar{y}\bar{z}$ ;  $\frac{1}{2}-x, y+\frac{1}{2}, z$ ;  $x+\frac{1}{2}, \frac{1}{2}-y, z$ ;  $xy\bar{z}$ .

SPACE-GROUP  $V_h^{10}$ .

Four equivalent positions:

- (a)  $\frac{1}{2} \frac{1}{2} \frac{1}{2}$ ;  $\frac{2}{2} \frac{1}{2} \frac{2}{2}$ ;  $\frac{1}{2} \frac{2}{2} \frac{2}{2}$ ;  $\frac{2}{2} \frac{2}{2} \frac{1}{2}$ .  
 (b)  $\frac{2}{2} \frac{2}{2} \frac{2}{2}$ ;  $\frac{1}{2} \frac{2}{2} \frac{1}{2}$ ;  $\frac{2}{2} \frac{1}{2} \frac{1}{2}$ ;  $\frac{1}{2} \frac{1}{2} \frac{2}{2}$ .  
 (c)  $00u$ ;  $\frac{1}{2} \frac{1}{2} \bar{u}$ ;  $\frac{1}{2}$ ,  $\frac{1}{2}$ ,  $\frac{1}{2}-u$ ;  $0, 0, u+\frac{1}{2}$ .  
 (d)  $0 \frac{1}{2} u$ ;  $\frac{1}{2} 0 \bar{u}$ ;  $\frac{1}{2}$ ,  $0$ ,  $\frac{1}{2}-u$ ;  $0, \frac{1}{2}, u+\frac{1}{2}$ .

Eight equivalent positions:

- (e)  $xyz$ ;  $x+\frac{1}{2}, \frac{1}{2}-y, \bar{z}$ ;  $\frac{1}{2}-x, y+\frac{1}{2}, \bar{z}$ ;  $\bar{x}\bar{y}z$ ;  
 $\frac{1}{2}-x, \frac{1}{2}-y, \frac{1}{2}-z$ ;  $\bar{x}, y, z+\frac{1}{2}$ ;  $x, \bar{y}, z+\frac{1}{2}$ ;  $\frac{1}{2}-x, \frac{1}{2}-y, z+\frac{1}{2}$ .

By shifting the origin to  $\left(\frac{\tau_x}{2}, \frac{\tau_y}{2}, \frac{\tau_z}{2}\right)$  the *uniquely* placed arrangements can be slightly simplified.

 SPACE-GROUP  $V_h^{11}$ .

Four equivalent positions:

- (a)  $0 \frac{1}{2} 0$ ;  $\frac{1}{2} \frac{1}{2} 0$ ;  $\frac{1}{2} \frac{2}{2} 0$ ;  $0 \frac{2}{2} 0$ .  
 (b)  $0 \frac{1}{2} \frac{1}{2}$ ;  $\frac{1}{2} \frac{1}{2} \frac{1}{2}$ ;  $\frac{1}{2} \frac{2}{2} \frac{1}{2}$ ;  $0 \frac{2}{2} \frac{1}{2}$ .  
 (c)  $00u$ ;  $\frac{1}{2} \frac{1}{2} \bar{u}$ ;  $0 \frac{1}{2} \bar{u}$ ;  $\frac{1}{2} 0 u$ .  
 (d)  $\frac{1}{2} u v$ ;  $\frac{2}{2} \bar{u} v$ ;  $\frac{2}{2}$ ,  $\frac{1}{2}-u$ ,  $\bar{v}$ ;  $\frac{1}{2}$ ,  $u+\frac{1}{2}$ ,  $\bar{v}$ .

Eight equivalent positions:

- (e)  $xyz$ ;  $x+\frac{1}{2}, \frac{1}{2}-y, \bar{z}$ ;  $\frac{1}{2}-x, y+\frac{1}{2}, \bar{z}$ ;  $\bar{x}\bar{y}z$ ;  
 $\bar{x}, \frac{1}{2}-y, \bar{z}$ ;  $\frac{1}{2}-x, y, z$ ;  $x+\frac{1}{2}, \bar{y}, z$ ;  $x, y+\frac{1}{2}, \bar{z}$ .

The *unique* cases can be simplified by placing the origin at the point  $\left(\frac{\tau_y}{2}\right)$ .

 SPACE-GROUP  $V_h^{12}$ .

Two equivalent positions:

- (a)  $00\frac{1}{2}$ ;  $\frac{1}{2}\frac{1}{2}\frac{2}{2}$ . (c)  $0\frac{1}{2}\frac{1}{2}$ ;  $\frac{1}{2}0\frac{2}{2}$ .  
 (b)  $00\frac{2}{2}$ ;  $\frac{1}{2}\frac{1}{2}\frac{1}{2}$ . (d)  $0\frac{1}{2}\frac{2}{2}$ ;  $\frac{1}{2}0\frac{1}{2}$ .

Four equivalent positions:

- (e)  $00u$ ;  $\frac{1}{2}\frac{1}{2}\bar{u}$ ;  $\frac{1}{2}$ ,  $\frac{1}{2}$ ,  $u+\frac{1}{2}$ ;  $0, 0, \frac{1}{2}-u$ .  
 (f)  $0\frac{1}{2}u$ ;  $\frac{1}{2}0\bar{u}$ ;  $\frac{1}{2}$ ,  $0$ ,  $u+\frac{1}{2}$ ;  $0, \frac{1}{2}, \frac{1}{2}-u$ .  
 (g)  $uv\frac{1}{2}$ ;  $\bar{u}\bar{v}\frac{1}{2}$ ;  $u+\frac{1}{2}, \frac{1}{2}-v, \frac{2}{2}$ ;  $\frac{1}{2}-u, v+\frac{1}{2}, \frac{2}{2}$ .

Eight equivalent positions:

- (h)  $xyz$ ;  $x+\frac{1}{2}, \frac{1}{2}-y, \bar{z}$ ;  $\frac{1}{2}-x, y+\frac{1}{2}, \bar{z}$ ;  $\bar{x}\bar{y}z$ ;  
 $\bar{x}, \bar{y}, \frac{1}{2}-z$ ;  $\frac{1}{2}-x, y+\frac{1}{2}, z+\frac{1}{2}$ ;  $x+\frac{1}{2}, \frac{1}{2}-y, z+\frac{1}{2}$ ;  $x, y, \frac{1}{2}-z$ .

The *unique* cases can be simplified by changing the origin to  $\left(\frac{\tau_x}{2}\right)$ .

 SPACE-GROUP  $V_h^{13}$ .

Two equivalent positions:

- (a)  $00u$ ;  $\frac{1}{2}\frac{1}{2}\bar{u}$ . (b)  $0\frac{1}{2}u$ ;  $\frac{1}{2}0\bar{u}$ .

SPACE-GROUP  $V_h^{13}$  (continued).

Four equivalent positions:

- (c)  $\frac{1}{2} \frac{1}{2} 0$ ;  $\frac{3}{2} \frac{1}{2} 0$ ;  $\frac{1}{2} \frac{3}{2} 0$ ;  $\frac{3}{2} \frac{3}{2} 0$ .  
 (d)  $\frac{1}{2} \frac{1}{2} \frac{1}{2}$ ;  $\frac{3}{2} \frac{1}{2} \frac{1}{2}$ ;  $\frac{1}{2} \frac{3}{2} \frac{1}{2}$ ;  $\frac{3}{2} \frac{3}{2} \frac{1}{2}$ .  
 (e)  $0 u v$ ;  $0 \bar{u} v$ ;  $\frac{1}{2}$ ,  $\frac{1}{2}-u$ ,  $\bar{v}$ ;  $\frac{1}{2}$ ,  $u+\frac{1}{2}$ ,  $\bar{v}$ .  
 (f)  $u 0 v$ ;  $\bar{u} 0 v$ ;  $\frac{1}{2}-u$ ,  $\frac{1}{2}$ ,  $\bar{v}$ ;  $u+\frac{1}{2}$ ,  $\frac{1}{2}$ ,  $\bar{v}$ .

Eight equivalent positions:

- (g)  $xyz$ ;  $x+\frac{1}{2}$ ,  $\frac{1}{2}-y$ ,  $\bar{z}$ ;  $\frac{1}{2}-x$ ,  $y+\frac{1}{2}$ ,  $\bar{z}$ ;  $\bar{x}\bar{y}z$ ;  
 $\frac{1}{2}-x$ ,  $\frac{1}{2}-y$ ,  $\bar{z}$ ;  $\bar{x}yz$ ;  $x\bar{y}z$ ;  $x+\frac{1}{2}$ ,  $y+\frac{1}{2}$ ,  $\bar{z}$ .

The *unique* cases can be simplified by changing the origin to  $\left(\frac{\tau_x}{2}, \frac{\tau_y}{2}\right)$ .

SPACE-GROUP  $V_h^{14}$ .

Four equivalent positions:

- (a)  $\frac{1}{2} 0 \frac{1}{2}$ ;  $\frac{3}{2} \frac{1}{2} \frac{1}{2}$ ;  $\frac{1}{2} \frac{3}{2} \frac{1}{2}$ ;  $\frac{3}{2} 0 \frac{1}{2}$ .  
 (b)  $\frac{3}{2} 0 \frac{1}{2}$ ;  $\frac{1}{2} \frac{3}{2} \frac{1}{2}$ ;  $\frac{3}{2} \frac{1}{2} \frac{1}{2}$ ;  $\frac{1}{2} 0 \frac{1}{2}$ .  
 (c)  $0 0 u$ ;  $\frac{1}{2} \frac{1}{2} \bar{u}$ ;  $\frac{1}{2}$ ,  $0$ ,  $\frac{1}{2}-u$ ;  $0$ ,  $\frac{1}{2}$ ,  $u+\frac{1}{2}$ .

Eight equivalent positions:

- (d)  $xyz$ ;  $x+\frac{1}{2}$ ,  $\frac{1}{2}-y$ ,  $\bar{z}$ ;  $\frac{1}{2}-x$ ,  $y+\frac{1}{2}$ ,  $\bar{z}$ ;  $\bar{x}\bar{y}z$ ;  
 $\frac{1}{2}-x$ ,  $\bar{y}$ ,  $\frac{1}{2}-z$ ;  $\bar{x}$ ,  $y+\frac{1}{2}$ ,  $z+\frac{1}{2}$ ;  $x$ ,  $\frac{1}{2}-y$ ,  $z+\frac{1}{2}$ ;  $x+\frac{1}{2}$ ,  $y$ ,  $\frac{1}{2}-z$ .

By changing the origin to the point  $\left(\frac{\tau_x}{2}, \frac{\tau_z}{2}\right)$  the *unique* cases are simplified.

SPACE-GROUP  $V_h^{15}$ .

Four equivalent positions:

- (a)  $0 0 0$ ;  $\frac{1}{2} \frac{1}{2} 0$ ;  $0 \frac{1}{2} \frac{1}{2}$ ;  $\frac{1}{2} 0 \frac{1}{2}$ .  
 (b)  $\frac{1}{2} \frac{1}{2} \frac{1}{2}$ ;  $0 0 \frac{1}{2}$ ;  $\frac{1}{2} 0 0$ ;  $0 \frac{1}{2} 0$ .

Eight equivalent positions:

- (c)  $xyz$ ;  $x+\frac{1}{2}$ ,  $\frac{1}{2}-y$ ,  $\bar{z}$ ;  $\bar{x}$ ,  $y+\frac{1}{2}$ ,  $\frac{1}{2}-z$ ;  $\frac{1}{2}-x$ ,  $\bar{y}$ ,  $z+\frac{1}{2}$ .  
 $\bar{x}\bar{y}\bar{z}$ ;  $\frac{1}{2}-x$ ,  $y+\frac{1}{2}$ ,  $z$ ;  $x$ ,  $\frac{1}{2}-y$ ,  $z+\frac{1}{2}$ ;  $x+\frac{1}{2}$ ,  $y$ ,  $\frac{1}{2}-z$ .

SPACE-GROUP  $V_h^{16}$ .

Four equivalent positions:

- (a)  $\frac{1}{2} \frac{1}{2} 0$ ;  $\frac{3}{2} \frac{1}{2} 0$ ;  $\frac{1}{2} \frac{3}{2} \frac{1}{2}$ ;  $\frac{3}{2} \frac{3}{2} \frac{1}{2}$ .  
 (b)  $\frac{1}{2} \frac{1}{2} \frac{1}{2}$ ;  $\frac{3}{2} \frac{1}{2} \frac{1}{2}$ ;  $\frac{1}{2} \frac{3}{2} 0$ ;  $\frac{3}{2} \frac{3}{2} 0$ .  
 (c)  $0 u v$ ;  $\frac{1}{2}$ ,  $\frac{1}{2}-u$ ,  $\bar{v}$ ;  $0$ ,  $u+\frac{1}{2}$ ,  $\frac{1}{2}-v$ ;  $\frac{1}{2}$ ,  $\bar{u}$ ,  $v+\frac{1}{2}$ .

Eight equivalent positions:

- (d)  $xyz$ ;  $x+\frac{1}{2}$ ,  $\frac{1}{2}-y$ ,  $\bar{z}$ ;  $\bar{x}$ ,  $y+\frac{1}{2}$ ,  $\frac{1}{2}-z$ ;  $\frac{1}{2}-x$ ,  $\bar{y}$ ,  $z+\frac{1}{2}$ ;  
 $\frac{1}{2}-x$ ,  $\frac{1}{2}-y$ ,  $\bar{z}$ ;  $\bar{x}yz$ ;  $x+\frac{1}{2}$ ,  $\bar{y}$ ,  $z+\frac{1}{2}$ ;  $x$ ,  $y+\frac{1}{2}$ ,  $\frac{1}{2}-z$ .

The *unique* cases are simplified when the origin is changed to  $\left(\frac{\tau_x}{2}, \frac{\tau_y}{2}\right)$ .

SPACE-GROUP  $V_h^{17}$ .

Four equivalent positions:

- (a)  $000$ ;  $00\frac{1}{2}$ ;  $\frac{1}{2}\frac{1}{2}0$ ;  $\frac{1}{2}\frac{1}{2}\frac{1}{2}$ .  
 (b)  $\frac{1}{2}00$ ;  $\frac{1}{2}0\frac{1}{2}$ ;  $0\frac{1}{2}0$ ;  $0\frac{1}{2}\frac{1}{2}$ .  
 (c)  $0u\frac{1}{2}$ ;  $0\bar{u}\frac{1}{2}$ ;  $\frac{1}{2}, u+\frac{1}{2}, \frac{1}{2}$ ;  $\frac{1}{2}, \frac{1}{2}-u, \frac{1}{2}$ .

Eight equivalent positions:

- (d)  $\frac{1}{2}\frac{1}{2}0$ ;  $\frac{1}{2}\frac{1}{2}0$ ;  $\frac{1}{2}\frac{1}{2}\frac{1}{2}$ ;  $\frac{1}{2}\frac{1}{2}\frac{1}{2}$ ;  
 $\frac{1}{2}\frac{1}{2}0$ ;  $\frac{1}{2}\frac{1}{2}0$ ;  $\frac{1}{2}\frac{1}{2}\frac{1}{2}$ ;  $\frac{1}{2}\frac{1}{2}\frac{1}{2}$ .  
 (e)  $u00$ ;  $\bar{u}00$ ;  $\frac{1}{2}-u, \frac{1}{2}, \frac{1}{2}$ ;  $u+\frac{1}{2}, \frac{1}{2}, \frac{1}{2}$ ;  
 $\bar{u}0\frac{1}{2}$ ;  $u0\frac{1}{2}$ ;  $u+\frac{1}{2}, \frac{1}{2}, 0$ ;  $\frac{1}{2}-u, \frac{1}{2}, 0$ .  
 (f)  $0uv$ ;  $0, u, \frac{1}{2}-v$ ;  $\frac{1}{2}, u+\frac{1}{2}, v$ ;  $\frac{1}{2}, u+\frac{1}{2}, \frac{1}{2}-v$ ;  
 $0\bar{u}\bar{v}$ ;  $0, \bar{u}, v+\frac{1}{2}$ ;  $\frac{1}{2}, \frac{1}{2}-u, \bar{v}$ ;  $\frac{1}{2}, \frac{1}{2}-u, v+\frac{1}{2}$ .  
 (g)  $uv\frac{1}{2}$ ;  $u\bar{v}\frac{1}{2}$ ;  $u+\frac{1}{2}, v+\frac{1}{2}, \frac{1}{2}$ ;  $u+\frac{1}{2}, \frac{1}{2}-v, \frac{1}{2}$ ;  
 $\bar{u}\bar{v}\frac{1}{2}$ ;  $\bar{u}v\frac{1}{2}$ ;  $\frac{1}{2}-u, \frac{1}{2}-v, \frac{1}{2}$ ;  $\frac{1}{2}-u, v+\frac{1}{2}, \frac{1}{2}$ .

Sixteen equivalent positions:

- (h)  $xyz$ ;  $x\bar{y}\bar{z}$ ;  $\bar{x}, y, \frac{1}{2}-z$ ;  $\bar{x}, \bar{y}, z+\frac{1}{2}$ ;  
 $\bar{x}\bar{y}z$ ;  $\bar{x}yz$ ;  $x, \bar{y}, z+\frac{1}{2}$ ;  $x, y, \frac{1}{2}-z$ ;  
 $x+\frac{1}{2}, y+\frac{1}{2}, z$ ;  $x+\frac{1}{2}, \frac{1}{2}-y, \bar{z}$ ;  $\frac{1}{2}-x, y+\frac{1}{2}, \frac{1}{2}-z$ ;  
 $\frac{1}{2}-x, \frac{1}{2}-y, z+\frac{1}{2}$ ;  
 $\frac{1}{2}-x, \frac{1}{2}-y, \bar{z}$ ;  $\frac{1}{2}-x, y+\frac{1}{2}, z$ ;  $x+\frac{1}{2}, \frac{1}{2}-y, z+\frac{1}{2}$ ;  
 $x+\frac{1}{2}, y+\frac{1}{2}, \frac{1}{2}-z$ .

SPACE-GROUP  $V_h^{18}$ .

Four equivalent positions:

- (a)  $\frac{1}{2}00$ ;  $\frac{1}{2}0\frac{1}{2}$ ;  $\frac{1}{2}\frac{1}{2}0$ ;  $\frac{1}{2}\frac{1}{2}\frac{1}{2}$ .  
 (b)  $\frac{1}{2}00$ ;  $\frac{1}{2}0\frac{1}{2}$ ;  $\frac{1}{2}\frac{1}{2}0$ ;  $\frac{1}{2}\frac{1}{2}\frac{1}{2}$ .

Eight equivalent positions:

- (c)  $0\frac{1}{2}0$ ;  $0\frac{1}{2}0$ ;  $0\frac{1}{2}\frac{1}{2}$ ;  $0\frac{1}{2}\frac{1}{2}$ ;  
 $\frac{1}{2}\frac{1}{2}0$ ;  $\frac{1}{2}\frac{1}{2}0$ ;  $\frac{1}{2}\frac{1}{2}\frac{1}{2}$ ;  $\frac{1}{2}\frac{1}{2}\frac{1}{2}$ .  
 (d)  $u00$ ;  $\bar{u}0\frac{1}{2}$ ;  $\frac{1}{2}-u, 0, 0$ ;  $u+\frac{1}{2}, 0, \frac{1}{2}$ ;  
 $u\frac{1}{2}\frac{1}{2}$ ;  $\bar{u}\frac{1}{2}0$ ;  $\frac{1}{2}-u, \frac{1}{2}, \frac{1}{2}$ ;  $u+\frac{1}{2}, \frac{1}{2}, 0$ .  
 (e)  $0u\frac{1}{2}$ ;  $\frac{1}{2}\bar{u}\frac{1}{2}$ ;  $\frac{1}{2}, \frac{1}{2}-u, \frac{1}{2}$ ;  $0, u+\frac{1}{2}, \frac{1}{2}$ ;  
 $0\bar{u}\frac{1}{2}$ ;  $\frac{1}{2}u\frac{1}{2}$ ;  $\frac{1}{2}, u+\frac{1}{2}, \frac{1}{2}$ ;  $0, \frac{1}{2}-u, \frac{1}{2}$ .  
 (f)  $\frac{1}{2}uv$ ;  $\frac{1}{2}, u, \frac{1}{2}-v$ ;  $\frac{1}{2}, u+\frac{1}{2}, v$ ;  $\frac{1}{2}, u+\frac{1}{2}, \frac{1}{2}-v$ ;  
 $\frac{1}{2}\bar{u}\bar{v}$ ;  $\frac{1}{2}, \bar{u}, v+\frac{1}{2}$ ;  $\frac{1}{2}, \frac{1}{2}-u, \bar{v}$ ;  $\frac{1}{2}, \frac{1}{2}-u, v+\frac{1}{2}$ .

Sixteen equivalent positions:

- (g)  $xyz$ ;  $x\bar{y}\bar{z}$ ;  $\bar{x}, y, \frac{1}{2}-z$ ;  $\bar{x}, \bar{y}, z+\frac{1}{2}$ ;  
 $\frac{1}{2}-x, \bar{y}, \bar{z}$ ;  $\frac{1}{2}-x, y, z$ ;  $x+\frac{1}{2}, \bar{y}, z+\frac{1}{2}$ ;  $x+\frac{1}{2}, y, \frac{1}{2}-z$ ;  
 $x+\frac{1}{2}, y+\frac{1}{2}, z$ ;  $x+\frac{1}{2}, \frac{1}{2}-y, \bar{z}$ ;  $\frac{1}{2}-x, y+\frac{1}{2}, \frac{1}{2}-z$ ;  
 $\frac{1}{2}-x, \frac{1}{2}-y, z+\frac{1}{2}$ ;  
 $\bar{x}, \frac{1}{2}-y, \bar{z}$ ;  $\bar{x}, y+\frac{1}{2}, z$ ;  $x, \frac{1}{2}-y, z+\frac{1}{2}$ ;  $x, y+\frac{1}{2}, \frac{1}{2}-z$ .

SPACE-GROUP  $V_n^{13}$  (continued).

Four equivalent positions:

- (a)  $\frac{1}{2} \frac{1}{2} 0$ ;  $\frac{3}{2} \frac{1}{2} 0$ ;  $\frac{1}{2} \frac{3}{2} 0$ ;  $\frac{3}{2} \frac{3}{2} 0$ .  
 (d)  $\frac{1}{2} \frac{1}{2} \frac{1}{2}$ ;  $\frac{3}{2} \frac{1}{2} \frac{1}{2}$ ;  $\frac{1}{2} \frac{3}{2} \frac{1}{2}$ ;  $\frac{3}{2} \frac{3}{2} \frac{1}{2}$ .  
 (e)  $0 u v$ ;  $0 \bar{u} v$ ;  $\frac{1}{2}$ ,  $\frac{1}{2}-u$ ,  $\bar{v}$ ;  $\frac{1}{2}$ ,  $u+\frac{1}{2}$ ,  $\bar{v}$ .  
 (f)  $u 0 v$ ;  $\bar{u} 0 v$ ;  $\frac{1}{2}-u$ ,  $\frac{1}{2}$ ,  $\bar{v}$ ;  $u+\frac{1}{2}$ ,  $\frac{1}{2}$ ,  $\bar{v}$ .

Eight equivalent positions:

- (g)  $xyz$ ;  $x+\frac{1}{2}$ ,  $\frac{1}{2}-y$ ,  $\bar{z}$ ;  $\frac{1}{2}-x$ ,  $y+\frac{1}{2}$ ,  $\bar{z}$ ;  $\bar{x}\bar{y}z$ ;  
 $\frac{1}{2}-x$ ,  $\frac{1}{2}-y$ ,  $\bar{z}$ ;  $\bar{x}yz$ ;  $x\bar{y}z$ ;  $x+\frac{1}{2}$ ,  $y+\frac{1}{2}$ ,  $\bar{z}$ .

The *unique* cases can be simplified by changing the origin to  $\left(\frac{\tau_x}{2}, \frac{\tau_y}{2}\right)$ .

SPACE-GROUP  $V_n^{14}$ .

Four equivalent positions:

- (a)  $\frac{1}{2} 0 \frac{1}{2}$ ;  $\frac{3}{2} \frac{1}{2} \frac{1}{2}$ ;  $\frac{1}{2} \frac{3}{2} \frac{1}{2}$ ;  $\frac{3}{2} 0 \frac{1}{2}$ .  
 (b)  $\frac{1}{2} 0 \frac{3}{2}$ ;  $\frac{1}{2} \frac{1}{2} \frac{1}{2}$ ;  $\frac{3}{2} \frac{1}{2} \frac{1}{2}$ ;  $\frac{1}{2} 0 \frac{3}{2}$ .  
 (c)  $0 0 u$ ;  $\frac{1}{2} \frac{1}{2} \bar{u}$ ;  $\frac{1}{2}$ ,  $0$ ,  $\frac{1}{2}-u$ ;  $0$ ,  $\frac{1}{2}$ ,  $u+\frac{1}{2}$ .

Eight equivalent positions:

- (d)  $xyz$ ;  $x+\frac{1}{2}$ ,  $\frac{1}{2}-y$ ,  $\bar{z}$ ;  $\frac{1}{2}-x$ ,  $y+\frac{1}{2}$ ,  $\bar{z}$ ;  $\bar{x}\bar{y}z$ ;  
 $\frac{1}{2}-x$ ,  $\bar{y}$ ,  $\frac{1}{2}-z$ ;  $\bar{x}$ ,  $y+\frac{1}{2}$ ,  $z+\frac{1}{2}$ ;  $x$ ,  $\frac{1}{2}-y$ ,  $z+\frac{1}{2}$ ;  $x+\frac{1}{2}$ ,  $y$ ,  $\frac{1}{2}-z$ .

By changing the origin to the point  $\left(\frac{\tau_x}{2}, \frac{\tau_y}{2}\right)$  the *unique* cases are simplified.

SPACE-GROUP  $V_n^{15}$ .

Four equivalent positions:

- (a)  $0 0 0$ ;  $\frac{1}{2} \frac{1}{2} 0$ ;  $0 \frac{1}{2} \frac{1}{2}$ ;  $\frac{1}{2} 0 \frac{1}{2}$ .  
 (b)  $\frac{1}{2} \frac{1}{2} \frac{1}{2}$ ;  $0 0 \frac{1}{2}$ ;  $\frac{1}{2} 0 0$ ;  $0 \frac{1}{2} 0$ .

Eight equivalent positions:

- (c)  $xyz$ ;  $x+\frac{1}{2}$ ,  $\frac{1}{2}-y$ ,  $\bar{z}$ ;  $\bar{x}$ ,  $y+\frac{1}{2}$ ,  $\frac{1}{2}-z$ ;  $\frac{1}{2}-x$ ,  $\bar{y}$ ,  $z+\frac{1}{2}$ .  
 $\bar{x}\bar{y}z$ ;  $\frac{1}{2}-x$ ,  $y+\frac{1}{2}$ ,  $z$ ;  $x$ ,  $\frac{1}{2}-y$ ,  $z+\frac{1}{2}$ ;  $x+\frac{1}{2}$ ,  $y$ ,  $\frac{1}{2}-z$ .

SPACE-GROUP  $V_n^{16}$ .

Four equivalent positions:

- (a)  $\frac{1}{2} \frac{1}{2} 0$ ;  $\frac{3}{2} \frac{1}{2} 0$ ;  $\frac{1}{2} \frac{3}{2} \frac{1}{2}$ ;  $\frac{3}{2} \frac{3}{2} \frac{1}{2}$ .  
 (b)  $\frac{1}{2} \frac{1}{2} \frac{1}{2}$ ;  $\frac{3}{2} \frac{1}{2} \frac{1}{2}$ ;  $\frac{1}{2} \frac{3}{2} 0$ ;  $\frac{3}{2} \frac{3}{2} 0$ .  
 (c)  $0 u v$ ;  $\frac{1}{2}$ ,  $\frac{1}{2}-u$ ,  $\bar{v}$ ;  $0$ ,  $u+\frac{1}{2}$ ,  $\frac{1}{2}-v$ ;  $\frac{1}{2}$ ,  $\bar{u}$ ,  $v+\frac{1}{2}$ .

Eight equivalent positions:

- (d)  $xyz$ ;  $x+\frac{1}{2}$ ,  $\frac{1}{2}-y$ ,  $\bar{z}$ ;  $\bar{x}$ ,  $y+\frac{1}{2}$ ,  $\frac{1}{2}-z$ ;  $\frac{1}{2}-x$ ,  $\bar{y}$ ,  $z+\frac{1}{2}$ ;  
 $\frac{1}{2}-x$ ,  $\frac{1}{2}-y$ ,  $\bar{z}$ ;  $\bar{x}yz$ ;  $x+\frac{1}{2}$ ,  $\bar{y}$ ,  $z+\frac{1}{2}$ ;  $x$ ,  $y+\frac{1}{2}$ ,  $\frac{1}{2}-z$ .

The *unique* cases are simplified when the origin is changed

SPACE-GROUP  $V_h^{17}$ .

Four equivalent positions:

- (a)  $000$ ;  $00\frac{1}{2}$ ;  $\frac{1}{2}\frac{1}{2}0$ ;  $\frac{1}{2}\frac{1}{2}\frac{1}{2}$ .
- (b)  $\frac{1}{2}00$ ;  $\frac{1}{2}0\frac{1}{2}$ ;  $0\frac{1}{2}0$ ;  $0\frac{1}{2}\frac{1}{2}$ .
- (c)  $0u\frac{1}{2}$ ;  $0\bar{u}\frac{1}{2}$ ;  $\frac{1}{2}, u+\frac{1}{2}, \frac{1}{2}$ ;  $\frac{1}{2}, \frac{1}{2}-u, \frac{1}{2}$ .

Eight equivalent positions:

- (d)  $\frac{1}{2}\frac{1}{2}0$ ;  $\frac{1}{2}\frac{1}{2}0$ ;  $\frac{1}{2}\frac{1}{2}\frac{1}{2}$ ;  $\frac{1}{2}\frac{1}{2}\frac{1}{2}$ ;  
 $\frac{1}{2}\frac{1}{2}0$ ;  $\frac{1}{2}\frac{1}{2}0$ ;  $\frac{1}{2}\frac{1}{2}\frac{1}{2}$ ;  $\frac{1}{2}\frac{1}{2}\frac{1}{2}$ .
- (e)  $u00$ ;  $\bar{u}00$ ;  $\frac{1}{2}-u, \frac{1}{2}, \frac{1}{2}$ ;  $u+\frac{1}{2}, \frac{1}{2}, \frac{1}{2}$ ;  
 $\bar{u}0\frac{1}{2}$ ;  $u0\frac{1}{2}$ ;  $u+\frac{1}{2}, \frac{1}{2}, 0$ ;  $\frac{1}{2}-u, \frac{1}{2}, 0$ .
- (f)  $0uv$ ;  $0, u, \frac{1}{2}-v$ ;  $\frac{1}{2}, u+\frac{1}{2}, v$ ;  $\frac{1}{2}, u+\frac{1}{2}, \frac{1}{2}-v$ ;  
 $0\bar{u}\bar{v}$ ;  $0, \bar{u}, v+\frac{1}{2}$ ;  $\frac{1}{2}, \frac{1}{2}-u, \bar{v}$ ;  $\frac{1}{2}, \frac{1}{2}-u, v+\frac{1}{2}$ .
- (g)  $uv\frac{1}{2}$ ;  $u\bar{v}\frac{1}{2}$ ;  $u+\frac{1}{2}, v+\frac{1}{2}, \frac{1}{2}$ ;  $u+\frac{1}{2}, \frac{1}{2}-v, \frac{1}{2}$ ;  
 $\bar{u}\bar{v}\frac{1}{2}$ ;  $\bar{u}v\frac{1}{2}$ ;  $\frac{1}{2}-u, \frac{1}{2}-v, \frac{1}{2}$ ;  $\frac{1}{2}-u, v+\frac{1}{2}, \frac{1}{2}$ .

Sixteen equivalent positions:

- (h)  $xyz$ ;  $x\bar{y}\bar{z}$ ;  $\bar{x}, y, \frac{1}{2}-z$ ;  $\bar{x}, \bar{y}, z+\frac{1}{2}$ ;  
 $\bar{x}\bar{y}\bar{z}$ ;  $\bar{x}yz$ ;  $x, \bar{y}, z+\frac{1}{2}$ ;  $x, y, \frac{1}{2}-z$ ;  
 $x+\frac{1}{2}, y+\frac{1}{2}, z$ ;  $x+\frac{1}{2}, \frac{1}{2}-y, \bar{z}$ ;  $\frac{1}{2}-x, y+\frac{1}{2}, \frac{1}{2}-z$ ;  
 $\frac{1}{2}-x, \frac{1}{2}-y, z+\frac{1}{2}$ ;  
 $\frac{1}{2}-x, \frac{1}{2}-y, \bar{z}$ ;  $\frac{1}{2}-x, y+\frac{1}{2}, z$ ;  $x+\frac{1}{2}, \frac{1}{2}-y, z+\frac{1}{2}$ ;  
 $x+\frac{1}{2}, y+\frac{1}{2}, \frac{1}{2}-z$ .

SPACE-GROUP  $V_h^{18}$ .

Four equivalent positions:

- (a)  $\frac{1}{2}00$ ;  $\frac{1}{2}0\frac{1}{2}$ ;  $\frac{1}{2}\frac{1}{2}0$ ;  $\frac{1}{2}\frac{1}{2}\frac{1}{2}$ .
- (b)  $\frac{1}{2}00$ ;  $\frac{1}{2}0\frac{1}{2}$ ;  $\frac{1}{2}\frac{1}{2}0$ ;  $\frac{1}{2}\frac{1}{2}\frac{1}{2}$ .

Eight equivalent positions:

- (c)  $0\frac{1}{2}0$ ;  $0\frac{1}{2}0$ ;  $0\frac{1}{2}\frac{1}{2}$ ;  $0\frac{1}{2}\frac{1}{2}$ ;  
 $\frac{1}{2}\frac{1}{2}0$ ;  $\frac{1}{2}\frac{1}{2}0$ ;  $\frac{1}{2}\frac{1}{2}\frac{1}{2}$ ;  $\frac{1}{2}\frac{1}{2}\frac{1}{2}$ .
- (d)  $u00$ ;  $\bar{u}0\frac{1}{2}$ ;  $\frac{1}{2}-u, \frac{1}{2}, \frac{1}{2}$ ;  $u+\frac{1}{2}, 0, \frac{1}{2}$ ;  
 $u\frac{1}{2}\frac{1}{2}$ ;  $\bar{u}\frac{1}{2}0$ ;  $\frac{1}{2}-u, \frac{1}{2}, 0$ ;  $u+\frac{1}{2}, \frac{1}{2}, 0$ .
- (e)  $0u\frac{1}{2}$ ;  $0\bar{u}\frac{1}{2}$ ;  $\frac{1}{2}, u+\frac{1}{2}, \frac{1}{2}$ ;  $0, u+\frac{1}{2}, \frac{1}{2}$ ;  
 $0\bar{u}\frac{1}{2}$ ;  $0u\frac{1}{2}$ ;  $\frac{1}{2}, \frac{1}{2}-u, \frac{1}{2}$ ;  $0, \frac{1}{2}-u, \frac{1}{2}$ .

- $\bar{x}, y, \frac{1}{2}-z$ ;  $\bar{x}, \bar{y}, z+\frac{1}{2}$ ;  
 $x+\frac{1}{2}, \bar{y}, z+\frac{1}{2}$ ;  $x+\frac{1}{2}, y, \frac{1}{2}-z$ ;  
 $\frac{1}{2}-x, y, \bar{z}$ ;  $\frac{1}{2}-x, y+\frac{1}{2}, \frac{1}{2}-z$ ;  
 $\frac{1}{2}-x, \frac{1}{2}-y, z+\frac{1}{2}$ ;  
 $x, \frac{1}{2}-y, z+\frac{1}{2}$ ;  $x, y+\frac{1}{2}, \frac{1}{2}-z$ .



SPACE-GROUP  $V_h^{19}$ .

Two equivalent positions:

- (a)  $000$ ;  $\frac{1}{2}\frac{1}{2}0$ .      (c)  $0\frac{1}{2}\frac{1}{2}$ ;  $\frac{1}{2}0\frac{1}{2}$ .  
 (b)  $\frac{1}{2}00$ ;  $0\frac{1}{2}0$ .      (d)  $\frac{1}{2}\frac{1}{2}\frac{1}{2}$ ;  $00\frac{1}{2}$ .

Four equivalent positions:

- (e)  $\frac{1}{2}\frac{1}{2}0$ ;  $\frac{1}{2}\frac{1}{2}0$ ;  $\frac{1}{2}\frac{1}{2}0$ ;  $\frac{1}{2}\frac{1}{2}0$ .  
 (f)  $\frac{1}{2}\frac{1}{2}\frac{1}{2}$ ;  $\frac{1}{2}\frac{1}{2}\frac{1}{2}$ ;  $\frac{1}{2}\frac{1}{2}\frac{1}{2}$ ;  $\frac{1}{2}\frac{1}{2}\frac{1}{2}$ .  
 (g)  $u00$ ;  $\bar{u}00$ ;  $u+\frac{1}{2}, \frac{1}{2}, 0$ ;  $\frac{1}{2}-u, \frac{1}{2}, 0$ .  
 (h)  $u\frac{1}{2}\frac{1}{2}$ ;  $\bar{u}\frac{1}{2}\frac{1}{2}$ ;  $u+\frac{1}{2}, 0, \frac{1}{2}$ ;  $\frac{1}{2}-u, 0, \frac{1}{2}$ .  
 (i)  $0u0$ ;  $0\bar{u}0$ ;  $\frac{1}{2}, u+\frac{1}{2}, 0$ ;  $\frac{1}{2}, \frac{1}{2}-u, 0$ .  
 (j)  $\frac{1}{2}u\frac{1}{2}$ ;  $\frac{1}{2}\bar{u}\frac{1}{2}$ ;  $0, u+\frac{1}{2}, \frac{1}{2}$ ;  $0, \frac{1}{2}-u, \frac{1}{2}$ .  
 (k)  $00u$ ;  $00\bar{u}$ ;  $\frac{1}{2}\frac{1}{2}u$ ;  $\frac{1}{2}\frac{1}{2}\bar{u}$ .  
 (l)  $0\frac{1}{2}u$ ;  $0\frac{1}{2}\bar{u}$ ;  $\frac{1}{2}0u$ ;  $\frac{1}{2}0\bar{u}$ .

Eight equivalent positions:

- (m)  $\frac{1}{2}\frac{1}{2}u$ ;  $\frac{1}{2}\frac{1}{2}\bar{u}$ ;  $\frac{1}{2}\frac{1}{2}\bar{u}$ ;  $\frac{1}{2}\frac{1}{2}u$ ;  
 $\frac{1}{2}\frac{1}{2}\bar{u}$ ;  $\frac{1}{2}\frac{1}{2}u$ ;  $\frac{1}{2}\frac{1}{2}\bar{u}$ ;  $\frac{1}{2}\frac{1}{2}\bar{u}$ .  
 (n)  $0uv$ ;  $0u\bar{v}$ ;  $\frac{1}{2}, u+\frac{1}{2}, v$ ;  $\frac{1}{2}, u+\frac{1}{2}, \bar{v}$ ;  
 $0\bar{u}v$ ;  $0\bar{u}\bar{v}$ ;  $\frac{1}{2}, \frac{1}{2}-u, v$ ;  $\frac{1}{2}, \frac{1}{2}-u, \bar{v}$ .  
 (o)  $u0v$ ;  $\bar{u}0\bar{v}$ ;  $u+\frac{1}{2}, \frac{1}{2}, v$ ;  $\frac{1}{2}-u, \frac{1}{2}, \bar{v}$ ;  
 $u0\bar{v}$ ;  $\bar{u}0v$ ;  $u+\frac{1}{2}, \frac{1}{2}, \bar{v}$ ;  $\frac{1}{2}-u, \frac{1}{2}, v$ .  
 (p)  $uv0$ ;  $\bar{u}\bar{v}0$ ;  $u+\frac{1}{2}, v+\frac{1}{2}, 0$ ;  $\frac{1}{2}-u, \frac{1}{2}-v, 0$ ;  
 $u\bar{v}0$ ;  $\bar{u}v0$ ;  $u+\frac{1}{2}, \frac{1}{2}-v, 0$ ;  $\frac{1}{2}-u, v+\frac{1}{2}, 0$ .  
 (q)  $uv\frac{1}{2}$ ;  $\bar{u}\bar{v}\frac{1}{2}$ ;  $u+\frac{1}{2}, v+\frac{1}{2}, \frac{1}{2}$ ;  $\frac{1}{2}-u, \frac{1}{2}-v, \frac{1}{2}$ ;  
 $u\bar{v}\frac{1}{2}$ ;  $\bar{u}v\frac{1}{2}$ ;  $u+\frac{1}{2}, \frac{1}{2}-v, \frac{1}{2}$ ;  $\frac{1}{2}-u, v+\frac{1}{2}, \frac{1}{2}$ .

Sixteen equivalent positions

- (r)  $xyz$ ;  $x\bar{y}\bar{z}$ ;  $\bar{x}y\bar{z}$ ;  $\bar{x}\bar{y}z$ ;  
 $\bar{x}\bar{y}\bar{z}$ ;  $\bar{x}yz$ ;  $x\bar{y}z$ ;  $xy\bar{z}$ ;  
 $x+\frac{1}{2}, y+\frac{1}{2}, z$ ;  $x+\frac{1}{2}, \frac{1}{2}-y, \bar{z}$ ;  $\frac{1}{2}-x, y+\frac{1}{2}, \bar{z}$ ;  $\frac{1}{2}-x, \frac{1}{2}-y, z$ ;  
 $\frac{1}{2}-x, \frac{1}{2}-y, \bar{z}$ ;  $\frac{1}{2}-x, y+\frac{1}{2}, z$ ;  $x+\frac{1}{2}, \frac{1}{2}-y, z$ ;  $x+\frac{1}{2}, y+\frac{1}{2}, \bar{z}$ .

SPACE-GROUP  $V_h^{20}$ .

Four equivalent positions:

- (a)  $000$ ;  $00\frac{1}{2}$ ;  $\frac{1}{2}\frac{1}{2}0$ ;  $\frac{1}{2}\frac{1}{2}\frac{1}{2}$ .  
 (b)  $\frac{1}{2}00$ ;  $\frac{1}{2}0\frac{1}{2}$ ;  $0\frac{1}{2}0$ ;  $0\frac{1}{2}\frac{1}{2}$ .  
 (c)  $00\frac{1}{2}$ ;  $00\frac{1}{2}$ ;  $\frac{1}{2}\frac{1}{2}\frac{1}{2}$ ;  $\frac{1}{2}\frac{1}{2}\frac{1}{2}$ .  
 (d)  $0\frac{1}{2}\frac{1}{2}$ ;  $0\frac{1}{2}\frac{1}{2}$ ;  $\frac{1}{2}0\frac{1}{2}$ ;  $\frac{1}{2}0\frac{1}{2}$ .  
 (e)  $\frac{1}{2}\frac{1}{2}\frac{1}{2}$ ;  $\frac{1}{2}\frac{1}{2}\frac{1}{2}$ ;  $\frac{1}{2}\frac{1}{2}\frac{1}{2}$ ;  $\frac{1}{2}\frac{1}{2}\frac{1}{2}$ .  
 (f)  $\frac{1}{2}\frac{1}{2}\frac{1}{2}$ ;  $\frac{1}{2}\frac{1}{2}\frac{1}{2}$ ;  $\frac{1}{2}\frac{1}{2}\frac{1}{2}$ ;  $\frac{1}{2}\frac{1}{2}\frac{1}{2}$ .

Eight equivalent positions:

- (g)  $u00$ ;  $u0\frac{1}{2}$ ;  $u+\frac{1}{2}, \frac{1}{2}, 0$ ;  $u+\frac{1}{2}, \frac{1}{2}, \frac{1}{2}$ ;  
 $\bar{u}00$ ;  $\bar{u}0\frac{1}{2}$ ;  $\frac{1}{2}-u, \frac{1}{2}, 0$ ;  $\frac{1}{2}-u, \frac{1}{2}, \frac{1}{2}$ .  
 (h)  $0u0$ ;  $0u\frac{1}{2}$ ;  $\frac{1}{2}, u+\frac{1}{2}, 0$ ;  $\frac{1}{2}, u+\frac{1}{2}, \frac{1}{2}$ ;  
 $0\bar{u}0$ ;  $0\bar{u}\frac{1}{2}$ ;  $\frac{1}{2}, \frac{1}{2}-u, 0$ ;  $\frac{1}{2}, \frac{1}{2}-u, \frac{1}{2}$ .

SPACE-GROUP  $V_h^{20}$  (continued).

- (i)  $00u$ ;  $\frac{1}{2}\frac{1}{2}u$ ;  $0, 0, u+\frac{1}{2}$ ;  $\frac{1}{2}, \frac{1}{2}, u+\frac{1}{2}$ ;  
 $00\bar{u}$ ;  $\frac{1}{2}\frac{1}{2}\bar{u}$ ;  $0, 0, \frac{1}{2}-u$ ;  $\frac{1}{2}, \frac{1}{2}, \frac{1}{2}-u$ .  
(j)  $0\frac{1}{2}u$ ;  $\frac{1}{2}0u$ ;  $0, \frac{1}{2}, u+\frac{1}{2}$ ;  $\frac{1}{2}, 0, u+\frac{1}{2}$ ;  
 $0\frac{1}{2}\bar{u}$ ;  $\frac{1}{2}0\bar{u}$ ;  $0, \frac{1}{2}, \frac{1}{2}-u$ ;  $\frac{1}{2}, 0, \frac{1}{2}-u$ .  
(k)  $\frac{1}{2}\frac{1}{2}u$ ;  $\frac{1}{2}\frac{1}{2}\bar{u}$ ;  $\frac{1}{2}, \frac{1}{2}, \frac{1}{2}-u$ ;  $\frac{1}{2}, \frac{1}{2}, u+\frac{1}{2}$ ;  
 $\frac{1}{2}\frac{1}{2}u$ ;  $\frac{1}{2}\frac{1}{2}\bar{u}$ ;  $\frac{1}{2}, \frac{1}{2}, \frac{1}{2}-u$ ;  $\frac{1}{2}, \frac{1}{2}, u+\frac{1}{2}$ .  
(l)  $uv\frac{1}{2}$ ;  $u\bar{v}\frac{1}{2}$ ;  $u+\frac{1}{2}, v+\frac{1}{2}, \frac{1}{2}$ ;  $u+\frac{1}{2}, \frac{1}{2}-v, \frac{1}{2}$ ;  
 $\bar{u}v\frac{1}{2}$ ;  $\bar{u}\bar{v}\frac{1}{2}$ ;  $\frac{1}{2}-u, \frac{1}{2}-v, \frac{1}{2}$ ;  $\frac{1}{2}-u, v+\frac{1}{2}, \frac{1}{2}$ .

Sixteen equivalent positions:

- (m)  $xyz$ ;  $x\bar{y}\bar{z}$ ;  $\bar{x}y\bar{z}$ ;  $\bar{x}\bar{y}z$ ;  
 $\bar{x}, \bar{y}, \frac{1}{2}-z$ ;  $\bar{x}, y, z+\frac{1}{2}$ ;  $x, \bar{y}, z+\frac{1}{2}$ ;  $x, y, \frac{1}{2}-z$ ;  
 $x+\frac{1}{2}, y+\frac{1}{2}, z$ ;  $x+\frac{1}{2}, \frac{1}{2}-y, \bar{z}$ ;  $\frac{1}{2}-x, y+\frac{1}{2}, \bar{z}$ ;  
 $\frac{1}{2}-x, \frac{1}{2}-y, z$ ;  $\frac{1}{2}-x, y+\frac{1}{2}, z+\frac{1}{2}$ ;  $x+\frac{1}{2}, \frac{1}{2}-y, z+\frac{1}{2}$ ;  
 $x+\frac{1}{2}, y+\frac{1}{2}, \frac{1}{2}-z$ .

SPACE-GROUP  $V_h^{21}$ .

Four equivalent positions:

- (a)  $000$ ;  $\frac{1}{2}00$ ;  $\frac{1}{2}\frac{1}{2}0$ ;  $0\frac{1}{2}0$ .  
(b)  $00\frac{1}{2}$ ;  $\frac{1}{2}0\frac{1}{2}$ ;  $\frac{1}{2}\frac{1}{2}\frac{1}{2}$ ;  $0\frac{1}{2}\frac{1}{2}$ .  
(c)  $\frac{1}{2}00$ ;  $\frac{1}{2}00$ ;  $\frac{1}{2}\frac{1}{2}0$ ;  $\frac{1}{2}\frac{1}{2}0$ .  
(d)  $\frac{1}{2}\frac{1}{2}\frac{1}{2}$ ;  $\frac{1}{2}\frac{1}{2}\frac{1}{2}$ ;  $\frac{1}{2}0\frac{1}{2}$ ;  $\frac{1}{2}0\frac{1}{2}$ .  
(e)  $0\frac{1}{2}0$ ;  $0\frac{1}{2}0$ ;  $\frac{1}{2}\frac{1}{2}0$ ;  $\frac{1}{2}\frac{1}{2}0$ .  
(f)  $\frac{1}{2}\frac{1}{2}\frac{1}{2}$ ;  $\frac{1}{2}\frac{1}{2}\frac{1}{2}$ ;  $0\frac{1}{2}\frac{1}{2}$ ;  $0\frac{1}{2}\frac{1}{2}$ .  
(g)  $\frac{1}{2}\frac{1}{2}u$ ;  $\frac{1}{2}\frac{1}{2}\bar{u}$ ;  $\frac{1}{2}\frac{1}{2}\bar{u}$ ;  $\frac{1}{2}\frac{1}{2}u$ .

Eight equivalent positions:

- (h)  $u00$ ;  $\bar{u}\frac{1}{2}0$ ;  $\frac{1}{2}-u, \frac{1}{2}, 0$ ;  $u+\frac{1}{2}, 0, 0$ ;  
 $\bar{u}00$ ;  $u\frac{1}{2}0$ ;  $u+\frac{1}{2}, \frac{1}{2}, 0$ ;  $\frac{1}{2}-u, 0, 0$ .  
(i)  $u\frac{1}{2}\frac{1}{2}$ ;  $\bar{u}0\frac{1}{2}$ ;  $\frac{1}{2}-u, 0, \frac{1}{2}$ ;  $u+\frac{1}{2}, \frac{1}{2}, \frac{1}{2}$ ;  
 $\bar{u}\frac{1}{2}\frac{1}{2}$ ;  $u0\frac{1}{2}$ ;  $u+\frac{1}{2}, 0, \frac{1}{2}$ ;  $\frac{1}{2}-u, \frac{1}{2}, \frac{1}{2}$ .  
(j)  $0u0$ ;  $\frac{1}{2}\bar{u}0$ ;  $\frac{1}{2}, \frac{1}{2}-u, 0$ ;  $0, u+\frac{1}{2}, 0$ ;  
 $0\bar{u}0$ ;  $\frac{1}{2}u0$ ;  $\frac{1}{2}, u+\frac{1}{2}, 0$ ;  $0, \frac{1}{2}-u, 0$ .  
(k)  $\frac{1}{2}u\frac{1}{2}$ ;  $0\bar{u}\frac{1}{2}$ ;  $0, \frac{1}{2}-u, \frac{1}{2}$ ;  $\frac{1}{2}, u+\frac{1}{2}, \frac{1}{2}$ ;  
 $\frac{1}{2}\bar{u}\frac{1}{2}$ ;  $0u\frac{1}{2}$ ;  $0, u+\frac{1}{2}, \frac{1}{2}$ ;  $\frac{1}{2}, \frac{1}{2}-u, \frac{1}{2}$ .  
(l)  $00u$ ;  $\frac{1}{2}0\bar{u}$ ;  $0\frac{1}{2}\bar{u}$ ;  $\frac{1}{2}\frac{1}{2}u$ ;  
 $00\bar{u}$ ;  $\frac{1}{2}0u$ ;  $0\frac{1}{2}u$ ;  $\frac{1}{2}\frac{1}{2}\bar{u}$ .  
(m)  $\frac{1}{2}uv$ ;  $\frac{1}{2}u\bar{v}$ ;  $\frac{1}{2}, u+\frac{1}{2}, v$ ;  $\frac{1}{2}, u+\frac{1}{2}, \bar{v}$ ;  
 $\frac{1}{2}\bar{u}v$ ;  $\frac{1}{2}\bar{u}\bar{v}$ ;  $\frac{1}{2}, \frac{1}{2}-u, v$ ;  $\frac{1}{2}, \frac{1}{2}-u, \bar{v}$ .  
(n)  $u\frac{1}{2}v$ ;  $u\frac{1}{2}\bar{v}$ ;  $u+\frac{1}{2}, \frac{1}{2}, v$ ;  $u+\frac{1}{2}, \frac{1}{2}, \bar{v}$ ;  
 $\bar{u}\frac{1}{2}v$ ;  $\bar{u}\frac{1}{2}\bar{v}$ ;  $\frac{1}{2}-u, \frac{1}{2}, v$ ;  $\frac{1}{2}-u, \frac{1}{2}, \bar{v}$ .

Sixteen equivalent positions:

- (o)  $xyz$ ;  $x\bar{y}\bar{z}$ ;  $\bar{x}y\bar{z}$ ;  $\bar{x}\bar{y}z$ ;  
 $\frac{1}{2}-x, \bar{y}, \bar{z}$ ;  $\frac{1}{2}-x, y, z$ ;  $x+\frac{1}{2}, \bar{y}, z$ ;  $x+\frac{1}{2}, y, \bar{z}$ ;  
 $x+\frac{1}{2}, y+\frac{1}{2}, z$ ;  $x+\frac{1}{2}, \frac{1}{2}-y, \bar{z}$ ;  $\frac{1}{2}-x, y+\frac{1}{2}, \bar{z}$ ;  $\frac{1}{2}-x, \frac{1}{2}-y, z$ ;  
 $\bar{x}, \frac{1}{2}-y, \bar{z}$ ;  $\bar{x}, y+\frac{1}{2}, z$ ;  $x, \frac{1}{2}-y, z$ ;  $x, y+\frac{1}{2}, \bar{z}$ .

SPACE-GROUP  $V_{\frac{2}{h}}^{22}$ .*Four* equivalent positions:

(a)  $000$ ;  $\frac{1}{2}0\frac{1}{2}$ ;  $\frac{1}{2}\frac{1}{2}0$ ;  $0\frac{1}{2}\frac{1}{2}$ .

(b)  $\frac{1}{2}00$ ;  $00\frac{1}{2}$ ;  $0\frac{1}{2}0$ ;  $\frac{1}{2}\frac{1}{2}\frac{1}{2}$ .

*Eight* equivalent positions:

(c)  $\frac{1}{2}0\frac{1}{2}$ ;  $\frac{1}{2}0\frac{1}{2}$ ;  $\frac{1}{2}0\frac{1}{2}$ ;  $\frac{1}{2}0\frac{1}{2}$ ;

$\frac{1}{2}\frac{1}{2}\frac{1}{2}$ ;  $\frac{1}{2}\frac{1}{2}\frac{1}{2}$ ;  $\frac{1}{2}\frac{1}{2}\frac{1}{2}$ ;  $\frac{1}{2}\frac{1}{2}\frac{1}{2}$ .

(d)  $0\frac{1}{2}\frac{1}{2}$ ;  $0\frac{1}{2}\frac{1}{2}$ ;  $0\frac{1}{2}\frac{1}{2}$ ;  $0\frac{1}{2}\frac{1}{2}$ ;

$\frac{1}{2}\frac{1}{2}\frac{1}{2}$ ;  $\frac{1}{2}\frac{1}{2}\frac{1}{2}$ ;  $\frac{1}{2}\frac{1}{2}\frac{1}{2}$ ;  $\frac{1}{2}\frac{1}{2}\frac{1}{2}$ .

(e)  $u00$ ;  $u+\frac{1}{2}, 0, \frac{1}{2}$ ;  $u+\frac{1}{2}, \frac{1}{2}, 0$ ;  $u\frac{1}{2}\frac{1}{2}$ ;

$\bar{u}00$ ;  $\frac{1}{2}-u, 0, \frac{1}{2}$ ;  $\frac{1}{2}-u, \frac{1}{2}, 0$ ;  $\bar{u}\frac{1}{2}\frac{1}{2}$ .

(f)  $0u0$ ;  $0, u+\frac{1}{2}, \frac{1}{2}$ ;  $\frac{1}{2}, u+\frac{1}{2}, 0$ ;  $\frac{1}{2}u\frac{1}{2}$ ;

$0\bar{u}0$ ;  $0, \frac{1}{2}-u, \frac{1}{2}$ ;  $\frac{1}{2}, \frac{1}{2}-u, 0$ ;  $\frac{1}{2}\bar{u}\frac{1}{2}$ .

(g)  $00u$ ;  $0, \frac{1}{2}, u+\frac{1}{2}$ ;  $\frac{1}{2}, 0, u+\frac{1}{2}$ ;  $\frac{1}{2}\frac{1}{2}u$ ;

$00\bar{u}$ ;  $0, \frac{1}{2}, \frac{1}{2}-u$ ;  $\frac{1}{2}, 0, \frac{1}{2}-u$ ;  $\frac{1}{2}\frac{1}{2}\bar{u}$ .

(h)  $\frac{1}{2}\frac{1}{2}u$ ;  $\frac{1}{2}\frac{1}{2}\bar{u}$ ;  $\frac{1}{2}, \frac{1}{2}, \frac{1}{2}-u$ ;  $\frac{1}{2}, \frac{1}{2}, u+\frac{1}{2}$ ;

$\frac{1}{2}\frac{1}{2}u$ ;  $\frac{1}{2}\frac{1}{2}\bar{u}$ ;  $\frac{1}{2}, \frac{1}{2}, \frac{1}{2}-u$ ;  $\frac{1}{2}, \frac{1}{2}, u+\frac{1}{2}$ .

*Sixteen* equivalent positions:

(i)  $xyz$ ;  $xy\bar{z}$ ;  $\bar{x}yz$ ;  $\bar{x}\bar{y}z$ ;  
 $\frac{1}{2}-x, \bar{y}, \frac{1}{2}-z$ ;  $\frac{1}{2}-x, y, z+\frac{1}{2}$ ;  $x+\frac{1}{2}, \bar{y}, z+\frac{1}{2}$ ;  $x+\frac{1}{2}, y, \frac{1}{2}-z$ ;  
 $x+\frac{1}{2}, y+\frac{1}{2}, z$ ;  $x+\frac{1}{2}, \frac{1}{2}-y, \bar{z}$ ;  $\frac{1}{2}-x, y+\frac{1}{2}, \bar{z}$ ;  $\frac{1}{2}-x, \frac{1}{2}-y, z$ ;  
 $\bar{x}, \frac{1}{2}-y, \frac{1}{2}-z$ ;  $\bar{x}, y+\frac{1}{2}, z+\frac{1}{2}$ ;  $x, \frac{1}{2}-y, z+\frac{1}{2}$ ;  $x, y+\frac{1}{2}, \frac{1}{2}-z$ .

SPACE-GROUP  $V_{\frac{2}{h}}^{23}$ .*Four* equivalent positions:

(a)  $000$ ;  $\frac{1}{2}\frac{1}{2}0$ ;  $\frac{1}{2}0\frac{1}{2}$ ;  $0\frac{1}{2}\frac{1}{2}$ .

(b)  $\frac{1}{2}00$ ;  $0\frac{1}{2}0$ ;  $00\frac{1}{2}$ ;  $\frac{1}{2}\frac{1}{2}\frac{1}{2}$ .

*Eight* equivalent positions:

(c)  $0\frac{1}{2}\frac{1}{2}$ ;  $0\frac{1}{2}\frac{1}{2}$ ;  $0\frac{1}{2}\frac{1}{2}$ ;  $0\frac{1}{2}\frac{1}{2}$ ;

$\frac{1}{2}\frac{1}{2}\frac{1}{2}$ ;  $\frac{1}{2}\frac{1}{2}\frac{1}{2}$ ;  $\frac{1}{2}\frac{1}{2}\frac{1}{2}$ ;  $\frac{1}{2}\frac{1}{2}\frac{1}{2}$ .

(d)  $\frac{1}{2}0\frac{1}{2}$ ;  $\frac{1}{2}0\frac{1}{2}$ ;  $\frac{1}{2}0\frac{1}{2}$ ;  $\frac{1}{2}0\frac{1}{2}$ ;

$\frac{1}{2}\frac{1}{2}\frac{1}{2}$ ;  $\frac{1}{2}\frac{1}{2}\frac{1}{2}$ ;  $\frac{1}{2}\frac{1}{2}\frac{1}{2}$ ;  $\frac{1}{2}\frac{1}{2}\frac{1}{2}$ .

(e)  $\frac{1}{2}\frac{1}{2}0$ ;  $\frac{1}{2}\frac{1}{2}0$ ;  $\frac{1}{2}\frac{1}{2}0$ ;  $\frac{1}{2}\frac{1}{2}0$ ;

$\frac{1}{2}\frac{1}{2}\frac{1}{2}$ ;  $\frac{1}{2}\frac{1}{2}\frac{1}{2}$ ;  $\frac{1}{2}\frac{1}{2}\frac{1}{2}$ ;  $\frac{1}{2}\frac{1}{2}\frac{1}{2}$ .

(f)  $\frac{1}{2}\frac{1}{2}\frac{1}{2}$ ;  $\frac{1}{2}\frac{1}{2}\frac{1}{2}$ ;  $\frac{1}{2}\frac{1}{2}\frac{1}{2}$ ;  $\frac{1}{2}\frac{1}{2}\frac{1}{2}$ ;

$\frac{1}{2}\frac{1}{2}\frac{1}{2}$ ;  $\frac{1}{2}\frac{1}{2}\frac{1}{2}$ ;  $\frac{1}{2}\frac{1}{2}\frac{1}{2}$ ;  $\frac{1}{2}\frac{1}{2}\frac{1}{2}$ .

(g)  $u00$ ;  $u+\frac{1}{2}, 0, \frac{1}{2}$ ;  $u+\frac{1}{2}, \frac{1}{2}, 0$ ;  $u\frac{1}{2}\frac{1}{2}$ ;

$\bar{u}00$ ;  $\frac{1}{2}-u, 0, \frac{1}{2}$ ;  $\frac{1}{2}-u, \frac{1}{2}, 0$ ;  $\bar{u}\frac{1}{2}\frac{1}{2}$ .

(h)  $0u0$ ;  $0, u+\frac{1}{2}, \frac{1}{2}$ ;  $\frac{1}{2}, u+\frac{1}{2}, 0$ ;  $\frac{1}{2}u\frac{1}{2}$ ;

$0\bar{u}0$ ;  $0, \frac{1}{2}-u, \frac{1}{2}$ ;  $\frac{1}{2}, \frac{1}{2}-u, 0$ ;  $\frac{1}{2}\bar{u}\frac{1}{2}$ .

(i)  $00u$ ;  $0, \frac{1}{2}, u+\frac{1}{2}$ ;  $\frac{1}{2}, 0, u+\frac{1}{2}$ ;  $\frac{1}{2}\frac{1}{2}u$ ;

$00\bar{u}$ ;  $0, \frac{1}{2}, \frac{1}{2}-u$ ;  $\frac{1}{2}, 0, \frac{1}{2}-u$ ;  $\frac{1}{2}\frac{1}{2}\bar{u}$ .

SPACE-GROUP  $V_{\frac{2}{2}}^{22}$  (continued).

Sixteen equivalent positions:

- (j)  $\frac{1}{2} \frac{1}{2} u$ ;  $\frac{1}{2} \frac{2}{2} u$ ;  $\frac{1}{2}, \frac{1}{2}, u+\frac{1}{2}$ ;  $\frac{1}{2}, \frac{2}{2}, u+\frac{1}{2}$ ;  
 $\frac{2}{2} \frac{2}{2} \bar{u}$ ;  $\frac{2}{2} \frac{1}{2} \bar{u}$ ;  $\frac{2}{2}, \frac{2}{2}, \frac{1}{2}-u$ ;  $\frac{2}{2}, \frac{1}{2}, \frac{1}{2}-u$ ;  
 $\frac{2}{2} \frac{2}{2} u$ ;  $\frac{2}{2} \frac{1}{2} u$ ;  $\frac{2}{2}, \frac{2}{2}, u+\frac{1}{2}$ ;  $\frac{2}{2}, \frac{1}{2}, u+\frac{1}{2}$ ;  
 $\frac{1}{2} \frac{1}{2} \bar{u}$ ;  $\frac{1}{2} \frac{2}{2} \bar{u}$ ;  $\frac{1}{2}, \frac{1}{2}, \frac{1}{2}-u$ ;  $\frac{1}{2}, \frac{2}{2}, \frac{1}{2}-u$ .
- (k)  $\frac{1}{2} u \frac{1}{2}$ ;  $\frac{1}{2} u \frac{2}{2}$ ;  $\frac{1}{2}, u+\frac{1}{2}, \frac{1}{2}$ ;  $\frac{1}{2}, u+\frac{1}{2}, \frac{2}{2}$ ;  
 $\frac{2}{2} \bar{u} \frac{2}{2}$ ;  $\frac{2}{2} \bar{u} \frac{1}{2}$ ;  $\frac{2}{2}, \frac{1}{2}-u, \frac{2}{2}$ ;  $\frac{2}{2}, \frac{1}{2}-u, \frac{1}{2}$ ;  
 $\frac{2}{2} u \frac{2}{2}$ ;  $\frac{2}{2} u \frac{1}{2}$ ;  $\frac{2}{2}, u+\frac{1}{2}, \frac{2}{2}$ ;  $\frac{2}{2}, u+\frac{1}{2}, \frac{1}{2}$ ;  
 $\frac{1}{2} \bar{u} \frac{1}{2}$ ;  $\frac{1}{2} \bar{u} \frac{2}{2}$ ;  $\frac{1}{2}, \frac{1}{2}-u, \frac{1}{2}$ ;  $\frac{1}{2}, \frac{1}{2}-u, \frac{2}{2}$ .
- (l)  $u \frac{1}{2} \frac{1}{2}$ ;  $u \frac{1}{2} \frac{2}{2}$ ;  $u+\frac{1}{2}, \frac{1}{2}, \frac{1}{2}$ ;  $u+\frac{1}{2}, \frac{1}{2}, \frac{2}{2}$ ;  
 $\bar{u} \frac{2}{2} \frac{2}{2}$ ;  $\bar{u} \frac{2}{2} \frac{1}{2}$ ;  $\frac{1}{2}-u, \frac{2}{2}, \frac{2}{2}$ ;  $\frac{1}{2}-u, \frac{2}{2}, \frac{1}{2}$ ;  
 $u \frac{2}{2} \frac{2}{2}$ ;  $u \frac{2}{2} \frac{1}{2}$ ;  $u+\frac{1}{2}, \frac{2}{2}, \frac{2}{2}$ ;  $u+\frac{1}{2}, \frac{2}{2}, \frac{1}{2}$ ;  
 $\bar{u} \frac{1}{2} \frac{1}{2}$ ;  $\bar{u} \frac{1}{2} \frac{2}{2}$ ;  $\frac{1}{2}-u, \frac{1}{2}, \frac{1}{2}$ ;  $\frac{1}{2}-u, \frac{1}{2}, \frac{2}{2}$ .
- (m)  $0 u v$ ;  $0, u+\frac{1}{2}, v+\frac{1}{2}$ ;  $\frac{1}{2}, u+\frac{1}{2}, v$ ;  $\frac{1}{2}, u, v+\frac{1}{2}$ ;  
 $0 \bar{u} \bar{v}$ ;  $0, \frac{1}{2}-u, \frac{1}{2}-v$ ;  $\frac{1}{2}, \frac{1}{2}-u, \bar{v}$ ;  $\frac{1}{2}, \bar{u}, \frac{1}{2}-v$ ;  
 $0 u \bar{v}$ ;  $0, u+\frac{1}{2}, \frac{1}{2}-v$ ;  $\frac{1}{2}, u+\frac{1}{2}, \bar{v}$ ;  $\frac{1}{2}, u, \frac{1}{2}-v$ ;  
 $0 \bar{u} v$ ;  $0, \frac{1}{2}-u, v+\frac{1}{2}$ ;  $\frac{1}{2}, \frac{1}{2}-u, v$ ;  $\frac{1}{2}, \bar{u}, v+\frac{1}{2}$ .
- (n)  $u 0 v$ ;  $u+\frac{1}{2}, 0, v+\frac{1}{2}$ ;  $u+\frac{1}{2}, \frac{1}{2}, v$ ;  $u, \frac{1}{2}, v+\frac{1}{2}$ ;  
 $u 0 \bar{v}$ ;  $u+\frac{1}{2}, 0, \frac{1}{2}-v$ ;  $u+\frac{1}{2}, \frac{1}{2}, \bar{v}$ ;  $u, \frac{1}{2}, \frac{1}{2}-v$ ;  
 $\bar{u} 0 \bar{v}$ ;  $\frac{1}{2}-u, 0, \frac{1}{2}-v$ ;  $\frac{1}{2}-u, \frac{1}{2}, \bar{v}$ ;  $\bar{u}, \frac{1}{2}, \frac{1}{2}-v$ ;  
 $\bar{u} 0 v$ ;  $\frac{1}{2}-u, 0, v+\frac{1}{2}$ ;  $\frac{1}{2}-u, \frac{1}{2}, v$ ;  $\bar{u}, \frac{1}{2}, v+\frac{1}{2}$ .
- (o)  $u v 0$ ;  $u+\frac{1}{2}, v+\frac{1}{2}, 0$ ;  $u+\frac{1}{2}, v, \frac{1}{2}$ ;  $u, v+\frac{1}{2}, \frac{1}{2}$ ;  
 $u \bar{v} 0$ ;  $u+\frac{1}{2}, \frac{1}{2}-v, 0$ ;  $u+\frac{1}{2}, \bar{v}, \frac{1}{2}$ ;  $u, \frac{1}{2}-v, \frac{1}{2}$ ;  
 $\bar{u} v 0$ ;  $\frac{1}{2}-u, v+\frac{1}{2}, 0$ ;  $\frac{1}{2}-u, v, \frac{1}{2}$ ;  $\bar{u}, v+\frac{1}{2}, \frac{1}{2}$ ;  
 $\bar{u} \bar{v} 0$ ;  $\frac{1}{2}-u, \frac{1}{2}-v, 0$ ;  $\frac{1}{2}-u, \bar{v}, \frac{1}{2}$ ;  $\bar{u}, \frac{1}{2}-v, \frac{1}{2}$ .

Thirty-two equivalent positions:

- (p)  $xyz$ ;  $x\bar{y}\bar{z}$ ;  $\bar{x}y\bar{z}$ ;  $\bar{x}\bar{y}z$ ;  
 $x\bar{y}\bar{z}$ ;  $\bar{x}yz$ ;  $x\bar{y}z$ ;  $xy\bar{z}$ ;  
 $x+\frac{1}{2}, y+\frac{1}{2}, z$ ;  $x+\frac{1}{2}, \frac{1}{2}-y, \bar{z}$ ;  $\frac{1}{2}-x, y+\frac{1}{2}, \bar{z}$ ;  $\frac{1}{2}-x, \frac{1}{2}-y, z$ ;  
 $\frac{1}{2}-x, \frac{1}{2}-y, \bar{z}$ ;  $\frac{1}{2}-x, y+\frac{1}{2}, z$ ;  $x+\frac{1}{2}, \frac{1}{2}-y, z$ ;  $x+\frac{1}{2}, y+\frac{1}{2}, \bar{z}$ ;  
 $x+\frac{1}{2}, y, z+\frac{1}{2}$ ;  $x+\frac{1}{2}, \bar{y}, \frac{1}{2}-z$ ;  $\frac{1}{2}-x, y, \frac{1}{2}-z$ ;  $\frac{1}{2}-x, \bar{y}, z+\frac{1}{2}$ ;  
 $\frac{1}{2}-x, \bar{y}, \frac{1}{2}-z$ ;  $\frac{1}{2}-x, y, z+\frac{1}{2}$ ;  $x+\frac{1}{2}, \bar{y}, z+\frac{1}{2}$ ;  $x+\frac{1}{2}, y, \frac{1}{2}-z$ ;  
 $x, y+\frac{1}{2}, z+\frac{1}{2}$ ;  $x, \frac{1}{2}-y, \frac{1}{2}-z$ ;  $\bar{x}, y+\frac{1}{2}, \frac{1}{2}-z$ ;  $\bar{x}, \frac{1}{2}-y, z+\frac{1}{2}$ ;  
 $\bar{x}, \frac{1}{2}-y, \frac{1}{2}-z$ ;  $\bar{x}, y+\frac{1}{2}, z+\frac{1}{2}$ ;  $x, \frac{1}{2}-y, z+\frac{1}{2}$ ;  $x, y+\frac{1}{2}, \frac{1}{2}-z$ .

SPACE-GROUP  $V_{\frac{2}{2}}^{24}$ .

Eight equivalent positions:

- (a)  $0 0 0$ ;  $\frac{1}{2} \frac{1}{2} 0$ ;  $\frac{1}{2} 0 \frac{1}{2}$ ;  $0 \frac{1}{2} \frac{1}{2}$ ;  
 $\frac{1}{2} \frac{1}{2} \frac{1}{2}$ ;  $\frac{2}{2} \frac{2}{2} \frac{1}{2}$ ;  $\frac{2}{2} \frac{1}{2} \frac{2}{2}$ ;  $\frac{1}{2} \frac{2}{2} \frac{2}{2}$ .
- (b)  $\frac{1}{2} 0 0$ ;  $0 \frac{1}{2} 0$ ;  $0 0 \frac{1}{2}$ ;  $\frac{1}{2} \frac{1}{2} \frac{1}{2}$ ;  
 $\frac{2}{2} \frac{1}{2} \frac{1}{2}$ ;  $\frac{1}{2} \frac{2}{2} \frac{1}{2}$ ;  $\frac{1}{2} \frac{1}{2} \frac{2}{2}$ ;  $\frac{2}{2} \frac{2}{2} \frac{2}{2}$ .

SPACE-GROUP  $V_n^{24}$  (continued).

Sixteen equivalent positions:

- (c)  $\frac{1}{2}\frac{1}{2}\frac{1}{2}$ ;  $\frac{1}{2}\frac{1}{2}\frac{1}{2}$ ;  $\frac{1}{2}\frac{1}{2}\frac{1}{2}$ ;  $\frac{1}{2}\frac{1}{2}\frac{1}{2}$ ;  
 $\frac{1}{2}\frac{1}{2}\frac{1}{2}$ ;  $\frac{1}{2}\frac{1}{2}\frac{1}{2}$ ;  $\frac{1}{2}\frac{1}{2}\frac{1}{2}$ ;  $\frac{1}{2}\frac{1}{2}\frac{1}{2}$ ;  
 $\frac{1}{2}\frac{1}{2}\frac{1}{2}$ ;  $\frac{1}{2}\frac{1}{2}\frac{1}{2}$ ;  $\frac{1}{2}\frac{1}{2}\frac{1}{2}$ ;  $\frac{1}{2}\frac{1}{2}\frac{1}{2}$ ;  
 $\frac{1}{2}\frac{1}{2}\frac{1}{2}$ ;  $\frac{1}{2}\frac{1}{2}\frac{1}{2}$ ;  $\frac{1}{2}\frac{1}{2}\frac{1}{2}$ ;  $\frac{1}{2}\frac{1}{2}\frac{1}{2}$ .
- (d)  $\frac{1}{2}\frac{1}{2}\frac{1}{2}$ ;  $\frac{1}{2}\frac{1}{2}\frac{1}{2}$ ;  $\frac{1}{2}\frac{1}{2}\frac{1}{2}$ ;  $\frac{1}{2}\frac{1}{2}\frac{1}{2}$ ;  
 $\frac{1}{2}\frac{1}{2}\frac{1}{2}$ ;  $\frac{1}{2}\frac{1}{2}\frac{1}{2}$ ;  $\frac{1}{2}\frac{1}{2}\frac{1}{2}$ ;  $\frac{1}{2}\frac{1}{2}\frac{1}{2}$ ;  
 $\frac{1}{2}\frac{1}{2}\frac{1}{2}$ ;  $\frac{1}{2}\frac{1}{2}\frac{1}{2}$ ;  $\frac{1}{2}\frac{1}{2}\frac{1}{2}$ ;  $\frac{1}{2}\frac{1}{2}\frac{1}{2}$ ;  
 $\frac{1}{2}\frac{1}{2}\frac{1}{2}$ ;  $\frac{1}{2}\frac{1}{2}\frac{1}{2}$ ;  $\frac{1}{2}\frac{1}{2}\frac{1}{2}$ ;  $\frac{1}{2}\frac{1}{2}\frac{1}{2}$ .
- (e)  $u00$ ;  $u+\frac{1}{2}, 0, \frac{1}{2}$ ;  $u+\frac{1}{2}, \frac{1}{2}, \frac{1}{2}$ ;  $u+\frac{1}{2}, \frac{1}{2}, \frac{1}{2}$ ;  
 $\bar{u}00$ ;  $\frac{1}{2}-u, 0, \frac{1}{2}$ ;  $\frac{1}{2}-u, \frac{1}{2}, \frac{1}{2}$ ;  $\frac{1}{2}-u, \frac{1}{2}, \frac{1}{2}$ ;  
 $u\frac{1}{2}\frac{1}{2}$ ;  $u+\frac{1}{2}, \frac{1}{2}, 0$ ;  $u+\frac{1}{2}, \frac{1}{2}, \frac{1}{2}$ ;  $u+\frac{1}{2}, \frac{1}{2}, \frac{1}{2}$ ;  
 $\bar{u}\frac{1}{2}\frac{1}{2}$ ;  $\frac{1}{2}-u, \frac{1}{2}, 0$ ;  $\frac{1}{2}-u, \frac{1}{2}, \frac{1}{2}$ ;  $\frac{1}{2}-u, \frac{1}{2}, \frac{1}{2}$ .
- (f)  $0u0$ ;  $0, u+\frac{1}{2}, \frac{1}{2}$ ;  $\frac{1}{2}, u+\frac{1}{2}, \frac{1}{2}$ ;  $\frac{1}{2}, u+\frac{1}{2}, \frac{1}{2}$ ;  
 $0\bar{u}0$ ;  $0, \frac{1}{2}-u, \frac{1}{2}$ ;  $\frac{1}{2}, \frac{1}{2}-u, \frac{1}{2}$ ;  $\frac{1}{2}, \frac{1}{2}-u, \frac{1}{2}$ ;  
 $\frac{1}{2}u\frac{1}{2}$ ;  $\frac{1}{2}, u+\frac{1}{2}, 0$ ;  $\frac{1}{2}, u+\frac{1}{2}, \frac{1}{2}$ ;  $\frac{1}{2}, u+\frac{1}{2}, \frac{1}{2}$ ;  
 $\frac{1}{2}\bar{u}\frac{1}{2}$ ;  $\frac{1}{2}, \frac{1}{2}-u, 0$ ;  $\frac{1}{2}, \frac{1}{2}-u, \frac{1}{2}$ ;  $\frac{1}{2}, \frac{1}{2}-u, \frac{1}{2}$ .
- (g)  $00u$ ;  $0, \frac{1}{2}, u+\frac{1}{2}$ ;  $\frac{1}{2}, \frac{1}{2}, u+\frac{1}{2}$ ;  $\frac{1}{2}, \frac{1}{2}, u+\frac{1}{2}$ ;  
 $00\bar{u}$ ;  $0, \frac{1}{2}, \frac{1}{2}-u$ ;  $\frac{1}{2}, \frac{1}{2}, \frac{1}{2}-u$ ;  $\frac{1}{2}, \frac{1}{2}, \frac{1}{2}-u$ ;  
 $\frac{1}{2}\frac{1}{2}u$ ;  $\frac{1}{2}, 0, u+\frac{1}{2}$ ;  $\frac{1}{2}, \frac{1}{2}, u+\frac{1}{2}$ ;  $\frac{1}{2}, \frac{1}{2}, u+\frac{1}{2}$ ;  
 $\frac{1}{2}\frac{1}{2}\bar{u}$ ;  $\frac{1}{2}, 0, \frac{1}{2}-u$ ;  $\frac{1}{2}, \frac{1}{2}, \frac{1}{2}-u$ ;  $\frac{1}{2}, \frac{1}{2}, \frac{1}{2}-u$ .

Thirty-two equivalent positions:

- (h)  $xyz$ ;  $x\bar{y}\bar{z}$ ;  $\bar{x}y\bar{z}$ ;  $\bar{x}\bar{y}z$ ;  
 $\frac{1}{2}-x, \frac{1}{2}-y, \frac{1}{2}-z$ ;  $\frac{1}{2}-x, y+\frac{1}{2}, z+\frac{1}{2}$ ;  $x+\frac{1}{2}, \frac{1}{2}-y, z+\frac{1}{2}$ ;  
 $x+\frac{1}{2}, y+\frac{1}{2}, \frac{1}{2}-z$ ;  
 $x+\frac{1}{2}, y+\frac{1}{2}, z$ ;  $x+\frac{1}{2}, \frac{1}{2}-y, \bar{z}$ ;  $\frac{1}{2}-x, y+\frac{1}{2}, \bar{z}$ ;  $\frac{1}{2}-x, \frac{1}{2}-y, z$ ;  
 $\frac{1}{2}-x, \frac{1}{2}-y, \frac{1}{2}-z$ ;  $\frac{1}{2}-x, y+\frac{1}{2}, z+\frac{1}{2}$ ;  $x+\frac{1}{2}, \frac{1}{2}-y, z+\frac{1}{2}$ ;  
 $x+\frac{1}{2}, y+\frac{1}{2}, \frac{1}{2}-z$ ;  
 $x+\frac{1}{2}, y, z+\frac{1}{2}$ ;  $x+\frac{1}{2}, \bar{y}, \frac{1}{2}-z$ ;  $\frac{1}{2}-x, y, \frac{1}{2}-z$ ;  $\frac{1}{2}-x, \bar{y}, z+\frac{1}{2}$ ;  
 $\frac{1}{2}-x, \frac{1}{2}-y, \frac{1}{2}-z$ ;  $\frac{1}{2}-x, y+\frac{1}{2}, z+\frac{1}{2}$ ;  $x+\frac{1}{2}, \frac{1}{2}-y, z+\frac{1}{2}$ ;  
 $x+\frac{1}{2}, y+\frac{1}{2}, \frac{1}{2}-z$ ;  
 $x, y+\frac{1}{2}, z+\frac{1}{2}$ ;  $x, \frac{1}{2}-y, \frac{1}{2}-z$ ;  $\bar{x}, y+\frac{1}{2}, \frac{1}{2}-z$ ;  $\bar{x}, \frac{1}{2}-y, z+\frac{1}{2}$ ;  
 $\frac{1}{2}-x, \frac{1}{2}-y, \frac{1}{2}-z$ ;  $\frac{1}{2}-x, y+\frac{1}{2}, z+\frac{1}{2}$ ;  $x+\frac{1}{2}, \frac{1}{2}-y, z+\frac{1}{2}$ ;  
 $x+\frac{1}{2}, y+\frac{1}{2}, \frac{1}{2}-z$ .

SPACE-GROUP  $V_n^{25}$ .

Two equivalent positions:

- (a)  $000$ ;  $\frac{1}{2}\frac{1}{2}\frac{1}{2}$ . (c)  $00\frac{1}{2}$ ;  $\frac{1}{2}\frac{1}{2}0$ .  
 (b)  $\frac{1}{2}00$ ;  $0\frac{1}{2}\frac{1}{2}$ . (d)  $\frac{1}{2}0\frac{1}{2}$ ;  $0\frac{1}{2}0$ .

Four equivalent positions:

- (e)  $u00$ ;  $\bar{u}00$ ;  $u+\frac{1}{2}, \frac{1}{2}, \frac{1}{2}$ ;  $\frac{1}{2}-u, \frac{1}{2}, \frac{1}{2}$ .  
 (f)  $u0\frac{1}{2}$ ;  $\bar{u}0\frac{1}{2}$ ;  $u+\frac{1}{2}, \frac{1}{2}, 0$ ;  $\frac{1}{2}-u, \frac{1}{2}, 0$ .  
 (g)  $0u0$ ;  $0\bar{u}0$ ;  $\frac{1}{2}, u+\frac{1}{2}, \frac{1}{2}$ ;  $\frac{1}{2}, \frac{1}{2}-u, \frac{1}{2}$ .  
 (h)  $0u\frac{1}{2}$ ;  $0\bar{u}\frac{1}{2}$ ;  $\frac{1}{2}, u+\frac{1}{2}, 0$ ;  $\frac{1}{2}, \frac{1}{2}-u, 0$ .  
 (i)  $00u$ ;  $00\bar{u}$ ;  $\frac{1}{2}, \frac{1}{2}, u+\frac{1}{2}$ ;  $\frac{1}{2}, \frac{1}{2}, \frac{1}{2}-u$ .  
 (j)  $0\frac{1}{2}u$ ;  $0\frac{1}{2}\bar{u}$ ;  $\frac{1}{2}, 0, u+\frac{1}{2}$ ;  $\frac{1}{2}, 0, \frac{1}{2}-u$ .

SPACE-GROUP  $V_h^{25}$  (continued).

Eight equivalent positions:

- (k)  $\frac{1}{2} \frac{1}{2} \frac{1}{2}$ ;  $\frac{1}{2} \frac{2}{2} \frac{2}{2}$ ;  $\frac{2}{2} \frac{1}{2} \frac{1}{2}$ ;  $\frac{2}{2} \frac{2}{2} \frac{1}{2}$ ;  
 $\frac{2}{2} \frac{2}{2} \frac{2}{2}$ ;  $\frac{2}{2} \frac{1}{2} \frac{1}{2}$ ;  $\frac{1}{2} \frac{2}{2} \frac{1}{2}$ ;  $\frac{1}{2} \frac{1}{2} \frac{2}{2}$ .  
 (l)  $0 u v$ ;  $0 u \bar{v}$ ;  $\frac{1}{2}, u + \frac{1}{2}, v + \frac{1}{2}$ ;  $\frac{1}{2}, u + \frac{1}{2}, \frac{1}{2} - v$ ;  
 $0 \bar{u} v$ ;  $0 \bar{u} \bar{v}$ ;  $\frac{1}{2}, \frac{1}{2} - u, \frac{1}{2} - v$ ;  $\frac{1}{2}, \frac{1}{2} - u, v + \frac{1}{2}$ .  
 (m)  $u 0 v$ ;  $u 0 \bar{v}$ ;  $u + \frac{1}{2}, \frac{1}{2}, v + \frac{1}{2}$ ;  $u + \frac{1}{2}, \frac{1}{2}, \frac{1}{2} - v$ ;  
 $\bar{u} 0 v$ ;  $\bar{u} 0 \bar{v}$ ;  $\frac{1}{2} - u, \frac{1}{2}, \frac{1}{2} - v$ ;  $\frac{1}{2} - u, \frac{1}{2}, v + \frac{1}{2}$ .  
 (n)  $u v 0$ ;  $u \bar{v} 0$ ;  $u + \frac{1}{2}, v + \frac{1}{2}, \frac{1}{2}$ ;  $u + \frac{1}{2}, \frac{1}{2} - v, \frac{1}{2}$ ;  
 $\bar{u} \bar{v} 0$ ;  $\bar{u} v 0$ ;  $\frac{1}{2} - u, \frac{1}{2} - v, \frac{1}{2}$ ;  $\frac{1}{2} - u, v + \frac{1}{2}, \frac{1}{2}$ .

Sixteen equivalent positions:

- (o)  $xyz$ ;  $x\bar{y}\bar{z}$ ;  $\bar{x}y\bar{z}$ ;  $\bar{x}\bar{y}z$ ;  
 $\bar{x}\bar{y}\bar{z}$ ;  $\bar{x}yz$ ;  $x\bar{y}z$ ;  $xy\bar{z}$ ;  
 $x + \frac{1}{2}, y + \frac{1}{2}, z + \frac{1}{2}$ ;  $x + \frac{1}{2}, \frac{1}{2} - y, \frac{1}{2} - z$ ;  $\frac{1}{2} - x, y + \frac{1}{2}, \frac{1}{2} - z$ ;  
 $\frac{1}{2} - x, \frac{1}{2} - y, z + \frac{1}{2}$ ;  
 $\frac{1}{2} - x, \frac{1}{2} - y, \frac{1}{2} - z$ ;  $\frac{1}{2} - x, y + \frac{1}{2}, z + \frac{1}{2}$ ;  $x + \frac{1}{2}, \frac{1}{2} - y, z + \frac{1}{2}$ ;  
 $x + \frac{1}{2}, y + \frac{1}{2}, \frac{1}{2} - z$ .

SPACE-GROUP  $V_h^{26}$ .

Four equivalent positions:

- (a)  $0 0 0$ ;  $0 0 \frac{1}{2}$ ;  $\frac{1}{2} \frac{1}{2} \frac{1}{2}$ ;  $\frac{1}{2} \frac{1}{2} 0$ .  
 (b)  $\frac{1}{2} 0 0$ ;  $\frac{1}{2} 0 \frac{1}{2}$ ;  $0 \frac{1}{2} \frac{1}{2}$ ;  $0 \frac{1}{2} 0$ .  
 (c)  $0 0 \frac{1}{2}$ ;  $0 0 \frac{1}{2}$ ;  $\frac{1}{2} \frac{1}{2} \frac{1}{2}$ ;  $\frac{1}{2} \frac{1}{2} \frac{1}{2}$ .  
 (d)  $0 \frac{1}{2} \frac{1}{2}$ ;  $0 \frac{1}{2} \frac{1}{2}$ ;  $\frac{1}{2} 0 \frac{1}{2}$ ;  $\frac{1}{2} 0 \frac{1}{2}$ .

Eight equivalent positions:

- (e)  $\frac{1}{2} \frac{1}{2} 0$ ;  $\frac{1}{2} \frac{2}{2} 0$ ;  $\frac{2}{2} \frac{1}{2} 0$ ;  $\frac{2}{2} \frac{2}{2} 0$ ;  
 $\frac{2}{2} \frac{2}{2} \frac{1}{2}$ ;  $\frac{2}{2} \frac{1}{2} \frac{1}{2}$ ;  $\frac{1}{2} \frac{2}{2} \frac{1}{2}$ ;  $\frac{1}{2} \frac{1}{2} \frac{1}{2}$ .  
 (f)  $u 0 0$ ;  $u 0 \frac{1}{2}$ ;  $u + \frac{1}{2}, \frac{1}{2}, 0$ ;  $u + \frac{1}{2}, \frac{1}{2}, \frac{1}{2}$ ;  
 $\bar{u} 0 0$ ;  $\bar{u} 0 \frac{1}{2}$ ;  $\frac{1}{2} - u, \frac{1}{2}, 0$ ;  $\frac{1}{2} - u, \frac{1}{2}, \frac{1}{2}$ .  
 (g)  $0 u 0$ ;  $0 u \frac{1}{2}$ ;  $\frac{1}{2}, u + \frac{1}{2}, 0$ ;  $\frac{1}{2}, u + \frac{1}{2}, \frac{1}{2}$ ;  
 $0 \bar{u} 0$ ;  $0 \bar{u} \frac{1}{2}$ ;  $\frac{1}{2}, \frac{1}{2} - u, 0$ ;  $\frac{1}{2}, \frac{1}{2} - u, \frac{1}{2}$ .  
 (h)  $0 0 u$ ;  $\frac{1}{2} \frac{1}{2} u$ ;  $\frac{1}{2}, \frac{1}{2}, u + \frac{1}{2}$ ;  $0, 0, u + \frac{1}{2}$ ;  
 $0 0 \bar{u}$ ;  $\frac{1}{2} \frac{1}{2} \bar{u}$ ;  $\frac{1}{2}, \frac{1}{2}, \frac{1}{2} - u$ ;  $0, 0, \frac{1}{2} - u$ .  
 (i)  $0 \frac{1}{2} u$ ;  $\frac{1}{2} 0 u$ ;  $\frac{1}{2}, 0, u + \frac{1}{2}$ ;  $0, \frac{1}{2}, u + \frac{1}{2}$ ;  
 $0 \frac{1}{2} \bar{u}$ ;  $\frac{1}{2} 0 \bar{u}$ ;  $\frac{1}{2}, 0, \frac{1}{2} - u$ ;  $0, \frac{1}{2}, \frac{1}{2} - u$ .  
 (j)  $u v \frac{1}{2}$ ;  $u \bar{v} \frac{1}{2}$ ;  $u + \frac{1}{2}, \frac{1}{2} - v, \frac{1}{2}$ ;  $u + \frac{1}{2}, v + \frac{1}{2}, \frac{1}{2}$ ;  
 $\bar{u} \bar{v} \frac{1}{2}$ ;  $\bar{u} v \frac{1}{2}$ ;  $\frac{1}{2} - u, v + \frac{1}{2}, \frac{1}{2}$ ;  $\frac{1}{2} - u, \frac{1}{2} - v, \frac{1}{2}$ .

Sixteen equivalent positions:

- (k)  $xyz$ ;  $x\bar{y}\bar{z}$ ;  $\bar{x}y\bar{z}$ ;  $\bar{x}\bar{y}z$ ;  
 $\bar{x}, \bar{y}, \frac{1}{2} - z$ ;  $\bar{x}, y, z + \frac{1}{2}$ ;  $x, \bar{y}, z + \frac{1}{2}$ ;  $x, y, \frac{1}{2} - z$ ;  
 $x + \frac{1}{2}, y + \frac{1}{2}, z + \frac{1}{2}$ ;  $x + \frac{1}{2}, \frac{1}{2} - y, \frac{1}{2} - z$ ;  $\frac{1}{2} - x, y + \frac{1}{2}, \frac{1}{2} - z$ ;  
 $\frac{1}{2} - x, \frac{1}{2} - y, z + \frac{1}{2}$ ;  
 $\frac{1}{2} - x, \frac{1}{2} - y, \bar{z}$ ;  $\frac{1}{2} - x, y + \frac{1}{2}, z$ ;  $x + \frac{1}{2}, \frac{1}{2} - y, z$ ;  $x + \frac{1}{2}, y + \frac{1}{2}, \bar{z}$ .

SPACE-GROUP  $V_h^7$  (continued).

By shifting the origin of coordinates to the point  $\left(\frac{\tau_x}{2}\right)$  of this first set, these positions become:

Two equivalent positions:

- (a)  $000$ ;  $\frac{1}{2}0\frac{1}{2}$ .                      (c)  $0\frac{1}{2}\frac{1}{2}$ ;  $\frac{1}{2}\frac{1}{2}0$ .  
 (b)  $\frac{1}{2}00$ ;  $00\frac{1}{2}$ .                      (d)  $\frac{1}{2}\frac{1}{2}\frac{1}{2}$ ;  $0\frac{1}{2}0$ .

Four equivalent positions:

- (e)  $u00$ ;  $\bar{u}00$ ;  $\frac{1}{2}-u, 0, \frac{1}{2}$ ;  $u+\frac{1}{2}, 0, \frac{1}{2}$ .  
 (f)  $u\frac{1}{2}\frac{1}{2}$ ;  $\bar{u}\frac{1}{2}\frac{1}{2}$ ;  $\frac{1}{2}-u, \frac{1}{2}, 0$ .  $u+\frac{1}{2}, \frac{1}{2}, 0$ .  
 (g)  $\frac{1}{2}u\frac{1}{2}$ ;  $\frac{1}{2}\bar{u}\frac{1}{2}$ ;  $\frac{1}{2}\bar{u}\frac{1}{2}$ ;  $\frac{1}{2}u\frac{1}{2}$ .  
 (h)  $0uv$ ;  $0\bar{u}\bar{v}$ ;  $\frac{1}{2}, u, \frac{1}{2}-v$ ;  $\frac{1}{2}, \bar{u}, v+\frac{1}{2}$ .

Eight equivalent positions:

- (i)  $xyz$ ;  $x\bar{y}\bar{z}$ ;  $\frac{1}{2}-x, y, \frac{1}{2}-z$ ;  $\frac{1}{2}-x, \bar{y}, z+\frac{1}{2}$ ;  
 $\bar{x}\bar{y}\bar{z}$ ;  $\bar{x}yz$ ;  $x+\frac{1}{2}, \bar{y}, z+\frac{1}{2}$ ;  $x+\frac{1}{2}, y, \frac{1}{2}-z$ .

SPACE-GROUP  $V_h^8$ .

Four equivalent positions:

- (a)  $0\frac{1}{2}0$ ;  $0\frac{1}{2}0$ ;  $0\frac{1}{2}\frac{1}{2}$ ;  $0\frac{1}{2}\frac{1}{2}$ .  
 (b)  $\frac{1}{2}\frac{1}{2}\frac{1}{2}$ ;  $\frac{1}{2}\frac{1}{2}\frac{1}{2}$ ;  $\frac{1}{2}\frac{1}{2}0$ ;  $\frac{1}{2}\frac{1}{2}0$ .  
 (c)  $u00$ ;  $\bar{u}0\frac{1}{2}$ ;  $\bar{u}\frac{1}{2}0$ ;  $u\frac{1}{2}\frac{1}{2}$ .  
 (d)  $0u\frac{1}{2}$ ;  $0\bar{u}\frac{1}{2}$ ;  $0, \frac{1}{2}-u, \frac{1}{2}$ ;  $0, u+\frac{1}{2}, \frac{1}{2}$ .  
 (e)  $\frac{1}{2}u\frac{1}{2}$ ;  $\frac{1}{2}\bar{u}\frac{1}{2}$ ;  $\frac{1}{2}, \frac{1}{2}-u, \frac{1}{2}$ ;  $\frac{1}{2}, u+\frac{1}{2}, \frac{1}{2}$ .

Eight equivalent positions:

- (f)  $xyz$ ;  $x\bar{y}\bar{z}$ ;  $\bar{x}, y, \frac{1}{2}-z$ ;  $\bar{x}, \bar{y}, z+\frac{1}{2}$ ;  
 $\bar{x}, \frac{1}{2}-y, \bar{z}$ ;  $\bar{x}, y+\frac{1}{2}, z$ ;  $x, \frac{1}{2}-y, z+\frac{1}{2}$ ;  $x, y+\frac{1}{2}, \frac{1}{2}-z$ .

The *unique* cases can be simplified by transferring the origin to the point  $\left(\frac{\tau_y}{2}\right)$ .

SPACE-GROUP  $V_h^9$ .

Two equivalent positions:

- (a)  $000$ ;  $\frac{1}{2}\frac{1}{2}0$ .                      (c)  $0\frac{1}{2}0$ ;  $\frac{1}{2}00$ .  
 (b)  $00\frac{1}{2}$ ;  $\frac{1}{2}\frac{1}{2}\frac{1}{2}$ .                      (d)  $0\frac{1}{2}\frac{1}{2}$ ;  $\frac{1}{2}0\frac{1}{2}$ .

Four equivalent positions:

- (e)  $00u$ ;  $00\bar{u}$ ;  $\frac{1}{2}\frac{1}{2}\bar{u}$ ;  $\frac{1}{2}\frac{1}{2}u$ .  
 (f)  $0\frac{1}{2}u$ ;  $0\frac{1}{2}\bar{u}$ ;  $\frac{1}{2}0\bar{u}$ ;  $\frac{1}{2}0u$ .  
 (g)  $uv0$ ;  $\bar{u}\bar{v}0$ ;  $u+\frac{1}{2}, \frac{1}{2}-v, 0$ ;  $\frac{1}{2}-u, v+\frac{1}{2}, 0$ .  
 (h)  $uv\frac{1}{2}$ ;  $\bar{u}\bar{v}\frac{1}{2}$ ;  $u+\frac{1}{2}, \frac{1}{2}-v, \frac{1}{2}$ ;  $\frac{1}{2}-u, v+\frac{1}{2}, \frac{1}{2}$ .

Eight equivalent positions:

- (i)  $xyz$ ;  $x+\frac{1}{2}, \frac{1}{2}-y, \bar{z}$ ;  $\frac{1}{2}-x, y+\frac{1}{2}, \bar{z}$ ;  $\bar{x}\bar{y}\bar{z}$ ;  
 $\bar{x}\bar{y}\bar{z}$ ;  $\frac{1}{2}-x, y+\frac{1}{2}, z$ ;  $x+\frac{1}{2}, \frac{1}{2}-y, z$ ;  $xy\bar{z}$ .

SPACE-GROUP  $V_h^{10}$ .

Four equivalent positions:

- (a)  $\frac{1}{2} \frac{1}{2} \frac{1}{2}$ ;  $\frac{3}{2} \frac{1}{2} \frac{3}{2}$ ;  $\frac{1}{2} \frac{3}{2} \frac{3}{2}$ ;  $\frac{3}{2} \frac{3}{2} \frac{1}{2}$ .  
 (b)  $\frac{3}{2} \frac{3}{2} \frac{3}{2}$ ;  $\frac{1}{2} \frac{3}{2} \frac{1}{2}$ ;  $\frac{3}{2} \frac{1}{2} \frac{1}{2}$ ;  $\frac{1}{2} \frac{1}{2} \frac{3}{2}$ .  
 (c)  $00u$ ;  $\frac{1}{2} \frac{1}{2} \bar{u}$ ;  $\frac{1}{2}$ ,  $\frac{1}{2}$ ,  $\frac{1}{2}-u$ ;  $0, 0, u+\frac{1}{2}$ .  
 (d)  $0 \frac{1}{2} u$ ;  $\frac{1}{2} 0 \bar{u}$ ;  $\frac{1}{2}$ ,  $0$ ,  $\frac{1}{2}-u$ ;  $0, \frac{1}{2}, u+\frac{1}{2}$ .

Eight equivalent positions:

- (e)  $xyz$ ;  $x+\frac{1}{2}, \frac{1}{2}-y, \bar{z}$ ;  $\frac{1}{2}-x, y+\frac{1}{2}, \bar{z}$ ;  $\bar{x}\bar{y}z$ ;  
 $\frac{1}{2}-x, \frac{1}{2}-y, \frac{1}{2}-z$ ;  $\bar{x}, y, z+\frac{1}{2}$ ;  $x, \bar{y}, z+\frac{1}{2}$ ;  $\frac{1}{2}-x, \frac{1}{2}-y, z+\frac{1}{2}$ .

By shifting the origin to  $\left(\frac{\tau_x}{2}, \frac{\tau_y}{2}, \frac{\tau_z}{2}\right)$  the *uniquely* placed arrangements can be slightly simplified.

SPACE-GROUP  $V_h^{11}$ .

Four equivalent positions:

- (a)  $0 \frac{1}{2} 0$ ;  $\frac{1}{2} \frac{1}{2} 0$ ;  $\frac{1}{2} \frac{3}{2} 0$ ;  $0 \frac{3}{2} 0$ .  
 (b)  $0 \frac{1}{2} \frac{1}{2}$ ;  $\frac{1}{2} \frac{1}{2} \frac{1}{2}$ ;  $\frac{1}{2} \frac{3}{2} \frac{1}{2}$ ;  $0 \frac{3}{2} \frac{1}{2}$ .  
 (c)  $00u$ ;  $\frac{1}{2} \frac{1}{2} \bar{u}$ ;  $0 \frac{1}{2} \bar{u}$ ;  $\frac{1}{2} 0 u$ .  
 (d)  $\frac{1}{2} u v$ ;  $\frac{3}{2} \bar{u} v$ ;  $\frac{3}{2}$ ,  $\frac{1}{2}-u$ ,  $\bar{v}$ ;  $\frac{1}{2}$ ,  $u+\frac{1}{2}$ ,  $\bar{v}$ .

Eight equivalent positions:

- (e)  $xyz$ ;  $x+\frac{1}{2}, \frac{1}{2}-y, \bar{z}$ ;  $\frac{1}{2}-x, y+\frac{1}{2}, \bar{z}$ ;  $\bar{x}\bar{y}z$ ;  
 $\bar{x}, \frac{1}{2}-y, \bar{z}$ ;  $\frac{1}{2}-x, y, z$ ;  $x+\frac{1}{2}, \bar{y}, z$ ;  $x, y+\frac{1}{2}, \bar{z}$ .

The *unique* cases can be simplified by placing the origin at the point  $\left(\frac{\tau_y}{2}\right)$ .

SPACE-GROUP  $V_h^{12}$ .

Two equivalent positions:

- (a)  $00\frac{1}{2}$ ;  $\frac{1}{2}\frac{1}{2}\frac{3}{2}$ . (c)  $0\frac{1}{2}\frac{1}{2}$ ;  $\frac{1}{2}0\frac{3}{2}$ .  
 (b)  $00\frac{3}{2}$ ;  $\frac{1}{2}\frac{1}{2}\frac{1}{2}$ . (d)  $0\frac{1}{2}\frac{3}{2}$ ;  $\frac{1}{2}0\frac{1}{2}$ .

Four equivalent positions:

- (e)  $00u$ ;  $\frac{1}{2}\frac{1}{2}\bar{u}$ ;  $\frac{1}{2}, \frac{1}{2}, u+\frac{1}{2}$ ;  $0, 0, \frac{1}{2}-u$ .  
 (f)  $0\frac{1}{2}u$ ;  $\frac{1}{2}0\bar{u}$ ;  $\frac{1}{2}, 0, u+\frac{1}{2}$ ;  $0, \frac{1}{2}, \frac{1}{2}-u$ .  
 (g)  $uv\frac{1}{2}$ ;  $\bar{u}\bar{v}\frac{1}{2}$ ;  $u+\frac{1}{2}, \frac{1}{2}-v, \frac{3}{2}$ ;  $\frac{1}{2}-u, v+\frac{1}{2}, \frac{3}{2}$ .

Eight equivalent positions:

- (h)  $xyz$ ;  $x+\frac{1}{2}, \frac{1}{2}-y, \bar{z}$ ;  $\frac{1}{2}-x, y+\frac{1}{2}, \bar{z}$ ;  $\bar{x}\bar{y}z$ ;  
 $\bar{x}, \bar{y}, \frac{1}{2}-z$ ;  $\frac{1}{2}-x, y+\frac{1}{2}, z+\frac{1}{2}$ ;  $x+\frac{1}{2}, \frac{1}{2}-y, z+\frac{1}{2}$ ;  $x, y, \frac{1}{2}-z$ .

The *unique* cases can be simplified by changing the origin to  $\left(\frac{\tau_z}{2}\right)$ .

SPACE-GROUP  $V_h^{13}$ .

Two equivalent positions:

- (a)  $00u$ ;  $\frac{1}{2}\frac{1}{2}\bar{u}$ . (b)  $0\frac{1}{2}u$ ;  $\frac{1}{2}0\bar{u}$ .



SPACE-GROUP  $V_4^0$  (continued).

Sixteen equivalent positions:

$$\begin{aligned}
 (j) \quad & xyz; & x\bar{y}\bar{z}; & \bar{x}yz; & \bar{x}\bar{y}z; \\
 & y, x, z+\frac{1}{2}; & \bar{y}, x, \frac{1}{2}-z; & y, \bar{x}, \frac{1}{2}-z; & \bar{y}, \bar{x}, z+\frac{1}{2}; \\
 & x+\frac{1}{2}, y+\frac{1}{2}, z; & x+\frac{1}{2}, \frac{1}{2}-y, \bar{z}; & \frac{1}{2}-x, y+\frac{1}{2}, \bar{z}; & \frac{1}{2}-x, \frac{1}{2}-y, z; \\
 & y+\frac{1}{2}, x+\frac{1}{2}, z+\frac{1}{2}; & \frac{1}{2}-y, x+\frac{1}{2}, \frac{1}{2}-z; & y+\frac{1}{2}, \frac{1}{2}-x, \frac{1}{2}-z; & \frac{1}{2}-y, \frac{1}{2}-x, z+\frac{1}{2}.
 \end{aligned}$$

SPACE-GROUP  $V_4^{1*}$ 

Four equivalent positions:

$$\begin{aligned}
 (a) \quad & 000; & \frac{1}{2}00; & \frac{1}{2}\frac{1}{2}0; & 0\frac{1}{2}0. \\
 (b) \quad & \frac{1}{2}\frac{1}{2}\frac{1}{2}; & 0\frac{1}{2}\frac{1}{2}; & 00\frac{1}{2}; & \frac{1}{2}0\frac{1}{2}. \\
 (c) \quad & \frac{1}{2}\frac{1}{2}0; & \frac{1}{2}\frac{1}{2}0; & \frac{1}{2}\frac{1}{2}0; & \frac{1}{2}\frac{1}{2}0. \\
 (d) \quad & \frac{1}{2}\frac{1}{2}\frac{1}{2}; & \frac{1}{2}\frac{1}{2}\frac{1}{2}; & \frac{1}{2}\frac{1}{2}\frac{1}{2}; & \frac{1}{2}\frac{1}{2}\frac{1}{2}.
 \end{aligned}$$

Eight equivalent positions:

$$\begin{aligned}
 (e) \quad & 00u; & 00\bar{u}; & \frac{1}{2}0u; & \frac{1}{2}0\bar{u}; \\
 & \frac{1}{2}\frac{1}{2}u; & \frac{1}{2}\frac{1}{2}\bar{u}; & 0\frac{1}{2}u; & 0\frac{1}{2}\bar{u}. \\
 (f) \quad & \frac{1}{2}\frac{1}{2}u; & \frac{1}{2}\frac{1}{2}\bar{u}; & \frac{1}{2}\frac{1}{2}u; & \frac{1}{2}\frac{1}{2}\bar{u}; \\
 & \frac{1}{2}\frac{1}{2}\bar{u}; & \frac{1}{2}\frac{1}{2}\bar{u}; & \frac{1}{2}\frac{1}{2}\bar{u}; & \frac{1}{2}\frac{1}{2}u. \\
 (g) \quad & \frac{1}{2}u0; & u\frac{1}{2}0; & \frac{1}{2}\bar{u}0; & \bar{u}\frac{1}{2}0; \\
 & \frac{1}{2}-u, \frac{1}{2}, 0; & u+\frac{1}{2}, \frac{1}{2}, 0; & \frac{1}{2}, u+\frac{1}{2}, 0; & \frac{1}{2}, \frac{1}{2}-u, 0. \\
 (h) \quad & \frac{1}{2}u\frac{1}{2}; & u\frac{1}{2}\frac{1}{2}; & \frac{1}{2}\bar{u}\frac{1}{2}; & \bar{u}\frac{1}{2}\frac{1}{2}; \\
 & \frac{1}{2}-u, \frac{1}{2}, \frac{1}{2}; & u+\frac{1}{2}, \frac{1}{2}, \frac{1}{2}; & \frac{1}{2}, u+\frac{1}{2}, \frac{1}{2}; & \frac{1}{2}, \frac{1}{2}-u, \frac{1}{2}.
 \end{aligned}$$

Sixteen equivalent positions:

$$\begin{aligned}
 (i) \quad & xyz; & y\bar{x}\bar{z}; & \bar{x}\bar{y}z; & \bar{y}\bar{x}z; \\
 & \frac{1}{2}-x, y, \bar{z}; & \frac{1}{2}-y, \bar{x}, z; & x+\frac{1}{2}, \bar{y}, \bar{z}; & y+\frac{1}{2}, x, z; \\
 & x+\frac{1}{2}, y+\frac{1}{2}, z; & y+\frac{1}{2}, \frac{1}{2}-x, \bar{z}; & \frac{1}{2}-x, \frac{1}{2}-y, z; & \frac{1}{2}-y, x+\frac{1}{2}, \bar{z}; \\
 & \bar{x}, y+\frac{1}{2}, \bar{z}; & \bar{y}, \frac{1}{2}-x, z; & x, \frac{1}{2}-y, \bar{z}; & y, x+\frac{1}{2}, z.
 \end{aligned}$$

SPACE-GROUP  $V_4^{2*}$ 

Four equivalent positions:

$$\begin{aligned}
 (a) \quad & 000; & \frac{1}{2}0\frac{1}{2}; & \frac{1}{2}\frac{1}{2}0; & 0\frac{1}{2}\frac{1}{2}. \\
 (b) \quad & \frac{1}{2}\frac{1}{2}\frac{1}{2}; & 0\frac{1}{2}0; & 00\frac{1}{2}; & \frac{1}{2}00. \\
 (c) \quad & \frac{1}{2}\frac{1}{2}\frac{1}{2}; & \frac{1}{2}\frac{1}{2}\frac{1}{2}; & \frac{1}{2}\frac{1}{2}\frac{1}{2}; & \frac{1}{2}\frac{1}{2}\frac{1}{2}. \\
 (d) \quad & \frac{1}{2}\frac{1}{2}\frac{1}{2}; & \frac{1}{2}\frac{1}{2}\frac{1}{2}; & \frac{1}{2}\frac{1}{2}\frac{1}{2}; & \frac{1}{2}\frac{1}{2}\frac{1}{2}.
 \end{aligned}$$

Eight equivalent positions:

$$\begin{aligned}
 (e) \quad & 00u; & 00\bar{u}; & \frac{1}{2}, 0, \frac{1}{2}-u; & \frac{1}{2}, 0, u+\frac{1}{2}; \\
 & \frac{1}{2}\frac{1}{2}u; & \frac{1}{2}\frac{1}{2}\bar{u}; & 0, \frac{1}{2}, \frac{1}{2}-u; & 0, \frac{1}{2}, u+\frac{1}{2}. \\
 (f) \quad & \frac{1}{2}u\frac{1}{2}; & u\frac{1}{2}\frac{1}{2}; & \frac{1}{2}\bar{u}\frac{1}{2}; & \bar{u}\frac{1}{2}\frac{1}{2}; \\
 & \frac{1}{2}-u, \frac{1}{2}, \frac{1}{2}; & u+\frac{1}{2}, \frac{1}{2}, \frac{1}{2}; & \frac{1}{2}, u+\frac{1}{2}, \frac{1}{2}; & \frac{1}{2}, \frac{1}{2}-u, \frac{1}{2}. \\
 (g) \quad & \frac{1}{2}u\frac{1}{2}; & u\frac{1}{2}\frac{1}{2}; & \frac{1}{2}\bar{u}\frac{1}{2}; & \bar{u}\frac{1}{2}\frac{1}{2}; \\
 & \frac{1}{2}-u, \frac{1}{2}, \frac{1}{2}; & u+\frac{1}{2}, \frac{1}{2}, \frac{1}{2}; & \frac{1}{2}, u+\frac{1}{2}, \frac{1}{2}; & \frac{1}{2}, \frac{1}{2}-u, \frac{1}{2}. \\
 (h) \quad & \frac{1}{2}\frac{1}{2}u; & \frac{1}{2}\frac{1}{2}\bar{u}; & \frac{1}{2}\frac{1}{2}u; & \frac{1}{2}\frac{1}{2}\bar{u}; \\
 & \frac{1}{2}, \frac{1}{2}, \frac{1}{2}-u; & \frac{1}{2}, \frac{1}{2}, u+\frac{1}{2}; & \frac{1}{2}, \frac{1}{2}, \frac{1}{2}-u; & \frac{1}{2}, \frac{1}{2}, u+\frac{1}{2}.
 \end{aligned}$$

SPACE-GROUP  $V_d^8$  (continued).

Sixteen equivalent positions:

- (i)  $xyz$ ;  $y\bar{x}\bar{z}$ ;  $\bar{x}y\bar{z}$ ;  $\bar{y}x\bar{z}$ ;  
 $\frac{1}{2}-x, y, \frac{1}{2}-z$ ;  $\frac{1}{2}-y, \bar{x}, z+\frac{1}{2}$ ;  $x+\frac{1}{2}, \bar{y}, \frac{1}{2}-z$ ;  $y+\frac{1}{2}, x, z+\frac{1}{2}$ ;  
 $x+\frac{1}{2}, y+\frac{1}{2}, z$ ;  $y+\frac{1}{2}, \frac{1}{2}-x, \bar{z}$ ;  $\frac{1}{2}-x, \frac{1}{2}-y, z$ ;  $\frac{1}{2}-y, x+\frac{1}{2}, \bar{z}$ ;  
 $\bar{x}, y+\frac{1}{2}, \frac{1}{2}-z$ ;  $\bar{y}, \frac{1}{2}-x, z+\frac{1}{2}$ ;  $x, \frac{1}{2}-y, \frac{1}{2}-z$ ;  $y, x+\frac{1}{2}, z+\frac{1}{2}$ .

SPACE-GROUP  $V_d^9$ .

Four equivalent positions:

- (a)  $000$ ;  $\frac{1}{2}\frac{1}{2}0$ ;  $\frac{1}{2}0\frac{1}{2}$ ;  $0\frac{1}{2}\frac{1}{2}$ .  
 (b)  $\frac{1}{2}00$ ;  $0\frac{1}{2}0$ ;  $00\frac{1}{2}$ ;  $\frac{1}{2}\frac{1}{2}\frac{1}{2}$ .  
 (c)  $\frac{1}{2}\frac{1}{2}\frac{1}{2}$ ;  $\frac{1}{2}\frac{1}{2}\frac{1}{2}$ ;  $\frac{1}{2}\frac{1}{2}\frac{1}{2}$ ;  $\frac{1}{2}\frac{1}{2}\frac{1}{2}$ .  
 (d)  $\frac{1}{2}\frac{1}{2}\frac{1}{2}$ ;  $\frac{1}{2}\frac{1}{2}\frac{1}{2}$ ;  $\frac{1}{2}\frac{1}{2}\frac{1}{2}$ ;  $\frac{1}{2}\frac{1}{2}\frac{1}{2}$ .

Eight equivalent positions:

- (e)  $00u$ ;  $\frac{1}{2}\frac{1}{2}u$ ;  $\frac{1}{2}, 0, u+\frac{1}{2}$ ;  $0, \frac{1}{2}, u+\frac{1}{2}$ ;  
 $00\bar{u}$ ;  $\frac{1}{2}\frac{1}{2}\bar{u}$ ;  $\frac{1}{2}, 0, \frac{1}{2}-u$ ;  $0, \frac{1}{2}, \frac{1}{2}-u$ .  
 (f)  $\frac{1}{2}\frac{1}{2}u$ ;  $\frac{1}{2}\frac{1}{2}\bar{u}$ ;  $\frac{1}{2}, \frac{1}{2}, \frac{1}{2}-u$ ;  $\frac{1}{2}, \frac{1}{2}, u+\frac{1}{2}$ ;  
 $\frac{1}{2}\frac{1}{2}u$ ;  $\frac{1}{2}\frac{1}{2}\bar{u}$ ;  $\frac{1}{2}, \frac{1}{2}, \frac{1}{2}-u$ ;  $\frac{1}{2}, \frac{1}{2}, u+\frac{1}{2}$ .

Sixteen equivalent positions:

- (g)  $u00$ ;  $u\frac{1}{2}\frac{1}{2}$ ;  $u+\frac{1}{2}, \frac{1}{2}, 0$ ;  $u+\frac{1}{2}, 0, \frac{1}{2}$ ;  
 $\bar{u}00$ ;  $\bar{u}\frac{1}{2}\frac{1}{2}$ ;  $\frac{1}{2}-u, \frac{1}{2}, 0$ ;  $\frac{1}{2}-u, 0, \frac{1}{2}$ ;  
 $0u0$ ;  $\frac{1}{2}u\frac{1}{2}$ ;  $\frac{1}{2}, u+\frac{1}{2}, 0$ ;  $0, u+\frac{1}{2}, \frac{1}{2}$ ;  
 $0\bar{u}0$ ;  $\frac{1}{2}\bar{u}\frac{1}{2}$ ;  $\frac{1}{2}, \frac{1}{2}-u, 0$ ;  $0, \frac{1}{2}-u, \frac{1}{2}$ .  
 (h)  $\frac{1}{2}u\frac{1}{2}$ ;  $\bar{u}\frac{1}{2}\frac{1}{2}$ ;  $\frac{1}{2}, \frac{1}{2}-u, \frac{1}{2}$ ;  $u+\frac{1}{2}, \frac{1}{2}, \frac{1}{2}$ ;  
 $u\frac{1}{2}\frac{1}{2}$ ;  $\bar{u}\frac{1}{2}\frac{1}{2}$ ;  $\frac{1}{2}-u, \frac{1}{2}, \frac{1}{2}$ ;  $u+\frac{1}{2}, \frac{1}{2}, \frac{1}{2}$ ;  
 $u\frac{1}{2}\frac{1}{2}$ ;  $\frac{1}{2}\bar{u}\frac{1}{2}$ ;  $\frac{1}{2}-u, \frac{1}{2}, \frac{1}{2}$ ;  $\frac{1}{2}, u+\frac{1}{2}, \frac{1}{2}$ ;  
 $\frac{1}{2}u\frac{1}{2}$ ;  $\frac{1}{2}\bar{u}\frac{1}{2}$ ;  $\frac{1}{2}, \frac{1}{2}-u, \frac{1}{2}$ ;  $\frac{1}{2}, u+\frac{1}{2}, \frac{1}{2}$ .  
 (i)  $uu\bar{v}$ ;  $u+\frac{1}{2}, u+\frac{1}{2}, \bar{v}$ ;  $u+\frac{1}{2}, u, \bar{v}+\frac{1}{2}$ ;  $u, u+\frac{1}{2}, \bar{v}+\frac{1}{2}$ ;  
 $u\bar{u}\bar{v}$ ;  $u+\frac{1}{2}, \frac{1}{2}-u, \bar{v}$ ;  $u+\frac{1}{2}, \bar{u}, \frac{1}{2}-\bar{v}$ ;  $u, \frac{1}{2}-u, \frac{1}{2}-\bar{v}$ ;  
 $\bar{u}u\bar{v}$ ;  $\frac{1}{2}-u, u+\frac{1}{2}, \bar{v}$ ;  $\frac{1}{2}-u, u, \frac{1}{2}-\bar{v}$ ;  $\bar{u}, u+\frac{1}{2}, \frac{1}{2}-\bar{v}$ ;  
 $\bar{u}\bar{u}\bar{v}$ ;  $\frac{1}{2}-u, \frac{1}{2}-u, \bar{v}$ ;  $\frac{1}{2}-u, \bar{u}, \bar{v}+\frac{1}{2}$ ;  $\bar{u}, \frac{1}{2}-u, \bar{v}+\frac{1}{2}$ .

Thirty-two equivalent positions:

- (j)  $xyz$ ;  $x\bar{y}\bar{z}$ ;  $\bar{x}y\bar{z}$ ;  $\bar{y}x\bar{z}$ ;  
 $yxz$ ;  $\bar{y}\bar{x}\bar{z}$ ;  $y\bar{x}\bar{z}$ ;  $\bar{y}\bar{x}z$ ;  
 $x+\frac{1}{2}, y+\frac{1}{2}, z$ ;  $x+\frac{1}{2}, \frac{1}{2}-y, \bar{z}$ ;  $\frac{1}{2}-x, y+\frac{1}{2}, \bar{z}$ ;  $\frac{1}{2}-x, \frac{1}{2}-y, z$ ;  
 $y+\frac{1}{2}, x+\frac{1}{2}, z$ ;  $\frac{1}{2}-y, x+\frac{1}{2}, \bar{z}$ ;  $y+\frac{1}{2}, \frac{1}{2}-x, \bar{z}$ ;  $\frac{1}{2}-y, \frac{1}{2}-x, z$ ;  
 $x+\frac{1}{2}, y, z+\frac{1}{2}$ ;  $x+\frac{1}{2}, \bar{y}, \frac{1}{2}-z$ ;  $\frac{1}{2}-x, y, \frac{1}{2}-z$ ;  $\frac{1}{2}-x, \bar{y}, z+\frac{1}{2}$ ;  
 $y+\frac{1}{2}, x, z+\frac{1}{2}$ ;  $\frac{1}{2}-y, x, \frac{1}{2}-z$ ;  $y+\frac{1}{2}, \bar{x}, \frac{1}{2}-z$ ;  $\frac{1}{2}-y, \bar{x}, z+\frac{1}{2}$ ;  
 $x, y+\frac{1}{2}, z+\frac{1}{2}$ ;  $x, \frac{1}{2}-y, \frac{1}{2}-z$ ;  $\bar{x}, y+\frac{1}{2}, \frac{1}{2}-z$ ;  $\bar{x}, \frac{1}{2}-y, z+\frac{1}{2}$ ;  
 $y, x+\frac{1}{2}, z+\frac{1}{2}$ ;  $\bar{y}, x+\frac{1}{2}, \frac{1}{2}-z$ ;  $y, \frac{1}{2}-x, \frac{1}{2}-z$ ;  $\bar{y}, \frac{1}{2}-x, z+\frac{1}{2}$ .

SPACE-GROUP  $V_d^{10}$ .

Eight equivalent positions:

- (a)  $000$ ;  $00\frac{1}{2}$ ;  $\frac{1}{2}\frac{1}{2}0$ ;  $\frac{1}{2}\frac{1}{2}\frac{1}{2}$ .  
 $\frac{1}{2}0\frac{1}{2}$ ;  $\frac{1}{2}00$ ;  $0\frac{1}{2}\frac{1}{2}$ ;  $0\frac{1}{2}0$ .

SPACE-GROUP  $V_d^{10}$  (continued).

- (b)  $00\frac{1}{2}$ ;  $00\frac{3}{2}$ ;  $\frac{1}{2}\frac{1}{2}\frac{1}{2}$ ;  $\frac{1}{2}\frac{1}{2}\frac{3}{2}$ ;  
 $\frac{3}{2}0\frac{1}{2}$ ;  $\frac{3}{2}0\frac{3}{2}$ ;  $0\frac{1}{2}\frac{1}{2}$ ;  $0\frac{1}{2}\frac{3}{2}$ .  
 (c)  $\frac{1}{2}\frac{1}{2}0$ ;  $\frac{1}{2}\frac{3}{2}0$ ;  $\frac{3}{2}\frac{1}{2}0$ ;  $\frac{3}{2}\frac{3}{2}0$ ;  
 $\frac{1}{2}\frac{1}{2}\frac{1}{2}$ ;  $\frac{3}{2}\frac{1}{2}\frac{1}{2}$ ;  $\frac{1}{2}\frac{3}{2}\frac{1}{2}$ ;  $\frac{3}{2}\frac{3}{2}\frac{1}{2}$ .  
 (d)  $\frac{1}{2}\frac{1}{2}\frac{1}{2}$ ;  $\frac{1}{2}\frac{3}{2}\frac{3}{2}$ ;  $\frac{3}{2}\frac{1}{2}\frac{3}{2}$ ;  $\frac{3}{2}\frac{3}{2}\frac{3}{2}$ ;  
 $\frac{1}{2}\frac{1}{2}\frac{3}{2}$ ;  $\frac{3}{2}\frac{1}{2}\frac{1}{2}$ ;  $\frac{1}{2}\frac{3}{2}\frac{1}{2}$ ;  $\frac{3}{2}\frac{3}{2}\frac{1}{2}$ .

## Sixteen equivalent positions:

- (e)  $u00$ ;  $0u\frac{1}{2}$ ;  $0, u+\frac{1}{2}, 0$ ;  $u+\frac{1}{2}, \frac{1}{2}, 0$ ;  
 $\bar{u}00$ ;  $0\bar{u}\frac{1}{2}$ ;  $0, \frac{1}{2}-u, 0$ ;  $\frac{1}{2}-u, \frac{1}{2}, 0$ ;  
 $u\frac{1}{2}\frac{1}{2}$ ;  $\frac{1}{2}u0$ ;  $\frac{1}{2}, u+\frac{1}{2}, \frac{1}{2}$ ;  $u+\frac{1}{2}, 0, \frac{1}{2}$ ;  
 $\bar{u}\frac{1}{2}\frac{1}{2}$ ;  $\frac{1}{2}\bar{u}0$ ;  $\frac{1}{2}, \frac{1}{2}-u, \frac{1}{2}$ ;  $\frac{1}{2}-u, 0, \frac{1}{2}$ .  
 (f)  $00u$ ;  $0\frac{1}{2}u$ ;  $0, \frac{1}{2}, u+\frac{1}{2}$ ;  $0, 0, u+\frac{1}{2}$ ;  
 $00\bar{u}$ ;  $0\frac{1}{2}\bar{u}$ ;  $0, \frac{1}{2}, \frac{1}{2}-u$ ;  $0, 0, \frac{1}{2}-u$ ;  
 $\frac{1}{2}\frac{1}{2}u$ ;  $\frac{1}{2}0u$ ;  $\frac{1}{2}, 0, u+\frac{1}{2}$ ;  $\frac{1}{2}, \frac{1}{2}, u+\frac{1}{2}$ ;  
 $\frac{1}{2}\frac{1}{2}\bar{u}$ ;  $\frac{1}{2}0\bar{u}$ ;  $\frac{1}{2}, 0, \frac{1}{2}-u$ ;  $\frac{1}{2}, \frac{1}{2}, \frac{1}{2}-u$ .  
 (g)  $\frac{1}{2}\frac{1}{2}u$ ;  $\frac{1}{2}\frac{3}{2}u$ ;  $\frac{1}{2}, \frac{1}{2}, u+\frac{1}{2}$ ;  $\frac{1}{2}, \frac{3}{2}, u+\frac{1}{2}$ ;  
 $\frac{1}{2}\frac{1}{2}\bar{u}$ ;  $\frac{1}{2}\frac{3}{2}\bar{u}$ ;  $\frac{1}{2}, \frac{1}{2}, \frac{1}{2}-u$ ;  $\frac{1}{2}, \frac{3}{2}, \frac{1}{2}-u$ ;  
 $\frac{3}{2}\frac{1}{2}u$ ;  $\frac{3}{2}\frac{3}{2}u$ ;  $\frac{3}{2}, \frac{3}{2}, u+\frac{1}{2}$ ;  $\frac{3}{2}, \frac{1}{2}, u+\frac{1}{2}$ ;  
 $\frac{3}{2}\frac{1}{2}\bar{u}$ ;  $\frac{3}{2}\frac{3}{2}\bar{u}$ ;  $\frac{3}{2}, \frac{3}{2}, \frac{1}{2}-u$ ;  $\frac{3}{2}, \frac{1}{2}, \frac{1}{2}-u$ .  
 (h)  $\frac{1}{2}u\frac{1}{2}$ ;  $\bar{u}\frac{1}{2}\frac{1}{2}$ ;  $\frac{1}{2}, \frac{1}{2}-u, \frac{1}{2}$ ;  $u+\frac{1}{2}, \frac{1}{2}, \frac{1}{2}$ ;  
 $\frac{1}{2}\bar{u}\frac{3}{2}$ ;  $u\frac{1}{2}\frac{3}{2}$ ;  $\frac{1}{2}, u+\frac{1}{2}, \frac{3}{2}$ ;  $\frac{1}{2}-u, \frac{1}{2}, \frac{3}{2}$ ;  
 $\frac{3}{2}\bar{u}\frac{1}{2}$ ;  $u\frac{3}{2}\frac{1}{2}$ ;  $\frac{3}{2}, u+\frac{1}{2}, \frac{1}{2}$ ;  $\frac{1}{2}-u, \frac{3}{2}, \frac{1}{2}$ ;  
 $\frac{3}{2}u\frac{3}{2}$ ;  $\bar{u}\frac{3}{2}\frac{3}{2}$ ;  $\frac{3}{2}, \frac{1}{2}-u, \frac{3}{2}$ ;  $u+\frac{1}{2}, \frac{3}{2}, \frac{3}{2}$ .

## Thirty-two equivalent positions:

- (i)  $xyz$ ;  $x\bar{y}\bar{z}$ ;  $\bar{x}yz$ ;  $\bar{x}\bar{y}z$ ;  
 $y, x, z+\frac{1}{2}$ ;  $\bar{y}, x, \frac{1}{2}-z$ ;  $y, \bar{x}, \frac{1}{2}-z$ ;  $\bar{y}, \bar{x}, z+\frac{1}{2}$ ;  
 $x+\frac{1}{2}, y+\frac{1}{2}, z$ ;  $x+\frac{1}{2}, \frac{1}{2}-y, \bar{z}$ ;  $\frac{1}{2}-x, y+\frac{1}{2}, \bar{z}$ ;  $\frac{1}{2}-x, \frac{1}{2}-y, z$ ;  
 $y+\frac{1}{2}, x+\frac{1}{2}, z+\frac{1}{2}$ ;  $\frac{1}{2}-y, x+\frac{1}{2}, \frac{1}{2}-z$ ;  $y+\frac{1}{2}, \frac{1}{2}-x, \frac{1}{2}-z$ ;  
 $\frac{1}{2}-y, \frac{1}{2}-x, z+\frac{1}{2}$ ;  
 $x+\frac{1}{2}, y, z+\frac{1}{2}$ ;  $x+\frac{1}{2}, \bar{y}, \frac{1}{2}-z$ ;  $\frac{1}{2}-x, y, \frac{1}{2}-z$ ;  $\frac{1}{2}-x, \bar{y}, z+\frac{1}{2}$ ;  
 $y+\frac{1}{2}, x, z$ ;  $\frac{1}{2}-y, x, \bar{z}$ ;  $y+\frac{1}{2}, \bar{x}, \bar{z}$ ;  $\frac{1}{2}-y, \bar{x}, z$ ;  
 $x, y+\frac{1}{2}, z+\frac{1}{2}$ ;  $x, \frac{1}{2}-y, \frac{1}{2}-z$ ;  $\bar{x}, y+\frac{1}{2}, \frac{1}{2}-z$ ;  $\bar{x}, \frac{1}{2}-y, z+\frac{1}{2}$ ;  
 $y, x+\frac{1}{2}, z$ ;  $\bar{y}, x+\frac{1}{2}, \bar{z}$ ;  $y, \frac{1}{2}-x, \bar{z}$ ;  $\bar{y}, \frac{1}{2}-x, z$ .

SPACE-GROUP  $V_d^{11}$ \*

## Two equivalent positions:

- (a)  $000$ ;  $\frac{1}{2}\frac{1}{2}\frac{1}{2}$ . (b)  $00\frac{1}{2}$ ;  $\frac{1}{2}\frac{1}{2}0$ .

## Four equivalent positions:

- (c)  $\frac{1}{2}00$ ;  $0\frac{1}{2}\frac{1}{2}$ ;  $0\frac{1}{2}0$ ;  $\frac{1}{2}0\frac{1}{2}$ .  
 (d)  $0\frac{1}{2}\frac{1}{2}$ ;  $0\frac{1}{2}\frac{3}{2}$ ;  $\frac{1}{2}0\frac{1}{2}$ ;  $\frac{1}{2}0\frac{3}{2}$ .  
 (e)  $00u$ ;  $00\bar{u}$ ;  $\frac{1}{2}, \frac{1}{2}, u+\frac{1}{2}$ ;  $\frac{1}{2}, \frac{1}{2}, \frac{1}{2}-u$ .

## Eight equivalent positions:

- (f)  $u00$ ;  $0u0$ ;  $u+\frac{1}{2}, \frac{1}{2}, \frac{1}{2}$ ;  $\frac{1}{2}, u+\frac{1}{2}, \frac{1}{2}$ ;  
 $\bar{u}00$ ;  $0\bar{u}0$ ;  $\frac{1}{2}-u, \frac{1}{2}, \frac{1}{2}$ ;  $\frac{1}{2}, \frac{1}{2}-u, \frac{1}{2}$ .

SPACE-GROUP  $V_d^{11}$  (continued).

- (g)  $u\ 0\ \frac{1}{2}$ ;  $0\ u\ \frac{1}{2}$ ;  $u+\frac{1}{2}, \frac{1}{2}, 0$ ;  $\frac{1}{2}, u+\frac{1}{2}, 0$ ;  
 $\bar{u}\ 0\ \frac{1}{2}$ ;  $0\ \bar{u}\ \frac{1}{2}$ ;  $\frac{1}{2}-u, \frac{1}{2}, 0$ ;  $\frac{1}{2}, \frac{1}{2}-u, 0$ .  
 (h)  $0\ \frac{1}{2}\ u$ ;  $\frac{1}{2}\ 0\ u$ ;  $0, \frac{1}{2}, u+\frac{1}{2}$ ;  $\frac{1}{2}, 0, u+\frac{1}{2}$ ;  
 $0\ \frac{1}{2}\ \bar{u}$ ;  $\frac{1}{2}\ 0\ \bar{u}$ ;  $0, \frac{1}{2}, \frac{1}{2}-u$ ;  $\frac{1}{2}, 0, \frac{1}{2}-u$ .  
 (i)  $u\ u\ v$ ;  $u\ \bar{u}\ v$ ;  $u+\frac{1}{2}, u+\frac{1}{2}, v+\frac{1}{2}$ ;  $u+\frac{1}{2}, \frac{1}{2}-u, \frac{1}{2}-v$ ;  
 $\bar{u}\ \bar{u}\ v$ ;  $\bar{u}\ u\ v$ ;  $\frac{1}{2}-u, \frac{1}{2}-u, v+\frac{1}{2}$ ;  $\frac{1}{2}-u, u+\frac{1}{2}, \frac{1}{2}-v$ .

Sixteen equivalent positions:

- (j)  $xyz$ ;  $x\bar{y}\bar{z}$ ;  $\bar{x}y\bar{z}$ ;  $\bar{x}\bar{y}z$ ;  
 $yxz$ ;  $\bar{y}x\bar{z}$ ;  $y\bar{x}\bar{z}$ ;  $\bar{y}\bar{x}z$ ;  
 $x+\frac{1}{2}, y+\frac{1}{2}, z+\frac{1}{2}$ ;  $x+\frac{1}{2}, \frac{1}{2}-y, \frac{1}{2}-z$ ;  $\frac{1}{2}-x, y+\frac{1}{2}, \frac{1}{2}-z$ ;  
 $\frac{1}{2}-x, \frac{1}{2}-y, z+\frac{1}{2}$ ;  
 $y+\frac{1}{2}, x+\frac{1}{2}, z+\frac{1}{2}$ ;  $\frac{1}{2}-y, x+\frac{1}{2}, \frac{1}{2}-z$ ;  $y+\frac{1}{2}, \frac{1}{2}-x, \frac{1}{2}-z$ ;  
 $\frac{1}{2}-y, \frac{1}{2}-x, z+\frac{1}{2}$ .

SPACE-GROUP  $V_d^{12*}$ .

Four equivalent positions:

- (a)  $0\ 0\ 0$ ;  $\frac{1}{2}\ 0\ \frac{1}{2}$ ;  $\frac{1}{2}\ \frac{1}{2}\ \frac{1}{2}$ ;  $0\ \frac{1}{2}\ \frac{1}{2}$ .  
 (b)  $0\ 0\ \frac{1}{2}$ ;  $\frac{1}{2}\ 0\ \frac{1}{2}$ ;  $\frac{1}{2}\ \frac{1}{2}\ 0$ ;  $0\ \frac{1}{2}\ \frac{1}{2}$ .

Eight equivalent positions

- (c)  $0\ 0\ u$ ;  $0\ 0\ \bar{u}$ ;  $\frac{1}{2}, 0, \frac{1}{2}-u$ ;  $\frac{1}{2}, 0, u+\frac{1}{2}$ ;  
 $\frac{1}{2}, \frac{1}{2}, u+\frac{1}{2}$ ;  $\frac{1}{2}, \frac{1}{2}, \frac{1}{2}-u$ ;  $0, \frac{1}{2}, \frac{1}{2}-u$ ;  $0, \frac{1}{2}, u+\frac{1}{2}$ .  
 (d)  $\frac{1}{2}\ u\ \frac{1}{2}$ ;  $u\ \frac{1}{2}\ \frac{1}{2}$ ;  $\frac{1}{2}\ \bar{u}\ \frac{1}{2}$ ;  $\bar{u}\ \frac{1}{2}\ \frac{1}{2}$ ;  
 $\frac{1}{2}, u+\frac{1}{2}, \frac{1}{2}$ ;  $u+\frac{1}{2}, \frac{1}{2}, \frac{1}{2}$ ;  $\frac{1}{2}, \frac{1}{2}-u, \frac{1}{2}$ ;  $\frac{1}{2}-u, \frac{1}{2}, \frac{1}{2}$ .

Sixteen equivalent positions:

- (e)  $xyz$ ;  $y\bar{x}\bar{z}$ ;  $\bar{x}y\bar{z}$ ;  $\bar{y}x\bar{z}$ ;  
 $\frac{1}{2}-x, y, \frac{1}{2}-z$ ;  $\frac{1}{2}-y, \bar{x}, z+\frac{1}{2}$ ;  $x+\frac{1}{2}, \bar{y}, \frac{1}{2}-z$ ;  $y+\frac{1}{2}, x, z+\frac{1}{2}$ ;  
 $x+\frac{1}{2}, y+\frac{1}{2}, z+\frac{1}{2}$ ;  $y+\frac{1}{2}, \frac{1}{2}-x, \frac{1}{2}-z$ ;  $\frac{1}{2}-x, \frac{1}{2}-y, z+\frac{1}{2}$ ;  
 $\frac{1}{2}-y, x+\frac{1}{2}, \frac{1}{2}-z$ ;  
 $\bar{x}, y+\frac{1}{2}, \frac{1}{2}-z$ ;  $\bar{y}, \frac{1}{2}-x, z+\frac{1}{2}$ ;  $x, \frac{1}{2}-y, \frac{1}{2}-z$ ;  $y, x+\frac{1}{2}, z+\frac{1}{2}$ .

C. TETARTOEDRY.

SPACE-GROUP  $C_4^1$ .

One equivalent position:

- (a)  $0\ 0\ u$ . (b)  $\frac{1}{2}\ \frac{1}{2}\ u$ .

Two equivalent positions:

- (c)  $0\ \frac{1}{2}\ u$ ;  $\frac{1}{2}\ 0\ u$ .

Four equivalent positions:

- (d)  $xyz$ ;  $\bar{y}xz$ ;  $\bar{x}\bar{y}z$ ;  $y\bar{x}z$ .

SPACE-GROUP  $C_4^2$ .

Four equivalent positions:

- (a)  $xyz$ ;  $\bar{y}, x, z+\frac{1}{2}$ ;  $\bar{x}, \bar{y}, z+\frac{1}{2}$ ;  $y, \bar{x}, z+\frac{1}{2}$ .

SPACE-GROUP  $C_4^3$ .*Two equivalent positions:*

- (a)  $00u$ ;  $0, 0, u+\frac{1}{2}$ .      (c)  $0\frac{1}{2}u$ ;  $\frac{1}{2}, 0, u+\frac{1}{2}$ .  
 (b)  $\frac{1}{2}\frac{1}{2}u$ ;  $\frac{1}{2}, \frac{1}{2}, u+\frac{1}{2}$ .

*Four equivalent positions:*

- (d)  $xyz$ ;  $\bar{y}, x, z+\frac{1}{2}$ ;  $\bar{x}\bar{y}z$ ;  $y, \bar{x}, z+\frac{1}{2}$ .

SPACE-GROUP  $C_4^4$ .*Four equivalent positions:*

- (a)  $xyz$ ;  $\bar{y}, x, z+\frac{1}{2}$ ;  $\bar{x}, \bar{y}, z+\frac{1}{2}$ ;  $y, \bar{x}, z+\frac{1}{2}$ .

SPACE-GROUP  $C_4^5$ .*Two equivalent positions:*

- (a)  $00u$ ;  $\frac{1}{2}, \frac{1}{2}, u+\frac{1}{2}$ .

*Four equivalent positions:*

- (b)  $0\frac{1}{2}u$ ;  $\frac{1}{2}0u$ ;  $\frac{1}{2}, 0, u+\frac{1}{2}$ ;  $0, \frac{1}{2}, u+\frac{1}{2}$ .

*Eight equivalent positions:*

- (c)  $xyz$ ;  $\bar{y}xz$ ;  $\bar{x}\bar{y}z$ ;  $y\bar{x}z$ ;  
 $x+\frac{1}{2}, y+\frac{1}{2}, z+\frac{1}{2}$ ;  $\frac{1}{2}-y, x+\frac{1}{2}, z+\frac{1}{2}$ ;  $\frac{1}{2}-x, \frac{1}{2}-y, z+\frac{1}{2}$ ;  
 $y+\frac{1}{2}, \frac{1}{2}-x, z+\frac{1}{2}$ .

SPACE-GROUP  $C_4^{6*}$ .*Four equivalent positions:*

- (a)  $00u$ ;  $0, \frac{1}{2}, u+\frac{1}{2}$ ;  $\frac{1}{2}, 0, u+\frac{1}{2}$ ;  $\frac{1}{2}, \frac{1}{2}, u+\frac{1}{2}$ .

*Eight equivalent positions:*

- (b)  $xyz$ ;  $y, \frac{1}{2}-x, z+\frac{1}{2}$ ;  $\bar{x}\bar{y}z$ ;  $\frac{1}{2}-y, x, z+\frac{1}{2}$ ;  
 $x+\frac{1}{2}, y+\frac{1}{2}, z+\frac{1}{2}$ ;  $y+\frac{1}{2}, \bar{x}, z+\frac{1}{2}$ ;  $\frac{1}{2}-x, \frac{1}{2}-y, z+\frac{1}{2}$ ;  
 $\bar{y}, x+\frac{1}{2}, z+\frac{1}{2}$ .

## D. PARAMORPHIC HEMIHEDRY.

SPACE-GROUP  $C_{4h}^1$ .*One equivalent position:*

- (a)  $000$ .      (b)  $00\frac{1}{2}$ .      (c)  $\frac{1}{2}\frac{1}{2}0$ .      (d)  $\frac{1}{2}\frac{1}{2}\frac{1}{2}$ .

*Two equivalent positions:*

- (e)  $0\frac{1}{2}0$ ;  $\frac{1}{2}00$ .      (g)  $00u$ ;  $00\bar{u}$ .  
 (f)  $0\frac{1}{2}\frac{1}{2}$ ;  $\frac{1}{2}0\frac{1}{2}$ .      (h)  $\frac{1}{2}\frac{1}{2}u$ ;  $\frac{1}{2}\frac{1}{2}\bar{u}$ .

*Four equivalent positions:*

- (i)  $0\frac{1}{2}u$ ;  $\frac{1}{2}0u$ ;  $0\frac{1}{2}\bar{u}$ ;  $\frac{1}{2}0\bar{u}$ .  
 (j)  $u v 0$ ;  $\bar{v} u 0$ ;  $\bar{u} \bar{v} 0$ ;  $v \bar{u} 0$ .  
 (k)  $u v \frac{1}{2}$ ;  $\bar{v} u \frac{1}{2}$ ;  $\bar{u} \bar{v} \frac{1}{2}$ ;  $v \bar{u} \frac{1}{2}$ .

SPACE-GROUP  $C_{4h}^1$  (continued).

Eight equivalent positions:

- (l)  $xyz$ ;  $\bar{y}xz$ ;  $\bar{x}\bar{y}z$ ;  $y\bar{x}z$ ;  
 $\bar{x}\bar{y}\bar{z}$ ;  $y\bar{x}\bar{z}$ ;  $xy\bar{z}$ ;  $\bar{y}x\bar{z}$ .

SPACE-GROUP  $C_{4h}^2$ .

Two equivalent positions:

- (a)  $000$ ;  $00\frac{1}{2}$ . (d)  $0\frac{1}{2}\frac{1}{2}$ ;  $\frac{1}{2}00$ .  
 (b)  $\frac{1}{2}\frac{1}{2}0$ ;  $\frac{1}{2}\frac{1}{2}\frac{1}{2}$ . (e)  $00\frac{1}{2}$ ;  $00\frac{3}{2}$ .  
 (c)  $0\frac{1}{2}0$ ;  $\frac{1}{2}0\frac{1}{2}$ . (f)  $\frac{1}{2}\frac{1}{2}\frac{1}{2}$ ;  $\frac{1}{2}\frac{1}{2}\frac{3}{2}$ .

Four equivalent positions:

- (g)  $00u$ ;  $00\bar{u}$ ;  $0, 0, u+\frac{1}{2}$ ;  $0, 0, \frac{1}{2}-u$ .  
 (h)  $\frac{1}{2}\frac{1}{2}u$ ;  $\frac{1}{2}\frac{1}{2}\bar{u}$ ;  $\frac{1}{2}, \frac{1}{2}, u+\frac{1}{2}$ ;  $\frac{1}{2}, \frac{1}{2}, \frac{1}{2}-u$ .  
 (i)  $0\frac{1}{2}u$ ;  $0\frac{1}{2}\bar{u}$ ;  $\frac{1}{2}, 0, u+\frac{1}{2}$ ;  $\frac{1}{2}, 0, \frac{1}{2}-u$ .  
 (j)  $u v 0$ ;  $\bar{u} \bar{v} 0$ ;  $\bar{v} u \frac{1}{2}$ ;  $v \bar{u} \frac{1}{2}$ .

Eight equivalent positions:

- (k)  $xyz$ ;  $\bar{y}, x, z+\frac{1}{2}$ ;  $\bar{x}\bar{y}z$ ;  $y, \bar{x}, z+\frac{1}{2}$ ;  
 $\bar{x}\bar{y}\bar{z}$ ;  $y, \bar{x}, \frac{1}{2}-z$ ;  $xy\bar{z}$ ;  $\bar{y}, x, \frac{1}{2}-z$ .

SPACE-GROUP  $C_{4h}^3$ .

Two equivalent positions:

- (a)  $0\frac{1}{2}0$ ;  $\frac{1}{2}00$ . (b)  $0\frac{1}{2}\frac{1}{2}$ ;  $\frac{1}{2}0\frac{1}{2}$ . (c)  $00u$ ;  $\frac{1}{2}\frac{1}{2}\bar{u}$ .

Four equivalent positions:

- (d)  $\frac{1}{2}\frac{1}{2}0$ ;  $\frac{3}{2}\frac{1}{2}0$ ;  $\frac{1}{2}\frac{3}{2}0$ ;  $\frac{3}{2}\frac{3}{2}0$ .  
 (e)  $\frac{1}{2}\frac{1}{2}\frac{1}{2}$ ;  $\frac{3}{2}\frac{1}{2}\frac{1}{2}$ ;  $\frac{1}{2}\frac{3}{2}\frac{1}{2}$ ;  $\frac{3}{2}\frac{3}{2}\frac{1}{2}$ .  
 (f)  $0\frac{1}{2}u$ ;  $\frac{1}{2}0u$ ;  $\frac{1}{2}0\bar{u}$ ;  $0\frac{1}{2}\bar{u}$ .

Eight equivalent positions:

- (g)  $xyz$ ;  $\bar{y}xz$ ;  $\bar{x}\bar{y}z$ ;  $y\bar{x}z$ ;  
 $\frac{1}{2}-x, \frac{1}{2}-y, \bar{z}$ ;  $y+\frac{1}{2}, \frac{1}{2}-x, \bar{z}$ ;  $x+\frac{1}{2}, y+\frac{1}{2}, \bar{z}$ ;  $\frac{1}{2}-y, x+\frac{1}{2}, \bar{z}$ .

SPACE-GROUP  $C_{4h}^4$ .

Two equivalent positions:

- (a)  $0\frac{1}{2}\frac{1}{2}$ ;  $\frac{1}{2}0\frac{3}{2}$ . (b)  $0\frac{1}{2}\frac{3}{2}$ ;  $\frac{1}{2}0\frac{1}{2}$ .

Four equivalent positions:

- (c)  $\frac{1}{2}\frac{1}{2}0$ ;  $\frac{3}{2}\frac{1}{2}\frac{1}{2}$ ;  $\frac{3}{2}\frac{3}{2}0$ ;  $\frac{1}{2}\frac{3}{2}\frac{1}{2}$ .  
 (d)  $\frac{1}{2}\frac{1}{2}\frac{1}{2}$ ;  $\frac{3}{2}\frac{1}{2}0$ ;  $\frac{3}{2}\frac{3}{2}\frac{1}{2}$ ;  $\frac{1}{2}\frac{3}{2}0$ .  
 (e)  $00u$ ;  $\frac{1}{2}\frac{1}{2}\bar{u}$ ;  $\frac{1}{2}, \frac{1}{2}, \frac{1}{2}-u$ ;  $0, 0, u+\frac{1}{2}$ .  
 (f)  $0\frac{1}{2}u$ ;  $\frac{1}{2}0\bar{u}$ ;  $\frac{1}{2}, 0, u+\frac{1}{2}$ ;  $0, \frac{1}{2}, \frac{1}{2}-u$ .

Eight equivalent positions:

- (g)  $xyz$ ;  $\bar{y}, x, z+\frac{1}{2}$ ;  $\bar{x}\bar{y}z$ ;  $y, \bar{x}, z+\frac{1}{2}$ ;  
 $\frac{1}{2}-x, \frac{1}{2}-y, \bar{z}$ ;  $y+\frac{1}{2}, \frac{1}{2}-x, \frac{1}{2}-z$ ;  $x+\frac{1}{2}, y+\frac{1}{2}, \bar{z}$ ;  
 $\frac{1}{2}-y, x+\frac{1}{2}, \frac{1}{2}-z$ .

SPACE-GROUP  $C_{2h}^5$ *Two equivalent positions:*

(a)  $000$ ;  $\frac{1}{2}\frac{1}{2}\frac{1}{2}$ . (b)  $00\frac{1}{2}$ ;  $\frac{1}{2}\frac{1}{2}0$ .

*Four equivalent positions:*

(c)  $0\frac{1}{2}0$ ;  $\frac{1}{2}00$ ;  $\frac{1}{2}0\frac{1}{2}$ ;  $0\frac{1}{2}\frac{1}{2}$ .  
(d)  $0\frac{1}{2}\frac{1}{2}$ ;  $\frac{1}{2}0\frac{1}{2}$ ;  $0\frac{1}{2}\frac{1}{2}$ ;  $\frac{1}{2}0\frac{1}{2}$ .  
(e)  $00u$ ;  $00\bar{u}$ ;  $\frac{1}{2}, \frac{1}{2}, u+\frac{1}{2}$ ;  $\frac{1}{2}, \frac{1}{2}, \frac{1}{2}-u$ .

*Eight equivalent positions:*

(f)  $\frac{1}{2}\frac{1}{2}\frac{1}{2}$ ;  $\frac{1}{2}\frac{1}{2}\frac{1}{2}$ ;  $\frac{1}{2}\frac{1}{2}\frac{1}{2}$ ;  $\frac{1}{2}\frac{1}{2}\frac{1}{2}$ ;  
 $\frac{1}{2}\frac{1}{2}\frac{1}{2}$ ;  $\frac{1}{2}\frac{1}{2}\frac{1}{2}$ ;  $\frac{1}{2}\frac{1}{2}\frac{1}{2}$ ;  $\frac{1}{2}\frac{1}{2}\frac{1}{2}$ .  
(g)  $0\frac{1}{2}u$ ;  $\frac{1}{2}0u$ ;  $\frac{1}{2}, 0, u+\frac{1}{2}$ ;  $0, \frac{1}{2}, u+\frac{1}{2}$ ;  
 $0\frac{1}{2}\bar{u}$ ;  $\frac{1}{2}0\bar{u}$ ;  $\frac{1}{2}, 0, \frac{1}{2}-u$ ;  $0, \frac{1}{2}, \frac{1}{2}-u$ .  
(h)  $uv0$ ;  $\bar{v}u0$ ;  $\frac{1}{2}-v, u+\frac{1}{2}, \frac{1}{2}$ ;  $u+\frac{1}{2}, v+\frac{1}{2}, \frac{1}{2}$ ;  
 $u\bar{v}0$ ;  $v\bar{u}0$ ;  $v+\frac{1}{2}, \frac{1}{2}-u, \frac{1}{2}$ ;  $\frac{1}{2}-u, \frac{1}{2}-v, \frac{1}{2}$ .

*Sixteen equivalent positions:*

(i)  $xyz$ ;  $\bar{y}xz$ ;  $x\bar{y}z$ ;  $y\bar{x}z$ ;  
 $x\bar{y}\bar{z}$ ;  $y\bar{x}\bar{z}$ ;  $xy\bar{z}$ ;  $\bar{y}x\bar{z}$ ;  
 $x+\frac{1}{2}, y+\frac{1}{2}, z+\frac{1}{2}$ ;  $\frac{1}{2}-y, x+\frac{1}{2}, z+\frac{1}{2}$ ;  $\frac{1}{2}-x, \frac{1}{2}-y, z+\frac{1}{2}$ ;  
 $y+\frac{1}{2}, \frac{1}{2}-x, z+\frac{1}{2}$ ;  
 $\frac{1}{2}-x, \frac{1}{2}-y, \frac{1}{2}-z$ ;  $y+\frac{1}{2}, \frac{1}{2}-x, \frac{1}{2}-z$ ;  $x+\frac{1}{2}, y+\frac{1}{2}, \frac{1}{2}-z$ ;  
 $\frac{1}{2}-y, x+\frac{1}{2}, \frac{1}{2}-z$ .

SPACE-GROUP  $C_{2h}^6$ \**Four equivalent positions:*

(a)  $0\frac{1}{2}\frac{1}{2}$ ;  $0\frac{1}{2}\frac{1}{2}$ ;  $\frac{1}{2}\frac{1}{2}\frac{1}{2}$ ;  $\frac{1}{2}\frac{1}{2}\frac{1}{2}$ .  
(b)  $0\frac{1}{2}\frac{1}{2}$ ;  $0\frac{1}{2}\frac{1}{2}$ ;  $\frac{1}{2}\frac{1}{2}\frac{1}{2}$ ;  $\frac{1}{2}\frac{1}{2}\frac{1}{2}$ .

*Eight equivalent positions:*

(c)  $000$ ;  $\frac{1}{2}\frac{1}{2}\frac{1}{2}$ ;  $\frac{1}{2}0\frac{1}{2}$ ;  $\frac{1}{2}\frac{1}{2}\frac{1}{2}$ ;  
 $0\frac{1}{2}0$ ;  $\frac{1}{2}\frac{1}{2}\frac{1}{2}$ ;  $\frac{1}{2}\frac{1}{2}\frac{1}{2}$ ;  $\frac{1}{2}\frac{1}{2}\frac{1}{2}$ .  
(d)  $00\frac{1}{2}$ ;  $\frac{1}{2}\frac{1}{2}\frac{1}{2}$ ;  $\frac{1}{2}00$ ;  $\frac{1}{2}\frac{1}{2}\frac{1}{2}$ ;  
 $0\frac{1}{2}\frac{1}{2}$ ;  $\frac{1}{2}\frac{1}{2}\frac{1}{2}$ ;  $\frac{1}{2}\frac{1}{2}0$ ;  $\frac{1}{2}\frac{1}{2}\frac{1}{2}$ .  
(e)  $0\frac{1}{2}u$ ;  $\frac{1}{2}, \frac{1}{2}, u+\frac{1}{2}$ ;  $\frac{1}{2}, \frac{1}{2}, u+\frac{1}{2}$ ;  $0, \frac{1}{2}, u+\frac{1}{2}$ ;  
 $0\frac{1}{2}\bar{u}$ ;  $\frac{1}{2}, \frac{1}{2}, \frac{1}{2}-u$ ;  $\frac{1}{2}, \frac{1}{2}, \frac{1}{2}-u$ ;  $0, \frac{1}{2}, \frac{1}{2}-u$ .

*Sixteen equivalent positions:*

(f)  $xyz$ ;  $y+\frac{1}{2}, \frac{1}{2}-x, z+\frac{1}{2}$ ;  $\frac{1}{2}-x, y, z+\frac{1}{2}$ ;  $\frac{1}{2}-y, x+\frac{1}{2}, z+\frac{1}{2}$ ;  
 $x, y+\frac{1}{2}, z$ ;  $y+\frac{1}{2}, \frac{1}{2}-x, \frac{1}{2}-z$ ;  $\frac{1}{2}-x, \frac{1}{2}-y, \frac{1}{2}-z$ ;  
 $\frac{1}{2}-y, x+\frac{1}{2}, \frac{1}{2}-z$ ;  
 $x+\frac{1}{2}, y+\frac{1}{2}, z+\frac{1}{2}$ ;  $y+\frac{1}{2}, \frac{1}{2}-x, z+\frac{1}{2}$ ;  $x, \frac{1}{2}-y, z$ ;  
 $\frac{1}{2}-y, x+\frac{1}{2}, z+\frac{1}{2}$ ;  
 $x+\frac{1}{2}, y, \frac{1}{2}-z$ ;  $y+\frac{1}{2}, \frac{1}{2}-x, \frac{1}{2}-z$ ;  $x\bar{y}\bar{z}$ ;  $\frac{1}{2}-y, x+\frac{1}{2}, \frac{1}{2}-z$ .

## E. HEMIMORPHIC HEMIHEDRY.

SPACE-GROUP  $C_{4v}^1$ .*One equivalent position:*

(a)  $00u$ .      (b)  $\frac{1}{2}\frac{1}{2}u$ .

*Two equivalent positions:*

(c)  $0\frac{1}{2}u$ ;  $\frac{1}{2}0u$ .

*Four equivalent positions:*

(d)  $uu v$ ;  $\bar{u}u v$ ;  $\bar{u}\bar{u} v$ ;  $u\bar{u} v$ .

(e)  $u0 v$ ;  $0u v$ ;  $\bar{u}0 v$ ;  $0\bar{u} v$ .

(f)  $u\frac{1}{2}v$ ;  $\frac{1}{2}u v$ ;  $\bar{u}\frac{1}{2}v$ ;  $\frac{1}{2}\bar{u} v$ .

*Eight equivalent positions:*

(g)  $xyz$ ;  $\bar{y}xz$ ;  $\bar{x}\bar{y}z$ ;  $y\bar{x}z$ ;

$yxz$ ;  $x\bar{y}z$ ;  $\bar{y}\bar{x}z$ ;  $\bar{x}yz$ .

SPACE-GROUP  $C_{4v}^2$ .*Two equivalent positions:*

(a)  $00u$ ;  $\frac{1}{2}\frac{1}{2}u$ .      (b)  $0\frac{1}{2}u$ ;  $\frac{1}{2}0u$ .

*Four equivalent positions:*

(c)  $u, \frac{1}{2}-u, v$ ;  $u+\frac{1}{2}, u, v$ ;  $\bar{u}, u+\frac{1}{2}, v$ ;  $\frac{1}{2}-u, \bar{u}, v$ .

*Eight equivalent positions:*

(d)  $xyz$ ;       $\bar{y}xz$ ;       $\bar{x}\bar{y}z$ ;       $y\bar{x}z$ ;  
 $y+\frac{1}{2}, x+\frac{1}{2}, z$ ;  $x+\frac{1}{2}, \frac{1}{2}-y, z$ ;  $\frac{1}{2}-y, \frac{1}{2}-x, z$ ;  $\frac{1}{2}-x, y+\frac{1}{2}, z$ .

SPACE-GROUP  $C_{4v}^3$ .*Two equivalent positions:*

(a)  $00u$ ;  $0, 0, u+\frac{1}{2}$ .      (b)  $\frac{1}{2}\frac{1}{2}u$ ;  $\frac{1}{2}, \frac{1}{2}, u+\frac{1}{2}$ .

*Four equivalent positions:*

(c)  $0\frac{1}{2}u$ ;  $\frac{1}{2}0u$ ;  $\frac{1}{2}, 0, u+\frac{1}{2}$ ;  $0, \frac{1}{2}, u+\frac{1}{2}$ .

(d)  $uu v$ ;  $\bar{u}\bar{u} v$ ;  $\bar{u}, u, v+\frac{1}{2}$ ;  $u, \bar{u}, v+\frac{1}{2}$ .

*Eight equivalent positions:*

(e)  $xyz$ ;  $\bar{y}, x, z+\frac{1}{2}$ ;  $\bar{x}\bar{y}z$ ;  $y, \bar{x}, z+\frac{1}{2}$ ;

$yxz$ ;  $x, \bar{y}, z+\frac{1}{2}$ ;  $\bar{y}\bar{x}z$ ;  $\bar{x}, y, z+\frac{1}{2}$ .

SPACE-GROUP  $C_{4v}^4$ .\**Two equivalent positions:*

(a)  $00u$ ;  $\frac{1}{2}, \frac{1}{2}, u+\frac{1}{2}$ .

*Four equivalent positions:*

(b)  $0\frac{1}{2}u$ ;  $0, \frac{1}{2}, u+\frac{1}{2}$ ;       $\frac{1}{2}0u$ ;  $\frac{1}{2}, 0, u+\frac{1}{2}$ .

(c)  $uu v$ ;  $u+\frac{1}{2}, \frac{1}{2}-u, v+\frac{1}{2}$ ;  $\bar{u}\bar{u} v$ ;  $\frac{1}{2}-u, u+\frac{1}{2}, v+\frac{1}{2}$ .



SPACE-GROUP  $C_{4v}^4$  (continued).*Eight equivalent positions:*

$$(d) \begin{array}{l} xyz; \quad y+\frac{1}{2}, \frac{1}{2}-x, z+\frac{1}{2}; \quad \bar{x}\bar{y}z; \quad \frac{1}{2}-y, x+\frac{1}{2}, z+\frac{1}{2}; \\ \frac{1}{2}-x, y+\frac{1}{2}, z+\frac{1}{2}; \quad \bar{y}\bar{x}z; \quad x+\frac{1}{2}, \frac{1}{2}-y, z+\frac{1}{2}; \quad yxz. \end{array}$$

SPACE-GROUP  $C_{4v}^5$ .*Two equivalent positions:*

$$(a) 00u; \quad 0, 0, u+\frac{1}{2}. \quad (b) \frac{1}{2}\frac{1}{2}u; \quad \frac{1}{2}, \frac{1}{2}, u+\frac{1}{2}.$$

*Four equivalent positions:*

$$(c) 0\frac{1}{2}u; \quad \frac{1}{2}0u; \quad \frac{1}{2}, 0, u+\frac{1}{2}; \quad 0, \frac{1}{2}, u+\frac{1}{2}.$$

*Eight equivalent positions:*

$$(d) \begin{array}{llll} xyz; & \bar{y}xz; & \bar{x}\bar{y}z; & y\bar{x}z; \\ y, x, z+\frac{1}{2}; & x, \bar{y}, z+\frac{1}{2}; & \bar{y}, \bar{x}, z+\frac{1}{2}; & \bar{x}, y, z+\frac{1}{2}. \end{array}$$

SPACE-GROUP  $C_{4v}^6$ .*Two equivalent positions:*

$$(a) 00u; \quad \frac{1}{2}, \frac{1}{2}, u+\frac{1}{2}.$$

*Four equivalent positions:*

$$(b) 0\frac{1}{2}u; \quad \frac{1}{2}0u; \quad \frac{1}{2}, 0, u+\frac{1}{2}; \quad 0, \frac{1}{2}, u+\frac{1}{2}.$$

*Eight equivalent positions:*

$$(c) \begin{array}{llll} xyz; & \bar{y}xz; & \bar{x}\bar{y}z; & y\bar{x}z; \\ y+\frac{1}{2}, x+\frac{1}{2}, z+\frac{1}{2}; & x+\frac{1}{2}, \frac{1}{2}-y, z+\frac{1}{2}; & \frac{1}{2}-y, \frac{1}{2}-x, z+\frac{1}{2}; & \frac{1}{2}-x, y+\frac{1}{2}, z+\frac{1}{2}. \end{array}$$

SPACE-GROUP  $C_{4v}^7$ .*Two equivalent positions:*

$$(a) 00u; \quad 0, 0, u+\frac{1}{2}. \quad (b) \frac{1}{2}\frac{1}{2}u; \quad \frac{1}{2}, \frac{1}{2}, u+\frac{1}{2}.$$

$$(c) 0\frac{1}{2}u; \quad \frac{1}{2}, 0, u+\frac{1}{2}.$$

*Four equivalent positions:*

$$(d) u0v; \quad \bar{u}0v; \quad 0, \bar{u}, v+\frac{1}{2}; \quad 0, u, v+\frac{1}{2}.$$

$$(e) u\frac{1}{2}v; \quad \bar{u}\frac{1}{2}v; \quad \frac{1}{2}, \bar{u}, v+\frac{1}{2}; \quad \frac{1}{2}, u, v+\frac{1}{2}.$$

*Eight equivalent positions:*

$$(f) \begin{array}{llll} xyz; & \bar{y}, x, z+\frac{1}{2}; & \bar{x}\bar{y}z; & y, \bar{x}, z+\frac{1}{2}; \\ y, x, z+\frac{1}{2}; & x\bar{y}z; & \bar{y}, \bar{x}, z+\frac{1}{2}; & \bar{x}yz. \end{array}$$

SPACE-GROUP  $C_{4v}^8$ .*Four equivalent positions:*

$$(a) 00u; \quad \frac{1}{2}\frac{1}{2}u; \quad \frac{1}{2}, \frac{1}{2}, u+\frac{1}{2}; \quad 0, 0, u+\frac{1}{2}.$$

$$(b) 0\frac{1}{2}u; \quad \frac{1}{2}0u; \quad \frac{1}{2}, 0, u+\frac{1}{2}; \quad 0, \frac{1}{2}, u+\frac{1}{2}.$$

*Eight equivalent positions:*

$$(c) \begin{array}{llll} xyz; & \bar{y}, x, z+\frac{1}{2}; & \bar{x}\bar{y}z; & y, \bar{x}, z+\frac{1}{2}; \\ y+\frac{1}{2}, x+\frac{1}{2}, z+\frac{1}{2}; & x+\frac{1}{2}, \frac{1}{2}-y, z; & \frac{1}{2}-y, \frac{1}{2}-x, z+\frac{1}{2}; & \frac{1}{2}-x, y+\frac{1}{2}, z. \end{array}$$

SPACE-GROUP  $C_{4v}^9$ .

Two equivalent positions:

(a)  $00u$ ;  $\frac{1}{2}, \frac{1}{2}, u+\frac{1}{2}$ .

Four equivalent positions:

(b)  $0\frac{1}{2}u$ ;  $\frac{1}{2}0u$ ;  $\frac{1}{2}, 0, u+\frac{1}{2}$ ;  $0, \frac{1}{2}, u+\frac{1}{2}$ .

Eight equivalent positions:

(c)  $uu v$ ;  $u\bar{u}v$ ;  $u+\frac{1}{2}, \frac{1}{2}-u, v+\frac{1}{2}$ ;  $u+\frac{1}{2}, u+\frac{1}{2}, v+\frac{1}{2}$ ;  
 $\bar{u}\bar{u}v$ ;  $\bar{u}uv$ ;  $\frac{1}{2}-u, u+\frac{1}{2}, v+\frac{1}{2}$ ;  $\frac{1}{2}-u, \frac{1}{2}-u, v+\frac{1}{2}$ .  
 (d)  $u0v$ ;  $0uv$ ;  $\frac{1}{2}, u+\frac{1}{2}, v+\frac{1}{2}$ ;  $u+\frac{1}{2}, \frac{1}{2}, v+\frac{1}{2}$ ;  
 $\bar{u}0v$ ;  $0\bar{u}v$ ;  $\frac{1}{2}, \frac{1}{2}-u, v+\frac{1}{2}$ ;  $\frac{1}{2}-u, \frac{1}{2}, v+\frac{1}{2}$ .

Sixteen equivalent positions:

(e)  $xyz$ ;  $\bar{y}xz$ ;  $\bar{x}\bar{y}z$ ;  $y\bar{x}z$ ;  
 $yxz$ ;  $x\bar{y}z$ ;  $\bar{y}\bar{x}z$ ;  $\bar{x}yz$ ;  
 $x+\frac{1}{2}, y+\frac{1}{2}, z+\frac{1}{2}$ ;  $\frac{1}{2}-y, x+\frac{1}{2}, z+\frac{1}{2}$ ;  $\frac{1}{2}-x, \frac{1}{2}-y, z+\frac{1}{2}$ ;  
 $y+\frac{1}{2}, \frac{1}{2}-x, z+\frac{1}{2}$ ;  
 $y+\frac{1}{2}, x+\frac{1}{2}, z+\frac{1}{2}$ ;  $x+\frac{1}{2}, \frac{1}{2}-y, z+\frac{1}{2}$ ;  $\frac{1}{2}-y, \frac{1}{2}-x, z+\frac{1}{2}$ ;  
 $\frac{1}{2}-x, y+\frac{1}{2}, z+\frac{1}{2}$ .

SPACE-GROUP  $C_{4v}^{10}$ .

Four equivalent positions:

(a)  $00u$ ;  $\frac{1}{2}\frac{1}{2}u$ ;  $\frac{1}{2}, \frac{1}{2}, u+\frac{1}{2}$ ;  $0, 0, u+\frac{1}{2}$ .  
 (b)  $0\frac{1}{2}u$ ;  $\frac{1}{2}0u$ ;  $\frac{1}{2}, 0, u+\frac{1}{2}$ ;  $0, \frac{1}{2}, u+\frac{1}{2}$ .

Eight equivalent positions:

(c)  $u, u+\frac{1}{2}, v$ ;  $\frac{1}{2}-u, u, v$ ;  $\bar{u}, u+\frac{1}{2}, v+\frac{1}{2}$ ;  $u+\frac{1}{2}, u, v+\frac{1}{2}$ ;  
 $\bar{u}, \frac{1}{2}-u, v$ ;  $u+\frac{1}{2}, \bar{u}, v$ ;  $u, \frac{1}{2}-u, v+\frac{1}{2}$ ;  $\frac{1}{2}-u, \bar{u}, v+\frac{1}{2}$ .

Sixteen equivalent positions:

(d)  $xyz$ ;  $\bar{y}xz$ ;  $\bar{x}\bar{y}z$ ;  $y\bar{x}z$ ;  
 $y, x, z+\frac{1}{2}$ ;  $x, \bar{y}, z+\frac{1}{2}$ ;  $\bar{y}, \bar{x}, z+\frac{1}{2}$ ;  $\bar{x}, y, z+\frac{1}{2}$ ;  
 $x+\frac{1}{2}, y+\frac{1}{2}, z+\frac{1}{2}$ ;  $\frac{1}{2}-y, x+\frac{1}{2}, z+\frac{1}{2}$ ;  $\frac{1}{2}-x, \frac{1}{2}-y, z+\frac{1}{2}$ ;  
 $y+\frac{1}{2}, \frac{1}{2}-x, z+\frac{1}{2}$ ;  
 $y+\frac{1}{2}, x+\frac{1}{2}, z$ ;  $x+\frac{1}{2}, \frac{1}{2}-y, z$ ;  $\frac{1}{2}-y, \frac{1}{2}-x, z$ ;  $\frac{1}{2}-x, y+\frac{1}{2}, z$ .

SPACE-GROUP  $C_{4v}^{11}$ .\*

Four equivalent positions:

(a)  $00u$ ;  $0, \frac{1}{2}, u+\frac{1}{2}$ ;  $\frac{1}{2}, 0, u+\frac{1}{2}$ ;  $\frac{1}{2}, \frac{1}{2}, u+\frac{1}{2}$ .

Eight equivalent positions:

(b)  $0uv$ ;  $u, \frac{1}{2}, v+\frac{1}{2}$ ;  $\frac{1}{2}, u+\frac{1}{2}, v+\frac{1}{2}$ ;  $\frac{1}{2}-u, 0, v+\frac{1}{2}$ ;  
 $0\bar{u}v$ ;  $\bar{u}, \frac{1}{2}, v+\frac{1}{2}$ ;  $\frac{1}{2}, \frac{1}{2}-u, v+\frac{1}{2}$ ;  $u+\frac{1}{2}, 0, v+\frac{1}{2}$ .

SPACE-GROUP  $C_{4v}^{11}$  (continued).*Sixteen* equivalent positions:

$$\begin{aligned}
 (c) \quad & xyz; \quad y, \frac{1}{2}-x, z+\frac{1}{2}; \quad \bar{x}\bar{y}z; \quad \frac{1}{2}-y, x, z+\frac{1}{2}; \\
 & \bar{x}yz; \quad \bar{y}, \frac{1}{2}-x, z+\frac{1}{2}; \quad x\bar{y}z; \quad y+\frac{1}{2}, x, z+\frac{1}{2}; \\
 & x+\frac{1}{2}, y+\frac{1}{2}, z+\frac{1}{2}; \quad y+\frac{1}{2}, \bar{x}, z+\frac{1}{2}; \quad \frac{1}{2}-x, \frac{1}{2}-y, z+\frac{1}{2}; \\
 & \frac{1}{2}-x, y+\frac{1}{2}, z+\frac{1}{2}; \quad \frac{1}{2}-y, \bar{x}, z+\frac{1}{2}; \quad x+\frac{1}{2}, \frac{1}{2}-y, z+\frac{1}{2}; \\
 & \bar{y}, x+\frac{1}{2}, z+\frac{1}{2}; \\
 & y, x+\frac{1}{2}, z+\frac{1}{2}.
 \end{aligned}$$

SPACE-GROUP  $C_{4v}^{12}$ .\**Eight* equivalent positions:

$$\begin{aligned}
 (a) \quad & 00u; \quad 0, \frac{1}{2}, u+\frac{1}{2}; \quad \frac{1}{2}, 0, u+\frac{1}{2}; \quad 0, 0, u+\frac{1}{2}; \\
 & \frac{1}{2}\frac{1}{2}u; \quad \frac{1}{2}, 0, u+\frac{1}{2}; \quad 0, \frac{1}{2}, u+\frac{1}{2}; \quad \frac{1}{2}, \frac{1}{2}, u+\frac{1}{2}.
 \end{aligned}$$

*Sixteen* equivalent positions:

$$\begin{aligned}
 (b) \quad & xyz; \quad y, \frac{1}{2}-x, z+\frac{1}{2}; \quad \bar{x}\bar{y}z; \quad \frac{1}{2}-y, x, z+\frac{1}{2}; \\
 & \bar{x}, y, z+\frac{1}{2}; \quad \bar{y}, \frac{1}{2}-x, z+\frac{1}{2}; \quad x, \bar{y}, z+\frac{1}{2}; \quad y+\frac{1}{2}, x, z+\frac{1}{2}; \\
 & x+\frac{1}{2}, y+\frac{1}{2}, z+\frac{1}{2}; \quad y+\frac{1}{2}, \bar{x}, z+\frac{1}{2}; \quad \frac{1}{2}-x, \frac{1}{2}-y, z+\frac{1}{2}; \\
 & \frac{1}{2}-x, y+\frac{1}{2}, z; \quad \frac{1}{2}-y, \bar{x}, z+\frac{1}{2}; \quad x+\frac{1}{2}, \frac{1}{2}-y, z; \quad y, x+\frac{1}{2}, z+\frac{1}{2}. \\
 & \bar{y}, x+\frac{1}{2}, z+\frac{1}{2};
 \end{aligned}$$

## F. ENANTIOMORPHIC HEMIHEDRY.

SPACE-GROUP  $D_4^1$ .*One* equivalent position:

$$\begin{aligned}
 (a) \quad & 000. & (c) \quad & \frac{1}{2}\frac{1}{2}0. \\
 (b) \quad & 00\frac{1}{2}. & (d) \quad & \frac{1}{2}\frac{1}{2}\frac{1}{2}.
 \end{aligned}$$

*Two* equivalent positions:

$$\begin{aligned}
 (e) \quad & 0\frac{1}{2}0; \quad \frac{1}{2}00. & (g) \quad & 00u; \quad 00\bar{u}. \\
 (f) \quad & 0\frac{1}{2}\frac{1}{2}; \quad \frac{1}{2}0\frac{1}{2}. & (h) \quad & \frac{1}{2}\frac{1}{2}u; \quad \frac{1}{2}\frac{1}{2}\bar{u}.
 \end{aligned}$$

*Four* equivalent positions:

$$\begin{aligned}
 (i) \quad & 0\frac{1}{2}u; \quad \frac{1}{2}0u; \quad 0\frac{1}{2}\bar{u}; \quad \frac{1}{2}0\bar{u}. \\
 (j) \quad & uu0; \quad \bar{u}u0; \quad \bar{u}\bar{u}0; \quad u\bar{u}0. \\
 (k) \quad & uu\frac{1}{2}; \quad \bar{u}u\frac{1}{2}; \quad \bar{u}\bar{u}\frac{1}{2}; \quad u\bar{u}\frac{1}{2}. \\
 (l) \quad & u00; \quad 0u0; \quad \bar{u}00; \quad 0\bar{u}0. \\
 (m) \quad & u\frac{1}{2}\frac{1}{2}; \quad \frac{1}{2}u\frac{1}{2}; \quad \bar{u}\frac{1}{2}\frac{1}{2}; \quad \frac{1}{2}\bar{u}\frac{1}{2}. \\
 (n) \quad & u0\frac{1}{2}; \quad 0u\frac{1}{2}; \quad \bar{u}0\frac{1}{2}; \quad 0\bar{u}\frac{1}{2}. \\
 (o) \quad & u\frac{1}{2}0; \quad \frac{1}{2}u0; \quad \bar{u}\frac{1}{2}0; \quad \frac{1}{2}\bar{u}0.
 \end{aligned}$$

*Eight* equivalent positions:

$$\begin{aligned}
 (p) \quad & xyz; \quad \bar{y}xz; \quad \bar{x}\bar{y}z; \quad y\bar{x}z; \\
 & yx\bar{z}; \quad x\bar{y}\bar{z}; \quad \bar{y}\bar{x}\bar{z}; \quad \bar{x}y\bar{z}.
 \end{aligned}$$

SPACE-GROUP  $D_4^2$ .\**Two* equivalent positions:

$$\begin{aligned}
 (a) \quad & 000; \quad \frac{1}{2}\frac{1}{2}0. & (c) \quad & 0\frac{1}{2}u; \quad \frac{1}{2}0\bar{u}. \\
 (b) \quad & 00\frac{1}{2}; \quad \frac{1}{2}\frac{1}{2}\frac{1}{2}.
 \end{aligned}$$

SPACE-GROUP  $D_4^2$  (continued).*Four equivalent positions:*

- (d)  $00u$ ;  $00\bar{u}$ ;  $\frac{1}{2}\frac{1}{2}u$ ;  $\frac{1}{2}\frac{1}{2}\bar{u}$ .  
 (e)  $uu0$ ;  $\bar{u}\bar{u}0$ ;  $u+\frac{1}{2}, \frac{1}{2}-u, 0$ ;  $\frac{1}{2}-u, u+\frac{1}{2}, 0$ .  
 (f)  $uu\frac{1}{2}$ ;  $\bar{u}\bar{u}\frac{1}{2}$ ;  $u+\frac{1}{2}, \frac{1}{2}-u, \frac{1}{2}$ ;  $\frac{1}{2}-u, u+\frac{1}{2}, \frac{1}{2}$ .

*Eight equivalent positions:*

- (g)  $xyz$ ;  $y+\frac{1}{2}, \frac{1}{2}-x, z$ ;  $\bar{x}\bar{y}z$ ;  $\frac{1}{2}-y, x+\frac{1}{2}, z$ ;  
 $\frac{1}{2}-x, y+\frac{1}{2}, \bar{z}$ ;  $\bar{y}\bar{x}\bar{z}$ ;  $x+\frac{1}{2}, \frac{1}{2}-y, \bar{z}$ ;  $yx\bar{z}$ .

SPACE-GROUP  $D_4^3$ .\**Four equivalent positions:*

- (a)  $0u0$ ;  $u0\frac{1}{2}$ ;  $0\bar{u}\frac{1}{2}$ ;  $\bar{u}0\frac{1}{2}$ .  
 (b)  $\frac{1}{2}u\frac{1}{2}$ ;  $u\frac{1}{2}\frac{1}{2}$ ;  $\frac{1}{2}\bar{u}0$ ;  $\bar{u}\frac{1}{2}\frac{1}{2}$ .  
 (c)  $uu\frac{1}{2}$ ;  $u\bar{u}\frac{1}{2}$ ;  $\bar{u}\bar{u}\frac{1}{2}$ ;  $\bar{u}u\frac{1}{2}$ .

*Eight equivalent positions:*

- (d)  $xyz$ ;  $y, \bar{x}, z+\frac{1}{2}$ ;  $\bar{x}, \bar{y}, z+\frac{1}{2}$ ;  $\bar{y}, x, z+\frac{1}{2}$ ;  
 $\bar{x}\bar{y}\bar{z}$ ;  $\bar{y}, \bar{x}, \frac{1}{2}-z$ ;  $x, \bar{y}, \frac{1}{2}-z$ ;  $y, x, \frac{1}{2}-z$ .

SPACE-GROUP  $D_4^4$ .\**Four equivalent positions:*

- (a)  $uu0$ ;  $\bar{u}\bar{u}\frac{1}{2}$ ;  $u+\frac{1}{2}, \frac{1}{2}-u, \frac{1}{2}$ ;  $\frac{1}{2}-u, u+\frac{1}{2}, \frac{1}{2}$ .

*Eight equivalent positions:*

- (b)  $xyz$ ;  $y+\frac{1}{2}, \frac{1}{2}-x, z+\frac{1}{2}$ ;  $\bar{x}, \bar{y}, z+\frac{1}{2}$ ;  $\frac{1}{2}-y, x+\frac{1}{2}, z+\frac{1}{2}$ ;  
 $\frac{1}{2}-x, y+\frac{1}{2}, \frac{1}{2}-z$ ;  $\bar{y}, \bar{x}, \frac{1}{2}-z$ ;  $x+\frac{1}{2}, \frac{1}{2}-y, \frac{1}{2}-z$ ;  $yx\bar{z}$ .

SPACE-GROUP  $D_4^5$ .\**Two equivalent positions:*

- (a)  $000$ ;  $00\frac{1}{2}$ . (d)  $0\frac{1}{2}\frac{1}{2}$ ;  $\frac{1}{2}00$ .  
 (b)  $\frac{1}{2}\frac{1}{2}0$ ;  $\frac{1}{2}\frac{1}{2}\frac{1}{2}$ . (e)  $00\frac{1}{2}$ ;  $00\frac{1}{2}$ .  
 (c)  $0\frac{1}{2}0$ ;  $\frac{1}{2}0\frac{1}{2}$ . (f)  $\frac{1}{2}\frac{1}{2}\frac{1}{2}$ ;  $\frac{1}{2}\frac{1}{2}\frac{1}{2}$ .

*Four equivalent positions:*

- (g)  $00u$ ;  $00\bar{u}$ ;  $0, 0, u+\frac{1}{2}$ ;  $0, 0, \frac{1}{2}-u$ .  
 (h)  $\frac{1}{2}\frac{1}{2}u$ ;  $\frac{1}{2}\frac{1}{2}\bar{u}$ ;  $\frac{1}{2}, \frac{1}{2}, u+\frac{1}{2}$ ;  $\frac{1}{2}, \frac{1}{2}, \frac{1}{2}-u$ .  
 (i)  $0\frac{1}{2}u$ ;  $0\frac{1}{2}\bar{u}$ ;  $\frac{1}{2}, 0, u+\frac{1}{2}$ ;  $\frac{1}{2}, 0, \frac{1}{2}-u$ .  
 (j)  $u00$ ;  $\bar{u}00$ ;  $0\bar{u}\frac{1}{2}$ ;  $0u\frac{1}{2}$ .  
 (k)  $\bar{u}\frac{1}{2}\frac{1}{2}$ ;  $\bar{u}\frac{1}{2}\frac{1}{2}$ ;  $\frac{1}{2}\bar{u}0$ ;  $\frac{1}{2}u0$ .  
 (l)  $u0\frac{1}{2}$ ;  $\bar{u}0\frac{1}{2}$ ;  $0\bar{u}0$ ;  $0u0$ .  
 (m)  $u\frac{1}{2}0$ ;  $\bar{u}\frac{1}{2}0$ ;  $\frac{1}{2}\bar{u}\frac{1}{2}$ ;  $\frac{1}{2}u\frac{1}{2}$ .  
 (n)  $uu\frac{1}{2}$ ;  $u\bar{u}\frac{1}{2}$ ;  $\bar{u}\bar{u}\frac{1}{2}$ ;  $\bar{u}u\frac{1}{2}$ .  
 (o)  $uu\frac{1}{2}$ ;  $u\bar{u}\frac{1}{2}$ ;  $\bar{u}\bar{u}\frac{1}{2}$ ;  $\bar{u}u\frac{1}{2}$ .

*Eight equivalent positions:*

- (p)  $xyz$ ;  $y, \bar{x}, z+\frac{1}{2}$ ;  $\bar{x}\bar{y}z$ ;  $\bar{y}, x, z+\frac{1}{2}$ ;  
 $\bar{x}\bar{y}\bar{z}$ ;  $\bar{y}, \bar{x}, \frac{1}{2}-z$ ;  $x\bar{y}\bar{z}$ ;  $y, x, \frac{1}{2}-z$ .

SPACE-GROUP  $D_4^6$ \**Two equivalent positions:*

(a)  $000$ ;  $\frac{1}{2}\frac{1}{2}\frac{1}{2}$ . (b)  $00\frac{1}{2}$ ;  $\frac{1}{2}\frac{1}{2}0$ .

*Four equivalent positions:*

(c)  $00u$ ;  $00\bar{u}$ ;  $\frac{1}{2}, \frac{1}{2}, \frac{1}{2}-u$ ;  $\frac{1}{2}, \frac{1}{2}, u+\frac{1}{2}$ .  
(d)  $0\frac{1}{2}u$ ;  $\frac{1}{2}0\bar{u}$ ;  $\frac{1}{2}, 0, \frac{1}{2}-u$ ;  $0, \frac{1}{2}, u+\frac{1}{2}$ .  
(e)  $uu0$ ;  $\bar{u}\bar{u}0$ ;  $u+\frac{1}{2}, \frac{1}{2}-u, \frac{1}{2}$ ;  $\frac{1}{2}-u, u+\frac{1}{2}, \frac{1}{2}$ .  
(f)  $uu\frac{1}{2}$ ;  $\bar{u}\bar{u}\frac{1}{2}$ ;  $u+\frac{1}{2}, \frac{1}{2}-u, 0$ ;  $\frac{1}{2}-u, u+\frac{1}{2}, 0$ .

*Eight equivalent positions:*

(g)  $xyz$ ;  $y+\frac{1}{2}, \frac{1}{2}-x, z+\frac{1}{2}$ ;  $\bar{x}\bar{y}\bar{z}$ ;  $\frac{1}{2}-y, x+\frac{1}{2}, z+\frac{1}{2}$ ;  
 $\frac{1}{2}-x, y+\frac{1}{2}, \frac{1}{2}-z$ ;  $\bar{y}\bar{x}\bar{z}$ ;  $x+\frac{1}{2}, \frac{1}{2}-y, \frac{1}{2}-z$ ;  $yx\bar{z}$ .

SPACE-GROUP  $D_4^7$ \**Four equivalent positions:*

(a)  $0u0$ ;  $u0\frac{1}{2}$ ;  $0\bar{u}\frac{1}{2}$ ;  $\bar{u}0\frac{1}{2}$ .  
(b)  $\frac{1}{2}u\frac{1}{2}$ ;  $u\frac{1}{2}\frac{1}{2}$ ;  $\frac{1}{2}\bar{u}0$ ;  $\bar{u}\frac{1}{2}\frac{1}{2}$ .  
(c)  $uu\frac{1}{2}$ ;  $u\bar{u}\frac{1}{2}$ ;  $\bar{u}\bar{u}\frac{1}{2}$ ;  $\bar{u}u\frac{1}{2}$ .

*Eight equivalent positions:*

(d)  $xyz$ ;  $y, \bar{x}, z+\frac{1}{2}$ ;  $\bar{x}, \bar{y}, z+\frac{1}{2}$ ;  $\bar{y}, x, z+\frac{1}{2}$ ;  
 $\bar{x}\bar{y}\bar{z}$ ;  $\bar{y}, \bar{x}, \frac{1}{2}-z$ ;  $x, \bar{y}, \frac{1}{2}-z$ ;  $y, x, \frac{1}{2}-z$ .

SPACE-GROUP  $D_4^8$ \**Four equivalent positions:*

(a)  $uu0$ ;  $\bar{u}\bar{u}\frac{1}{2}$ ;  $u+\frac{1}{2}, \frac{1}{2}-u, \frac{1}{2}$ ;  $\frac{1}{2}-u, u+\frac{1}{2}, \frac{1}{2}$ .

*Eight equivalent positions:*

(b)  $xyz$ ;  $y+\frac{1}{2}, \frac{1}{2}-x, z+\frac{1}{2}$ ;  $\bar{x}, \bar{y}, z+\frac{1}{2}$ ;  $\frac{1}{2}-y, x+\frac{1}{2}, z+\frac{1}{2}$ ;  
 $yx\bar{z}$ ;  $\frac{1}{2}-x, y+\frac{1}{2}, \frac{1}{2}-z$ ;  $\bar{y}, \bar{x}, \frac{1}{2}-z$ ;  $x+\frac{1}{2}, \frac{1}{2}-y, \frac{1}{2}-z$ .

SPACE-GROUP  $D_4^9$ .*Two equivalent positions:*

(a)  $000$ ;  $\frac{1}{2}\frac{1}{2}\frac{1}{2}$ . (b)  $00\frac{1}{2}$ ;  $\frac{1}{2}\frac{1}{2}0$ .

*Four equivalent positions:*

(c)  $0\frac{1}{2}0$ ;  $\frac{1}{2}00$ ;  $\frac{1}{2}0\frac{1}{2}$ ;  $0\frac{1}{2}\frac{1}{2}$ .  
(d)  $0\frac{1}{2}\frac{1}{2}$ ;  $\frac{1}{2}0\frac{1}{2}$ ;  $\frac{1}{2}0\frac{1}{2}$ ;  $0\frac{1}{2}\frac{1}{2}$ .  
(e)  $00u$ ;  $00\bar{u}$ ;  $\frac{1}{2}, \frac{1}{2}, u+\frac{1}{2}$ ;  $\frac{1}{2}, \frac{1}{2}, \frac{1}{2}-u$ .

*Eight equivalent positions:*

(f)  $0\frac{1}{2}u$ ;  $0\frac{1}{2}\bar{u}$ ;  $0, \frac{1}{2}, u+\frac{1}{2}$ ;  $0, \frac{1}{2}, \frac{1}{2}-u$ ;  
 $\frac{1}{2}0u$ ;  $\frac{1}{2}0\bar{u}$ ;  $\frac{1}{2}, 0, u+\frac{1}{2}$ ;  $\frac{1}{2}, 0, \frac{1}{2}-u$ .  
(g)  $uu0$ ;  $\bar{u}\bar{u}0$ ;  $u+\frac{1}{2}, u+\frac{1}{2}, \frac{1}{2}$ ;  $\frac{1}{2}-u, u+\frac{1}{2}, \frac{1}{2}$ ;  
 $\bar{u}\bar{u}0$ ;  $u\bar{u}0$ ;  $\frac{1}{2}-u, \frac{1}{2}-u, \frac{1}{2}$ ;  $u+\frac{1}{2}, \frac{1}{2}-u, \frac{1}{2}$ .

SPACE-GROUP  $D_4^0$  (continued).

- (h)  $u\ 0\ 0$ ;  $0\ u\ 0$ ;  $u+\frac{1}{2}, \frac{1}{2}, \frac{1}{2}$ ;  $\frac{1}{2}, u+\frac{1}{2}, \frac{1}{2}$ ;  
 $\bar{u}\ 0\ 0$ ;  $0\ \bar{u}\ 0$ ;  $\frac{1}{2}-u, \frac{1}{2}, \frac{1}{2}$ ;  $\frac{1}{2}, \frac{1}{2}-u, \frac{1}{2}$ .  
 (i)  $u\ 0\ \frac{1}{2}$ ;  $0\ u\ \frac{1}{2}$ ;  $u+\frac{1}{2}, \frac{1}{2}, 0$ ;  $\frac{1}{2}, u+\frac{1}{2}, 0$ ;  
 $\bar{u}\ 0\ \frac{1}{2}$ ;  $0\ \bar{u}\ \frac{1}{2}$ ;  $\frac{1}{2}-u, \frac{1}{2}, 0$ ;  $\frac{1}{2}, \frac{1}{2}-u, 0$ .  
 (j)  $u, u+\frac{1}{2}, \frac{1}{2}$ ;  $\bar{u}, \frac{1}{2}-u, \frac{1}{2}$ ;  $u+\frac{1}{2}, u, \frac{1}{2}$ ;  $\frac{1}{2}-u, \bar{u}, \frac{1}{2}$ ;  
 $\frac{1}{2}-u, u, \frac{1}{2}$ ;  $u+\frac{1}{2}, \bar{u}, \frac{1}{2}$ ;  $u, \frac{1}{2}-u, \frac{1}{2}$ ;  $\bar{u}, u+\frac{1}{2}, \frac{1}{2}$ .

Sixteen equivalent positions:

- (k)  $xyz$ ;  $\bar{y}\bar{x}z$ ;  $\bar{x}\bar{y}z$ ;  $y\bar{x}z$ ;  
 $yx\bar{z}$ ;  $x\bar{y}\bar{z}$ ;  $\bar{y}\bar{x}\bar{z}$ ;  $\bar{x}y\bar{z}$ ;  
 $x+\frac{1}{2}, y+\frac{1}{2}, z+\frac{1}{2}$ ;  $\frac{1}{2}-y, x+\frac{1}{2}, z+\frac{1}{2}$ ;  $\frac{1}{2}-x, \frac{1}{2}-y, z+\frac{1}{2}$ ;  
 $y+\frac{1}{2}, \frac{1}{2}-x, z+\frac{1}{2}$ ;  
 $y+\frac{1}{2}, x+\frac{1}{2}, \frac{1}{2}-z$ ;  $x+\frac{1}{2}, \frac{1}{2}-y, \frac{1}{2}-z$ ;  $\frac{1}{2}-y, \frac{1}{2}-x, \frac{1}{2}-z$ ;  
 $\frac{1}{2}-x, y+\frac{1}{2}, \frac{1}{2}-z$ .

SPACE-GROUP  $D_4^{10}$ .\*

Four equivalent positions:

- (a)  $0\ 0\ 0$ ;  $0\ \frac{1}{2}\ \frac{1}{2}$ ;  $\frac{1}{2}\ 0\ \frac{1}{2}$ ;  $\frac{1}{2}\ \frac{1}{2}\ 0$ .  
 (b)  $0\ 0\ \frac{1}{2}$ ;  $0\ \frac{1}{2}\ \frac{1}{2}$ ;  $\frac{1}{2}\ 0\ \frac{1}{2}$ ;  $\frac{1}{2}\ \frac{1}{2}\ 0$ .

Eight equivalent positions:

- (c)  $0\ 0\ u$ ;  $0, \frac{1}{2}, u+\frac{1}{2}$ ;  $\frac{1}{2}, 0, u+\frac{1}{2}$ ;  $\frac{1}{2}, \frac{1}{2}, \frac{1}{2}-u$ ;  
 $0\ 0\ \bar{u}$ ;  $0, \frac{1}{2}, \frac{1}{2}-u$ ;  $\frac{1}{2}, 0, \frac{1}{2}-u$ ;  $\frac{1}{2}, \frac{1}{2}, u+\frac{1}{2}$ .  
 (d)  $u\ u\ 0$ ;  $u, \frac{1}{2}-u, \frac{1}{2}$ ;  $\frac{1}{2}-u, \frac{1}{2}-u, \frac{1}{2}$ ;  $\frac{1}{2}-u, u, \frac{1}{2}$ ;  
 $\bar{u}\ \bar{u}\ 0$ ;  $\bar{u}, u+\frac{1}{2}, \frac{1}{2}$ ;  $u+\frac{1}{2}, u+\frac{1}{2}, \frac{1}{2}$ ;  $u+\frac{1}{2}, \bar{u}, \frac{1}{2}$ .  
 (e)  $u\ \bar{u}\ 0$ ;  $\bar{u}, \frac{1}{2}-u, \frac{1}{2}$ ;  $u+\frac{1}{2}, \frac{1}{2}-u, \frac{1}{2}$ ;  $u+\frac{1}{2}, u, \frac{1}{2}$ ;  
 $\bar{u}\ u\ 0$ ;  $u, u+\frac{1}{2}, \frac{1}{2}$ ;  $\frac{1}{2}-u, u+\frac{1}{2}, \frac{1}{2}$ ;  $\frac{1}{2}-u, \bar{u}, \frac{1}{2}$ .  
 (f)  $u\ \frac{1}{2}\ \frac{1}{2}$ ;  $\frac{1}{2}, \frac{1}{2}-u, \frac{1}{2}$ ;  $\frac{1}{2}-u, \frac{1}{2}, \frac{1}{2}$ ;  $\frac{1}{2}\ u\ \frac{1}{2}$ ;  
 $\bar{u}\ \frac{1}{2}\ \frac{1}{2}$ ;  $\frac{1}{2}, u+\frac{1}{2}, \frac{1}{2}$ ;  $u+\frac{1}{2}, \frac{1}{2}, \frac{1}{2}$ ;  $\frac{1}{2}\ \bar{u}\ \frac{1}{2}$ .

Sixteen equivalent positions:

- (g)  $xyz$ ;  $y, \frac{1}{2}-x, z+\frac{1}{2}$ ;  $\bar{x}\bar{y}z$ ;  $\frac{1}{2}-y, x, z+\frac{1}{2}$ ;  
 $\frac{1}{2}-x, y, \frac{1}{2}-z$ ;  $\frac{1}{2}-y, \frac{1}{2}-x, \frac{1}{2}-z$ ;  $x+\frac{1}{2}, \bar{y}, \frac{1}{2}-z$ ;  $yx\bar{z}$ ;  
 $x+\frac{1}{2}, y+\frac{1}{2}, z+\frac{1}{2}$ ;  $y+\frac{1}{2}, \bar{x}, z+\frac{1}{2}$ ;  $\frac{1}{2}-x, \frac{1}{2}-y, z+\frac{1}{2}$ ;  
 $\bar{y}, x+\frac{1}{2}, z+\frac{1}{2}$ ;  
 $\bar{x}, y+\frac{1}{2}, \frac{1}{2}-z$ ;  $\bar{y}\bar{x}\bar{z}$ ;  $x, \frac{1}{2}-y, \frac{1}{2}-z$ ;  
 $y+\frac{1}{2}, x+\frac{1}{2}, \frac{1}{2}-z$ .

G. HOLOHEDRY.

SPACE-GROUP  $D_{4h}^1$ .

One equivalent position:

- (a)  $0\ 0\ 0$ . (c)  $\frac{1}{2}\ \frac{1}{2}\ 0$ .  
 (b)  $0\ 0\ \frac{1}{2}$ . (d)  $\frac{1}{2}\ \frac{1}{2}\ \frac{1}{2}$ .

Two equivalent positions:

- (e)  $0\ \frac{1}{2}\ \frac{1}{2}$ ;  $\frac{1}{2}\ 0\ \frac{1}{2}$ . (g)  $0\ 0\ u$ ;  $0\ 0\ \bar{u}$ .  
 (f)  $0\ \frac{1}{2}\ 0$ ;  $\frac{1}{2}\ 0\ 0$ . (h)  $\frac{1}{2}\ \frac{1}{2}\ u$ ;  $\frac{1}{2}\ \frac{1}{2}\ \bar{u}$ .

SPACE-GROUP  $D_{4h}^1$  (continued).*Four equivalent positions:*

- (i)  $0 \frac{1}{2} u$ ;  $\frac{1}{2} 0 u$ ;  $\frac{1}{2} 0 \bar{u}$ ;  $0 \frac{1}{2} \bar{u}$ .  
 (j)  $u u 0$ ;  $\bar{u} u 0$ ;  $u \bar{u} 0$ ;  $\bar{u} \bar{u} 0$ .  
 (k)  $u u \frac{1}{2}$ ;  $\bar{u} u \frac{1}{2}$ ;  $u \bar{u} \frac{1}{2}$ ;  $\bar{u} \bar{u} \frac{1}{2}$ .  
 (l)  $u 0 0$ ;  $0 u 0$ ;  $0 \bar{u} 0$ ;  $\bar{u} 0 0$ .  
 (m)  $u 0 \frac{1}{2}$ ;  $0 u \frac{1}{2}$ ;  $0 \bar{u} \frac{1}{2}$ ;  $\bar{u} 0 \frac{1}{2}$ .  
 (n)  $u \frac{1}{2} 0$ ;  $\frac{1}{2} u 0$ ;  $\frac{1}{2} \bar{u} 0$ ;  $\bar{u} \frac{1}{2} 0$ .  
 (o)  $u \frac{1}{2} \frac{1}{2}$ ;  $\frac{1}{2} u \frac{1}{2}$ ;  $\frac{1}{2} \bar{u} \frac{1}{2}$ ;  $\bar{u} \frac{1}{2} \frac{1}{2}$ .

*Eight equivalent positions:*

- (p)  $u v 0$ ;  $\bar{v} u 0$ ;  $v \bar{u} 0$ ;  $\bar{u} \bar{v} 0$ ;  
 $v u 0$ ;  $u \bar{v} 0$ ;  $\bar{u} v 0$ ;  $\bar{v} \bar{u} 0$ .  
 (q)  $u v \frac{1}{2}$ ;  $\bar{v} u \frac{1}{2}$ ;  $v \bar{u} \frac{1}{2}$ ;  $\bar{u} \bar{v} \frac{1}{2}$ ;  
 $v u \frac{1}{2}$ ;  $u \bar{v} \frac{1}{2}$ ;  $\bar{u} v \frac{1}{2}$ ;  $\bar{v} \bar{u} \frac{1}{2}$ .  
 (r)  $u \bar{u} v$ ;  $u u v$ ;  $\bar{u} \bar{u} v$ ;  $\bar{u} u v$ ;  
 $\bar{u} u \bar{v}$ ;  $\bar{u} \bar{u} \bar{v}$ ;  $u u \bar{v}$ ;  $u \bar{u} \bar{v}$ .  
 (s)  $0 u v$ ;  $\bar{u} 0 v$ ;  $u 0 v$ ;  $0 \bar{u} v$ ;  
 $u 0 \bar{v}$ ;  $0 \bar{u} \bar{v}$ ;  $0 u \bar{v}$ ;  $\bar{u} 0 \bar{v}$ .  
 (t)  $\frac{1}{2} u v$ ;  $\bar{u} \frac{1}{2} v$ ;  $u \frac{1}{2} \bar{v}$ ;  $\frac{1}{2} \bar{u} \bar{v}$ ;  
 $u \frac{1}{2} \bar{v}$ ;  $\frac{1}{2} \bar{u} \bar{v}$ ;  $\frac{1}{2} u \bar{v}$ ;  $\bar{u} \frac{1}{2} \bar{v}$ .

*Sixteen equivalent positions:*

- (u)  $xyz$ ;  $\bar{y}xz$ ;  $\bar{x}\bar{y}z$ ;  $y\bar{x}z$ ;  
 $yx\bar{z}$ ;  $x\bar{y}\bar{z}$ ;  $\bar{y}\bar{x}\bar{z}$ ;  $\bar{x}y\bar{z}$ ;  
 $\bar{x}\bar{y}\bar{z}$ ;  $y\bar{x}\bar{z}$ ;  $xy\bar{z}$ ;  $\bar{y}x\bar{z}$ ;  
 $\bar{y}\bar{x}z$ ;  $\bar{x}yz$ ;  $yxz$ ;  $x\bar{y}z$ .

SPACE-GROUP  $D_{4h}^2$ .*Two equivalent positions:*

- (a)  $0 0 0$ ;  $0 0 \frac{1}{2}$ . (c)  $\frac{1}{2} \frac{1}{2} 0$ ;  $\frac{1}{2} \frac{1}{2} \frac{1}{2}$ .  
 (b)  $0 0 \frac{1}{4}$ ;  $0 0 \frac{3}{4}$ . (d)  $\frac{1}{4} \frac{1}{4} \frac{1}{4}$ ;  $\frac{3}{4} \frac{3}{4} \frac{3}{4}$ .

*Four equivalent positions:*

- (e)  $0 \frac{1}{2} 0$ ;  $\frac{1}{2} 0 0$ ;  $0 \frac{1}{2} \frac{1}{2}$ ;  $\frac{1}{2} 0 \frac{1}{2}$ .  
 (f)  $0 \frac{1}{2} \frac{1}{4}$ ;  $\frac{1}{2} 0 \frac{1}{4}$ ;  $\frac{1}{2} 0 \frac{3}{4}$ ;  $0 \frac{1}{2} \frac{3}{4}$ .  
 (g)  $0 0 u$ ;  $0 0 \bar{u}$ ;  $0, 0, \frac{1}{2} - u$ ;  $0, 0, u + \frac{1}{2}$ .  
 (h)  $\frac{1}{2} \frac{1}{2} u$ ;  $\frac{1}{2} \frac{1}{2} \bar{u}$ ;  $\frac{1}{2}, \frac{1}{2}, \frac{1}{2} - u$ ;  $\frac{1}{2}, \frac{1}{2}, u + \frac{1}{2}$ .

*Eight equivalent positions:*

- (i)  $0 \frac{1}{2} u$ ;  $\frac{1}{2} 0 u$ ;  $0, \frac{1}{2}, u + \frac{1}{2}$ ;  $\frac{1}{2}, 0, u + \frac{1}{2}$ ;  
 $0 \frac{1}{2} \bar{u}$ ;  $\frac{1}{2} 0 \bar{u}$ ;  $0, \frac{1}{2}, \frac{1}{2} - u$ ;  $\frac{1}{2}, 0, \frac{1}{2} - u$ .  
 (j)  $u u 0$ ;  $u \bar{u} 0$ ;  $u u \frac{1}{2}$ ;  $u \bar{u} \frac{1}{2}$ ;  
 $\bar{u} \bar{u} 0$ ;  $\bar{u} u 0$ ;  $\bar{u} \bar{u} \frac{1}{2}$ ;  $\bar{u} u \frac{1}{2}$ .  
 (k)  $u 0 0$ ;  $0 u 0$ ;  $u 0 \frac{1}{2}$ ;  $0 u \frac{1}{2}$ ;  
 $\bar{u} 0 0$ ;  $0 \bar{u} 0$ ;  $\bar{u} 0 \frac{1}{2}$ ;  $0 \bar{u} \frac{1}{2}$ .  
 (l)  $u \frac{1}{2} \frac{1}{2}$ ;  $\frac{1}{2} u \frac{1}{2}$ ;  $u \frac{1}{2} 0$ ;  $\frac{1}{2} u 0$ ;  
 $\bar{u} \frac{1}{2} \frac{1}{2}$ ;  $\frac{1}{2} \bar{u} \frac{1}{2}$ ;  $\bar{u} \frac{1}{2} 0$ ;  $\frac{1}{2} \bar{u} 0$ .  
 (m)  $u v \frac{1}{2}$ ;  $v \bar{u} \frac{1}{2}$ ;  $v u \frac{1}{2}$ ;  $u \bar{v} \frac{1}{2}$ ;  
 $\bar{u} \bar{v} \frac{1}{2}$ ;  $\bar{v} u \frac{1}{2}$ ;  $\bar{v} \bar{u} \frac{1}{2}$ ;  $\bar{u} v \frac{1}{2}$ .

SPACE-GROUP  $D_{4h}^2$  (continued).

Sixteen equivalent positions:

- (n)  $xyz$ ;  $\bar{y}xz$ ;  $\bar{x}\bar{y}z$ ;  $y\bar{x}z$ ;  
 $yx\bar{z}$ ;  $x\bar{y}\bar{z}$ ;  $\bar{y}\bar{x}\bar{z}$ ;  $\bar{x}y\bar{z}$ ;  
 $\bar{x}$ ,  $\bar{y}$ ,  $\frac{1}{2}-z$ ;  $y$ ,  $\bar{x}$ ,  $\frac{1}{2}-z$ ;  $x$ ,  $y$ ,  $\frac{1}{2}-z$ ;  $\bar{y}$ ,  $x$ ,  $\frac{1}{2}-z$ ;  
 $\bar{y}$ ,  $\bar{x}$ ,  $z+\frac{1}{2}$ ;  $\bar{x}$ ,  $y$ ,  $z+\frac{1}{2}$ ;  $y$ ,  $x$ ,  $z+\frac{1}{2}$ ;  $x$ ,  $\bar{y}$ ,  $z+\frac{1}{2}$ .

SPACE-GROUP  $D_{4h}^3$ .

Two equivalent positions:

- (a)  $000$ ;  $\frac{1}{2}\frac{1}{2}0$ . (c)  $0\frac{1}{2}0$ ;  $\frac{1}{2}00$ .  
 (b)  $00\frac{1}{2}$ ;  $\frac{1}{2}\frac{1}{2}\frac{1}{2}$ . (d)  $0\frac{1}{2}\frac{1}{2}$ ;  $\frac{1}{2}0\frac{1}{2}$ .

Four equivalent positions:

- (e)  $\frac{1}{2}\frac{1}{2}0$ ;  $\frac{1}{2}\frac{1}{2}0$ ;  $\frac{1}{2}\frac{1}{2}0$ ;  $\frac{1}{2}\frac{1}{2}0$ .  
 (f)  $\frac{1}{2}\frac{1}{2}\frac{1}{2}$ ;  $\frac{1}{2}\frac{1}{2}\frac{1}{2}$ ;  $\frac{1}{2}\frac{1}{2}\frac{1}{2}$ ;  $\frac{1}{2}\frac{1}{2}\frac{1}{2}$ .  
 (g)  $00u$ ;  $00\bar{u}$ ;  $\frac{1}{2}\frac{1}{2}u$ ;  $\frac{1}{2}\frac{1}{2}\bar{u}$ .  
 (h)  $0\frac{1}{2}u$ ;  $\frac{1}{2}0u$ ;  $\frac{1}{2}0\bar{u}$ ;  $0\frac{1}{2}\bar{u}$ .

Eight equivalent positions:

- (i)  $uu0$ ;  $u\bar{u}0$ ;  $u+\frac{1}{2}$ ,  $u+\frac{1}{2}$ ,  $0$ ;  $u+\frac{1}{2}$ ,  $\frac{1}{2}-u$ ,  $0$ ;  
 $\bar{u}\bar{u}0$ ;  $\bar{u}u0$ ;  $\frac{1}{2}-u$ ,  $\frac{1}{2}-u$ ,  $0$ ;  $\frac{1}{2}-u$ ,  $u+\frac{1}{2}$ ,  $0$ .  
 (j)  $uu\frac{1}{2}$ ;  $u\bar{u}\frac{1}{2}$ ;  $u+\frac{1}{2}$ ,  $u+\frac{1}{2}$ ,  $\frac{1}{2}$ ;  $u+\frac{1}{2}$ ,  $\frac{1}{2}-u$ ,  $\frac{1}{2}$ ;  
 $\bar{u}\bar{u}\frac{1}{2}$ ;  $\bar{u}u\frac{1}{2}$ ;  $\frac{1}{2}-u$ ,  $\frac{1}{2}-u$ ,  $\frac{1}{2}$ ;  $\frac{1}{2}-u$ ,  $u+\frac{1}{2}$ ,  $\frac{1}{2}$ .  
 (k)  $u00$ ;  $0u0$ ;  $u+\frac{1}{2}$ ,  $\frac{1}{2}$ ,  $0$ ;  $\frac{1}{2}$ ,  $u+\frac{1}{2}$ ,  $0$ ;  
 $\bar{u}00$ ;  $0\bar{u}0$ ;  $\frac{1}{2}-u$ ,  $\frac{1}{2}$ ,  $0$ ;  $\frac{1}{2}$ ,  $\frac{1}{2}-u$ ,  $0$ .  
 (l)  $u\frac{1}{2}\frac{1}{2}$ ;  $\frac{1}{2}u\frac{1}{2}$ ;  $u+\frac{1}{2}$ ,  $0$ ,  $\frac{1}{2}$ ;  $0$ ,  $u+\frac{1}{2}$ ,  $\frac{1}{2}$ ;  
 $\bar{u}\frac{1}{2}\frac{1}{2}$ ;  $\frac{1}{2}\bar{u}\frac{1}{2}$ ;  $\frac{1}{2}-u$ ,  $0$ ,  $\frac{1}{2}$ ;  $0$ ,  $\frac{1}{2}-u$ ,  $\frac{1}{2}$ .  
 (m)  $u$ ,  $\frac{1}{2}-u$ ,  $v$ ;  $u+\frac{1}{2}$ ,  $u$ ,  $v$ ;  $\frac{1}{2}-u$ ,  $\bar{u}$ ,  $v$ ;  $\bar{u}$ ,  $u+\frac{1}{2}$ ,  $v$ ;  
 $\frac{1}{2}-u$ ,  $u$ ,  $\bar{v}$ ;  $\bar{u}$ ,  $\frac{1}{2}-u$ ,  $\bar{v}$ ;  $u$ ,  $u+\frac{1}{2}$ ,  $\bar{v}$ ;  $u+\frac{1}{2}$ ,  $\bar{u}$ ,  $\bar{v}$ .

Sixteen equivalent positions:

- (n)  $xyz$ ;  $\bar{y}xz$ ;  $\bar{x}\bar{y}z$ ;  $y\bar{x}z$ ;  
 $yx\bar{z}$ ;  $x\bar{y}\bar{z}$ ;  $\bar{y}\bar{x}\bar{z}$ ;  $\bar{x}y\bar{z}$ ;  
 $\frac{1}{2}-x$ ,  $\frac{1}{2}-y$ ,  $\bar{z}$ ;  $y+\frac{1}{2}$ ,  $\frac{1}{2}-x$ ,  $\bar{z}$ ;  $x+\frac{1}{2}$ ,  $y+\frac{1}{2}$ ,  $\bar{z}$ ;  $\frac{1}{2}-y$ ,  $x+\frac{1}{2}$ ,  $\bar{z}$ ;  
 $\frac{1}{2}-y$ ,  $\frac{1}{2}-x$ ,  $z$ ;  $\frac{1}{2}-x$ ,  $y+\frac{1}{2}$ ,  $z$ ;  $y+\frac{1}{2}$ ,  $x+\frac{1}{2}$ ,  $z$ ;  $x+\frac{1}{2}$ ,  $\frac{1}{2}-y$ ,  $z$ .

SPACE-GROUP  $D_{4h}^4$ .

Two equivalent positions:

- (a)  $000$ ;  $\frac{1}{2}\frac{1}{2}\frac{1}{2}$ . (b)  $00\frac{1}{2}$ ;  $\frac{1}{2}\frac{1}{2}0$ .

Four equivalent positions:

- (c)  $\frac{1}{2}00$ ;  $0\frac{1}{2}0$ ;  $0\frac{1}{2}\frac{1}{2}$ ;  $\frac{1}{2}0\frac{1}{2}$ .  
 (d)  $\frac{1}{2}0\frac{1}{2}$ ;  $0\frac{1}{2}\frac{1}{2}$ ;  $0\frac{1}{2}\frac{1}{2}$ ;  $\frac{1}{2}0\frac{1}{2}$ .  
 (e)  $00u$ ;  $00\bar{u}$ ;  $\frac{1}{2}$ ,  $\frac{1}{2}$ ,  $\frac{1}{2}-u$ ;  $\frac{1}{2}$ ,  $\frac{1}{2}$ ,  $u+\frac{1}{2}$ .

Eight equivalent positions:

- (f)  $\frac{1}{2}\frac{1}{2}\frac{1}{2}$ ;  $\frac{1}{2}\frac{1}{2}\frac{1}{2}$ ;  $\frac{1}{2}\frac{1}{2}\frac{1}{2}$ ;  $\frac{1}{2}\frac{1}{2}\frac{1}{2}$ ;  
 $\frac{1}{2}\frac{1}{2}\frac{1}{2}$ ;  $\frac{1}{2}\frac{1}{2}\frac{1}{2}$ ;  $\frac{1}{2}\frac{1}{2}\frac{1}{2}$ ;  $\frac{1}{2}\frac{1}{2}\frac{1}{2}$ .



SPACE-GROUP  $D_{4h}^4$  (continued).

- (g)  $\frac{1}{2} 0 u$ ;  $0 \frac{1}{2} u$ ;  $0, \frac{1}{2}, u + \frac{1}{2}$ ;  $\frac{1}{2}, 0, u + \frac{1}{2}$ ;  
 $\frac{1}{2} 0 \bar{u}$ ;  $0 \frac{1}{2} \bar{u}$ ;  $0, \frac{1}{2}, \frac{1}{2} - u$ ;  $\frac{1}{2}, 0, \frac{1}{2} - u$ .  
 (h)  $u u 0$ ;  $u \bar{u} 0$ ;  $u + \frac{1}{2}, \frac{1}{2} - u, \frac{1}{2}$ ;  $u + \frac{1}{2}, u + \frac{1}{2}, \frac{1}{2}$ ;  
 $\bar{u} \bar{u} 0$ ;  $\bar{u} u 0$ ;  $\frac{1}{2} - u, u + \frac{1}{2}, \frac{1}{2}$ ;  $\frac{1}{2} - u, \frac{1}{2} - u, \frac{1}{2}$ .  
 (i)  $u 0 0$ ;  $0 u 0$ ;  $\frac{1}{2}, u + \frac{1}{2}, \frac{1}{2}$ ;  $u + \frac{1}{2}, \frac{1}{2}, \frac{1}{2}$ ;  
 $\bar{u} 0 0$ ;  $0 \bar{u} 0$ ;  $\frac{1}{2}, \frac{1}{2} - u, \frac{1}{2}$ ;  $\frac{1}{2} - u, \frac{1}{2}, \frac{1}{2}$ .  
 (j)  $u 0 \frac{1}{2}$ ;  $0 u \frac{1}{2}$ ;  $\frac{1}{2}, u + \frac{1}{2}, 0$ ;  $u + \frac{1}{2}, \frac{1}{2}, 0$ ;  
 $\bar{u} 0 \frac{1}{2}$ ;  $0 \bar{u} \frac{1}{2}$ ;  $\frac{1}{2}, \frac{1}{2} - u, 0$ ;  $\frac{1}{2} - u, \frac{1}{2}, 0$ .

Sixteen equivalent positions:

- (k)  $xyz$ ;  $\bar{y}xz$ ;  $\bar{x}\bar{y}z$ ;  $y\bar{x}z$ ;  
 $yx\bar{z}$ ;  $x\bar{y}\bar{z}$ ;  $\bar{y}\bar{x}\bar{z}$ ;  $\bar{x}y\bar{z}$ ;  
 $\frac{1}{2} - x, \frac{1}{2} - y, \frac{1}{2} - z$ ;  $y + \frac{1}{2}, \frac{1}{2} - x, \frac{1}{2} - z$ ;  $x + \frac{1}{2}, y + \frac{1}{2}, \frac{1}{2} - z$ ;  
 $\frac{1}{2} - y, x + \frac{1}{2}, \frac{1}{2} - z$ ;  
 $\frac{1}{2} - y, \frac{1}{2} - x, z + \frac{1}{2}$ ;  $\frac{1}{2} - x, y + \frac{1}{2}, z + \frac{1}{2}$ ;  $y + \frac{1}{2}, x + \frac{1}{2}, z + \frac{1}{2}$ ;  
 $x + \frac{1}{2}, \frac{1}{2} - y, z + \frac{1}{2}$ .

SPACE-GROUP  $D_{4h}^5$ .

Two equivalent positions:

- (a)  $0 0 0$ ;  $\frac{1}{2} \frac{1}{2} 0$ . (c)  $0 \frac{1}{2} \frac{1}{2}$ ;  $\frac{1}{2} 0 \frac{1}{2}$ .  
 (b)  $\frac{1}{2} \frac{1}{2} \frac{1}{2}$ ;  $0 0 \frac{1}{2}$ . (d)  $\frac{1}{2} 0 0$ ;  $0 \frac{1}{2} 0$ .

Four equivalent positions:

- (e)  $0 0 u$ ;  $0 0 \bar{u}$ ;  $\frac{1}{2} \frac{1}{2} \bar{u}$ ;  $\frac{1}{2} \frac{1}{2} u$ .  
 (f)  $0 \frac{1}{2} u$ ;  $0 \frac{1}{2} \bar{u}$ ;  $\frac{1}{2} 0 \bar{u}$ ;  $\frac{1}{2} 0 u$ .  
 (g)  $u, u + \frac{1}{2}, 0$ ;  $\frac{1}{2} - u, u, 0$ ;  $u + \frac{1}{2}, \bar{u}, 0$ ;  $\bar{u}, \frac{1}{2} - u, 0$ .  
 (h)  $u, u + \frac{1}{2}, \frac{1}{2}$ ;  $\frac{1}{2} - u, u, \frac{1}{2}$ ;  $u + \frac{1}{2}, \bar{u}, \frac{1}{2}$ ;  $\bar{u}, \frac{1}{2} - u, \frac{1}{2}$ .

Eight equivalent positions:

- (i)  $u v 0$ ;  $v \bar{u} 0$ ;  $v + \frac{1}{2}, u + \frac{1}{2}, 0$ ;  $u + \frac{1}{2}, \frac{1}{2} - v, 0$ ;  
 $\bar{u} \bar{v} 0$ ;  $\bar{v} u 0$ ;  $\frac{1}{2} - v, \frac{1}{2} - u, 0$ ;  $\frac{1}{2} - u, v + \frac{1}{2}, 0$ .  
 (j)  $u v \frac{1}{2}$ ;  $v \bar{u} \frac{1}{2}$ ;  $v + \frac{1}{2}, u + \frac{1}{2}, \frac{1}{2}$ ;  $u + \frac{1}{2}, \frac{1}{2} - v, \frac{1}{2}$ ;  
 $\bar{u} \bar{v} \frac{1}{2}$ ;  $\bar{v} u \frac{1}{2}$ ;  $\frac{1}{2} - v, \frac{1}{2} - u, \frac{1}{2}$ ;  $\frac{1}{2} - u, v + \frac{1}{2}, \frac{1}{2}$ .  
 (k)  $u, \frac{1}{2} - u, v$ ;  $u + \frac{1}{2}, u, v$ ;  $\frac{1}{2} - u, \bar{u}, v$ ;  $\bar{u}, u + \frac{1}{2}, v$ ;  
 $\bar{u}, u + \frac{1}{2}, \bar{v}$ ;  $\frac{1}{2} - u, \bar{u}, \bar{v}$ ;  $u + \frac{1}{2}, u, \bar{v}$ ;  $u, \frac{1}{2} - u, \bar{v}$ .

Sixteen equivalent positions:

- (l)  $xyz$ ;  $\bar{y}xz$ ;  $\bar{x}\bar{y}z$ ;  $y\bar{x}z$ ;  
 $y + \frac{1}{2}, x + \frac{1}{2}, \bar{z}$ ;  $x + \frac{1}{2}, \frac{1}{2} - y, \bar{z}$ ;  $\frac{1}{2} - y, \frac{1}{2} - x, \bar{z}$ ;  $\frac{1}{2} - x, y + \frac{1}{2}, \bar{z}$ ;  
 $\bar{x}\bar{y}\bar{z}$ ;  $y\bar{x}\bar{z}$ ;  $x\bar{y}\bar{z}$ ;  $\bar{y}x\bar{z}$ ;  
 $\frac{1}{2} - y, \frac{1}{2} - x, z$ ;  $\frac{1}{2} - x, y + \frac{1}{2}, z$ ;  $y + \frac{1}{2}, x + \frac{1}{2}, z$ ;  $x + \frac{1}{2}, \frac{1}{2} - y, z$ .

SPACE-GROUP  $D_{4h}^6$ .

Two equivalent positions:

- (a)  $0 0 0$ ;  $\frac{1}{2} \frac{1}{2} \frac{1}{2}$ . (b)  $0 0 \frac{1}{2}$ ;  $\frac{1}{2} \frac{1}{2} 0$

SPACE-GROUP  $D_{4h}^6$  (continued).

Four equivalent positions:

- (c)  $0 \frac{1}{2} 0$ ;  $\frac{1}{2} 0 0$ ;  $\frac{1}{2} 0 \frac{1}{2}$ ;  $0 \frac{1}{2} \frac{1}{2}$ .  
 (d)  $0 \frac{1}{2} \frac{1}{2}$ ;  $\frac{1}{2} 0 \frac{1}{2}$ ;  $0 \frac{1}{2} \frac{1}{2}$ ;  $\frac{1}{2} 0 \frac{1}{2}$ .  
 (e)  $0 0 u$ ;  $0 0 \bar{u}$ ;  $\frac{1}{2}, \frac{1}{2}, u + \frac{1}{2}$ ;  $\frac{1}{2}, \frac{1}{2}, \frac{1}{2} - u$ .

Eight equivalent positions:

- (f)  $0 \frac{1}{2} u$ ;  $\frac{1}{2} 0 u$ ;  $\frac{1}{2}, 0, u + \frac{1}{2}$ ;  $0, \frac{1}{2}, u + \frac{1}{2}$ ;  
 $0 \frac{1}{2} \bar{u}$ ;  $\frac{1}{2} 0 \bar{u}$ ;  $\frac{1}{2}, 0, \frac{1}{2} - u$ ;  $0, \frac{1}{2}, \frac{1}{2} - u$ .  
 (g)  $u, u + \frac{1}{2}, \frac{1}{2}$ ;  $u + \frac{1}{2}, \bar{u}, \frac{1}{2}$ ;  $\bar{u}, \frac{1}{2} - u, \frac{1}{2}$ ;  $\frac{1}{2} - u, u, \frac{1}{2}$ ;  
 $u, u + \frac{1}{2}, \frac{1}{2}$ ;  $u + \frac{1}{2}, \bar{u}, \frac{1}{2}$ ;  $\bar{u}, \frac{1}{2} - u, \frac{1}{2}$ ;  $\frac{1}{2} - u, u, \frac{1}{2}$ .  
 (h)  $u v 0$ ;  $v \bar{u} 0$ ;  $v + \frac{1}{2}, u + \frac{1}{2}, \frac{1}{2}$ ;  $u + \frac{1}{2}, \frac{1}{2} - v, \frac{1}{2}$ ;  
 $\bar{u} v 0$ ;  $v \bar{u} 0$ ;  $\frac{1}{2} - v, \frac{1}{2} - u, \frac{1}{2}$ ;  $\frac{1}{2} - u, v + \frac{1}{2}, \frac{1}{2}$ .

Sixteen equivalent positions:

- (i)  $xyz$ ;  $y\bar{x}z$ ;  $\bar{x}\bar{y}z$ ;  $\bar{y}xz$ ;  
 $xy\bar{z}$ ;  $y\bar{x}\bar{z}$ ;  $\bar{x}\bar{y}\bar{z}$ ;  $\bar{y}x\bar{z}$ ;  
 $\frac{1}{2} - x, y + \frac{1}{2}, z + \frac{1}{2}$ ;  $\frac{1}{2} - y, \frac{1}{2} - x, z + \frac{1}{2}$ ;  $x + \frac{1}{2}, \frac{1}{2} - y, z + \frac{1}{2}$ ;  
 $y + \frac{1}{2}, x + \frac{1}{2}, z + \frac{1}{2}$ ;  
 $\frac{1}{2} - x, y + \frac{1}{2}, \frac{1}{2} - z$ ;  $\frac{1}{2} - y, \frac{1}{2} - x, \frac{1}{2} - z$ ;  $x + \frac{1}{2}, \frac{1}{2} - y, \frac{1}{2} - z$ ;  
 $y + \frac{1}{2}, x + \frac{1}{2}, \frac{1}{2} - z$ .

SPACE-GROUP  $D_{4h}^7$ .\*

Two equivalent positions:

- (a)  $0 0 0$ ;  $\frac{1}{2} \frac{1}{2} 0$ . (c)  $0 \frac{1}{2} u$ ;  $\frac{1}{2} 0 \bar{u}$ .  
 (b)  $0 0 \frac{1}{2}$ ;  $\frac{1}{2} \frac{1}{2} \frac{1}{2}$ .

Four equivalent positions:

- (d)  $\frac{1}{2} \frac{1}{2} 0$ ;  $\frac{1}{2} \frac{1}{2} 0$ ;  $\frac{1}{2} \frac{1}{2} 0$ ;  $\frac{1}{2} \frac{1}{2} 0$ .  
 (e)  $\frac{1}{2} \frac{1}{2} \frac{1}{2}$ ;  $\frac{1}{2} \frac{1}{2} \frac{1}{2}$ ;  $\frac{1}{2} \frac{1}{2} \frac{1}{2}$ ;  $\frac{1}{2} \frac{1}{2} \frac{1}{2}$ .  
 (f)  $0 0 u$ ;  $0 0 \bar{u}$ ;  $\frac{1}{2} \frac{1}{2} \bar{u}$ ;  $\frac{1}{2} \frac{1}{2} u$ .

Eight equivalent positions:

- (g)  $u u 0$ ;  $u \bar{u} 0$ ;  $u + \frac{1}{2}, \frac{1}{2} - u, 0$ ;  $u + \frac{1}{2}, u + \frac{1}{2}, 0$ ;  
 $\bar{u} \bar{u} 0$ ;  $\bar{u} u 0$ ;  $\frac{1}{2} - u, u + \frac{1}{2}, 0$ ;  $\frac{1}{2} - u, \frac{1}{2} - u, 0$ .  
 (h)  $u u \frac{1}{2}$ ;  $u \bar{u} \frac{1}{2}$ ;  $u + \frac{1}{2}, \frac{1}{2} - u, \frac{1}{2}$ ;  $u + \frac{1}{2}, u + \frac{1}{2}, \frac{1}{2}$ ;  
 $\bar{u} \bar{u} \frac{1}{2}$ ;  $\bar{u} u \frac{1}{2}$ ;  $\frac{1}{2} - u, u + \frac{1}{2}, \frac{1}{2}$ ;  $\frac{1}{2} - u, \frac{1}{2} - u, \frac{1}{2}$ .  
 (i)  $u 0 v$ ;  $0 u \bar{v}$ ;  $u + \frac{1}{2}, \frac{1}{2}, \bar{v}$ ;  $\frac{1}{2}, u + \frac{1}{2}, v$ ;  
 $\bar{u} 0 v$ ;  $0 \bar{u} \bar{v}$ ;  $\frac{1}{2} - u, \frac{1}{2}, \bar{v}$ ;  $\frac{1}{2}, \frac{1}{2} - u, v$ .  
 (j)  $u, u + \frac{1}{2}, v$ ;  $u, \frac{1}{2} - u, v$ ;  $\bar{u}, \frac{1}{2} - u, v$ ;  $\bar{u}, u + \frac{1}{2}, v$ ;  
 $u + \frac{1}{2}, u, \bar{v}$ ;  $u + \frac{1}{2}, \bar{u}, \bar{v}$ ;  $\frac{1}{2} - u, \bar{u}, \bar{v}$ ;  $\frac{1}{2} - u, u, \bar{v}$ .

Sixteen equivalent positions:

- (k)  $xyz$ ;  $y + \frac{1}{2}, \frac{1}{2} - x, z$ ;  $\bar{x}\bar{y}z$ ;  $\frac{1}{2} - y, x + \frac{1}{2}, z$ ;  
 $x + \frac{1}{2}, y + \frac{1}{2}, \bar{z}$ ;  $y\bar{x}\bar{z}$ ;  $\frac{1}{2} - x, \frac{1}{2} - y, \bar{z}$ ;  $\bar{y}x\bar{z}$ ;  
 $\bar{x}yz$ ;  $\frac{1}{2} - y, \frac{1}{2} - x, z$ ;  $x\bar{y}z$ ;  $y + \frac{1}{2}, x + \frac{1}{2}, z$ ;  
 $\frac{1}{2} - x, y + \frac{1}{2}, \bar{z}$ ;  $\bar{y}\bar{x}\bar{z}$ ;  $x + \frac{1}{2}, \frac{1}{2} - y, \bar{z}$ ;  $yx\bar{z}$ .

SPACE-GROUP  $D_{4h}^8$ .\**Four equivalent positions:*

- (a)  $000$ ;  $\frac{1}{2}\frac{1}{2}0$ ;  $\frac{1}{2}\frac{1}{2}\frac{1}{2}$ ;  $00\frac{1}{2}$ .  
 (b)  $00\frac{1}{2}$ ;  $\frac{1}{2}\frac{1}{2}\frac{1}{2}$ ;  $00\frac{1}{2}$ ;  $\frac{1}{2}\frac{1}{2}\frac{1}{2}$ .  
 (c)  $0\frac{1}{2}u$ ;  $\frac{1}{2}0\bar{u}$ ;  $\frac{1}{2}, 0, \frac{1}{2}-u$ ;  $0, \frac{1}{2}, u+\frac{1}{2}$ .

*Eight equivalent positions:*

- (d)  $\frac{1}{2}\frac{1}{2}\frac{1}{2}$ ;  $\frac{1}{2}\frac{1}{2}\frac{1}{2}$ ;  $\frac{1}{2}\frac{1}{2}\frac{1}{2}$ ;  $\frac{1}{2}\frac{1}{2}\frac{1}{2}$ ;  
 $\frac{1}{2}\frac{1}{2}\frac{1}{2}$ ;  $\frac{1}{2}\frac{1}{2}\frac{1}{2}$ ;  $\frac{1}{2}\frac{1}{2}\frac{1}{2}$ ;  $\frac{1}{2}\frac{1}{2}\frac{1}{2}$ .  
 (e)  $00u$ ;  $\frac{1}{2}\frac{1}{2}u$ ;  $\frac{1}{2}, \frac{1}{2}, u+\frac{1}{2}$ ;  $0, 0, u+\frac{1}{2}$ ;  
 $00\bar{u}$ ;  $\frac{1}{2}\frac{1}{2}\bar{u}$ ;  $\frac{1}{2}, \frac{1}{2}, \frac{1}{2}-u$ ;  $0, 0, \frac{1}{2}-u$ .  
 (f)  $uu0$ ;  $u\bar{u}\frac{1}{2}$ ;  $u+\frac{1}{2}, \frac{1}{2}-u, 0$ ;  $u+\frac{1}{2}, u+\frac{1}{2}, \frac{1}{2}$ ;  
 $\bar{u}\bar{u}0$ ;  $\bar{u}u\frac{1}{2}$ ;  $\frac{1}{2}-u, u+\frac{1}{2}, 0$ ;  $\frac{1}{2}-u, \frac{1}{2}-u, \frac{1}{2}$ .

*Sixteen equivalent positions:*

- (g)  $xyz$ ;  $y+\frac{1}{2}, \frac{1}{2}-x, z$ ;  $\bar{x}\bar{y}z$ ;  $\frac{1}{2}-y, x+\frac{1}{2}, z$ ;  
 $x+\frac{1}{2}, y+\frac{1}{2}, \frac{1}{2}-z$ ;  $y, \bar{x}, \frac{1}{2}-z$ ;  $\frac{1}{2}-x, \frac{1}{2}-y, \frac{1}{2}-z$ ;  $\bar{y}, x, \frac{1}{2}-z$ ;  
 $\bar{x}, y, z+\frac{1}{2}$ ;  $\frac{1}{2}-y, \frac{1}{2}-x, z+\frac{1}{2}$ ;  $x, \bar{y}, z+\frac{1}{2}$ ;  $y+\frac{1}{2}, x+\frac{1}{2}, z+\frac{1}{2}$ ;  
 $\frac{1}{2}-x, y+\frac{1}{2}, \bar{z}$ ;  $\bar{y}\bar{x}\bar{z}$ ;  $x+\frac{1}{2}, \frac{1}{2}-y, \bar{z}$ ;  $yx\bar{z}$ .

SPACE-GROUP  $D_{4h}^9$ .\*

According to the previous definitions (page 33), this space group is  $D_{4h}^{10}$  and the following one is  $D_{4h}^9$ . The two are here interchanged to conform with Niggli's descriptions.

*Two equivalent positions:*

- (a)  $000$ ;  $00\frac{1}{2}$ . (d)  $0\frac{1}{2}\frac{1}{2}$ ;  $\frac{1}{2}00$ .  
 (b)  $\frac{1}{2}\frac{1}{2}0$ ;  $\frac{1}{2}\frac{1}{2}\frac{1}{2}$ . (e)  $00\frac{1}{2}$ ;  $00\frac{1}{2}$ .  
 (c)  $0\frac{1}{2}0$ ;  $\frac{1}{2}0\frac{1}{2}$ . (f)  $\frac{1}{2}\frac{1}{2}\frac{1}{2}$ ;  $\frac{1}{2}\frac{1}{2}\frac{1}{2}$ .

*Four equivalent positions:*

- (g)  $00u$ ;  $00\bar{u}$ ;  $0, 0, u+\frac{1}{2}$ ;  $0, 0, \frac{1}{2}-u$ .  
 (h)  $\frac{1}{2}\frac{1}{2}u$ ;  $\frac{1}{2}\frac{1}{2}\bar{u}$ ;  $\frac{1}{2}, \frac{1}{2}, u+\frac{1}{2}$ ;  $\frac{1}{2}, \frac{1}{2}, \frac{1}{2}-u$ .  
 (i)  $0\frac{1}{2}u$ ;  $0\frac{1}{2}\bar{u}$ ;  $\frac{1}{2}, 0, \frac{1}{2}-u$ ;  $\frac{1}{2}, 0, u+\frac{1}{2}$ .  
 (j)  $u00$ ;  $\bar{u}00$ ;  $0\bar{u}\frac{1}{2}$ ;  $0u\frac{1}{2}$ .  
 (k)  $u\frac{1}{2}\frac{1}{2}$ ;  $\bar{u}\frac{1}{2}\frac{1}{2}$ ;  $\frac{1}{2}\bar{u}0$ ;  $\frac{1}{2}u0$ .  
 (l)  $u0\frac{1}{2}$ ;  $0\bar{u}0$ ;  $\bar{u}0\frac{1}{2}$ ;  $0u0$ .  
 (m)  $u\frac{1}{2}0$ ;  $\frac{1}{2}\bar{u}\frac{1}{2}$ ;  $\bar{u}\frac{1}{2}0$ ;  $\frac{1}{2}u\frac{1}{2}$ .

*Eight equivalent positions:*

- (n)  $uu\frac{1}{2}$ ;  $u\bar{u}\frac{1}{2}$ ;  $\bar{u}\bar{u}\frac{1}{2}$ ;  $\bar{u}u\frac{1}{2}$ ;  
 $uu\frac{1}{2}$ ;  $u\bar{u}\frac{1}{2}$ ;  $\bar{u}\bar{u}\frac{1}{2}$ ;  $\bar{u}u\frac{1}{2}$ .  
 (o)  $0uv$ ;  $u, 0, v+\frac{1}{2}$ ;  $0\bar{u}v$ ;  $\bar{u}, 0, v+\frac{1}{2}$ ;  
 $0u\bar{v}$ ;  $u, 0, \frac{1}{2}-v$ ;  $0\bar{u}\bar{v}$ ;  $\bar{u}, 0, \frac{1}{2}-v$ .  
 (p)  $\frac{1}{2}uv$ ;  $u, \frac{1}{2}, v+\frac{1}{2}$ ;  $\frac{1}{2}\bar{u}v$ ;  $\bar{u}, \frac{1}{2}, v+\frac{1}{2}$ ;  
 $\frac{1}{2}u\bar{v}$ ;  $u, \frac{1}{2}, \frac{1}{2}-v$ ;  $\frac{1}{2}\bar{u}\bar{v}$ ;  $\bar{u}, \frac{1}{2}, \frac{1}{2}-v$ .  
 (q)  $uv0$ ;  $v\bar{u}\frac{1}{2}$ ;  $\bar{u}\bar{v}0$ ;  $\bar{v}u\frac{1}{2}$ ;  
 $\bar{u}v0$ ;  $\bar{v}\bar{u}\frac{1}{2}$ ;  $u\bar{v}0$ ;  $v u\frac{1}{2}$ .

SPACE-GROUP  $D_{4h}^9$  (continued).

Sixteen equivalent positions:

- (r)  $xyz$ ;  $y, \bar{x}, z+\frac{1}{2}$ ;  $\bar{x}\bar{y}z$ ;  $\bar{y}, x, z+\frac{1}{2}$ ;  
 $xy\bar{z}$ ;  $y, \bar{x}, \frac{1}{2}-z$ ;  $\bar{x}\bar{y}\bar{z}$ ;  $\bar{y}, x, \frac{1}{2}-z$ ;  
 $\bar{x}yz$ ;  $\bar{y}, \bar{x}, z+\frac{1}{2}$ ;  $x\bar{y}z$ ;  $y, x, z+\frac{1}{2}$ ;  
 $\bar{x}y\bar{z}$ ;  $\bar{y}, \bar{x}, \frac{1}{2}-z$ ;  $x\bar{y}\bar{z}$ ;  $y, x, \frac{1}{2}-z$ .

SPACE-GROUP  $D_{4h}^{10}$ .\*

According to the previous definitions this group is  $D_{4h}^9$ .

Two equivalent positions:

- (a)  $000$ ;  $00\frac{1}{2}$ . (c)  $\frac{1}{2}\frac{1}{2}\frac{1}{2}$ ;  $\frac{1}{2}\frac{1}{2}0$ .  
 (b)  $00\frac{1}{4}$ ;  $00\frac{3}{4}$ . (d)  $\frac{1}{4}\frac{1}{4}\frac{1}{4}$ ;  $\frac{1}{4}\frac{1}{4}\frac{3}{4}$ .

Four equivalent positions:

- (e)  $0\frac{1}{2}0$ ;  $\frac{1}{2}0\frac{1}{2}$ ;  $\frac{1}{2}00$ ;  $0\frac{1}{2}\frac{1}{2}$ .  
 (f)  $0\frac{1}{2}\frac{1}{4}$ ;  $\frac{1}{2}0\frac{3}{4}$ ;  $0\frac{1}{2}\frac{3}{4}$ ;  $\frac{1}{2}0\frac{1}{4}$ .  
 (g)  $00u$ ;  $00\bar{u}$ ;  $0, 0, u+\frac{1}{2}$ ;  $0, 0, \frac{1}{2}-u$ .  
 (h)  $\frac{1}{2}\frac{1}{2}u$ ;  $\frac{1}{2}\frac{1}{2}\bar{u}$ ;  $\frac{1}{2}, \frac{1}{2}, u+\frac{1}{2}$ ;  $\frac{1}{2}, \frac{1}{2}, \frac{1}{2}-u$ .  
 (i)  $uu\frac{1}{2}$ ;  $u\bar{u}\frac{3}{2}$ ;  $\bar{u}\bar{u}\frac{1}{2}$ ;  $\bar{u}u\frac{3}{2}$ .  
 (j)  $uu\frac{3}{2}$ ;  $u\bar{u}\frac{1}{2}$ ;  $\bar{u}\bar{u}\frac{3}{2}$ ;  $\bar{u}u\frac{1}{2}$ .

Eight equivalent positions:

- (k)  $0\frac{1}{2}u$ ;  $\frac{1}{2}0u$ ;  $\frac{1}{2}, 0, u+\frac{1}{2}$ ;  $0, \frac{1}{2}, u+\frac{1}{2}$ ;  
 $0\frac{1}{2}\bar{u}$ ;  $\frac{1}{2}0\bar{u}$ ;  $\frac{1}{2}, 0, \frac{1}{2}-u$ ;  $0, \frac{1}{2}, \frac{1}{2}-u$ .  
 (l)  $u00$ ;  $0u\frac{1}{2}$ ;  $u0\frac{1}{2}$ ;  $0u0$ ;  
 $\bar{u}00$ ;  $0\bar{u}\frac{1}{2}$ ;  $\bar{u}0\frac{1}{2}$ ;  $0\bar{u}0$ .  
 (m)  $u\frac{1}{2}\frac{1}{2}$ ;  $\frac{1}{2}u0$ ;  $u\frac{1}{2}0$ ;  $\frac{1}{2}u\frac{1}{2}$ ;  
 $\bar{u}\frac{1}{2}\frac{1}{2}$ ;  $\frac{1}{2}\bar{u}0$ ;  $\bar{u}\frac{1}{2}0$ ;  $\frac{1}{2}\bar{u}\frac{1}{2}$ .  
 (n)  $uv\frac{1}{2}$ ;  $v\bar{u}\frac{3}{2}$ ;  $\bar{u}v\frac{1}{2}$ ;  $v\bar{u}\frac{3}{2}$ ;  
 $\bar{u}v\frac{3}{2}$ ;  $v\bar{u}\frac{1}{2}$ ;  $u\bar{v}\frac{3}{2}$ ;  $v\bar{u}\frac{1}{2}$ .  
 (o)  $uuv$ ;  $\bar{u}\bar{u}v$ ;  $u, \bar{u}, v+\frac{1}{2}$ ;  $\bar{u}, u, v+\frac{1}{2}$ ;  
 $\bar{u}u\bar{v}$ ;  $u\bar{u}\bar{v}$ ;  $\bar{u}, \bar{u}, \frac{1}{2}-v$ ;  $u, u, \frac{1}{2}-v$ .

Sixteen equivalent positions:

- (p)  $xyz$ ;  $y, \bar{x}, z+\frac{1}{2}$ ;  $\bar{x}\bar{y}z$ ;  $\bar{y}, x, z+\frac{1}{2}$ ;  
 $x, y, \frac{1}{2}-z$ ;  $y\bar{x}\bar{z}$ ;  $\bar{x}, \bar{y}, \frac{1}{2}-z$ ;  $\bar{y}x\bar{z}$ ;  
 $\bar{x}, y, z+\frac{1}{2}$ ;  $\bar{y}\bar{x}z$ ;  $x, \bar{y}, z+\frac{1}{2}$ ;  $yxz$ ;  
 $\bar{x}y\bar{z}$ ;  $\bar{y}, \bar{x}, \frac{1}{2}-z$ ;  $x\bar{y}\bar{z}$ ;  $y, x, \frac{1}{2}-z$ .

SPACE-GROUP  $D_{4h}^{11}$ .\*

The space-groups  $D_{4h}^{11}$  and  $D_{4h}^{12}$  are interchanged to conform with the descriptions of Niggli.

Four equivalent positions:

- (a)  $000$ ;  $00\frac{1}{2}$ ;  $\frac{1}{2}\frac{1}{2}0$ ;  $\frac{1}{2}\frac{1}{2}\frac{1}{2}$ .  
 (b)  $0\frac{1}{2}0$ ;  $\frac{1}{2}0\frac{1}{2}$ ;  $\frac{1}{2}00$ ;  $0\frac{1}{2}\frac{1}{2}$ .  
 (c)  $00\frac{1}{4}$ ;  $00\frac{3}{4}$ ;  $\frac{1}{4}\frac{1}{4}\frac{1}{4}$ ;  $\frac{1}{4}\frac{1}{4}\frac{3}{4}$ .  
 (d)  $0\frac{1}{4}\frac{1}{4}$ ;  $\frac{1}{4}0\frac{3}{4}$ ;  $\frac{1}{4}0\frac{1}{4}$ ;  $0\frac{1}{4}\frac{3}{4}$ .

SPACE-GROUP  $D_{4h}^{11}$  (continued).

Eight equivalent positions:

- (e)  $\frac{1}{2}\frac{1}{2}0$ ;  $\frac{1}{2}\frac{2}{2}\frac{1}{2}$ ;  $\frac{2}{2}\frac{2}{2}0$ ;  $\frac{2}{2}\frac{1}{2}\frac{1}{2}$ ;  
 $\frac{1}{2}\frac{1}{2}\frac{1}{2}$ ;  $\frac{1}{2}\frac{2}{2}0$ ;  $\frac{2}{2}\frac{2}{2}\frac{1}{2}$ ;  $\frac{2}{2}\frac{1}{2}0$ .
- (f)  $00u$ ;  $\frac{1}{2}\frac{1}{2}u$ ;  $\frac{1}{2}, \frac{1}{2}, u+\frac{1}{2}$ ;  $0, 0, u+\frac{1}{2}$ ;  
 $00\bar{u}$ ;  $\frac{1}{2}\frac{1}{2}\bar{u}$ ;  $\frac{1}{2}, \frac{1}{2}, \frac{1}{2}-u$ ;  $0, 0, \frac{1}{2}-u$ .
- (g)  $0\frac{1}{2}u$ ;  $\frac{1}{2}0u$ ;  $\frac{1}{2}, 0, u+\frac{1}{2}$ ;  $0, \frac{1}{2}, u+\frac{1}{2}$ ;  
 $0\frac{1}{2}\bar{u}$ ;  $\frac{1}{2}0\bar{u}$ ;  $\frac{1}{2}, 0, \frac{1}{2}-u$ ;  $0, \frac{1}{2}, \frac{1}{2}-u$ .
- (h)  $u00$ ;  $0u\frac{1}{2}$ ;  $\frac{1}{2}, u+\frac{1}{2}, \frac{1}{2}$ ;  $u+\frac{1}{2}, \frac{1}{2}, 0$ ;  
 $\bar{u}00$ ;  $0\bar{u}\frac{1}{2}$ ;  $\frac{1}{2}, \frac{1}{2}-u, \frac{1}{2}$ ;  $\frac{1}{2}-u, \frac{1}{2}, 0$ .
- (i)  $u\frac{1}{2}\frac{1}{2}$ ;  $\frac{1}{2}u0$ ;  $0, u+\frac{1}{2}, 0$ ;  $u+\frac{1}{2}, 0, \frac{1}{2}$ ;  
 $\bar{u}\frac{1}{2}\frac{1}{2}$ ;  $\frac{1}{2}\bar{u}0$ ;  $0, \frac{1}{2}-u, 0$ ;  $\frac{1}{2}-u, 0, \frac{1}{2}$ .
- (j)  $uu\frac{1}{2}$ ;  $u\bar{u}\frac{1}{2}$ ;  $u+\frac{1}{2}, u+\frac{1}{2}, \frac{1}{2}$ ;  $u+\frac{1}{2}, \frac{1}{2}-u, \frac{1}{2}$ ;  
 $\bar{u}\bar{u}\frac{1}{2}$ ;  $\bar{u}u\frac{1}{2}$ ;  $\frac{1}{2}-u, \frac{1}{2}-u, \frac{1}{2}$ ;  $\frac{1}{2}-u, u+\frac{1}{2}, \frac{1}{2}$ .

Sixteen equivalent positions:

- (k)  $xyz$ ;  $y, \bar{x}, z+\frac{1}{2}$ ;  $\bar{x}\bar{y}z$ ;  $\bar{y}, x, z+\frac{1}{2}$ ;  
 $x+\frac{1}{2}, y+\frac{1}{2}, \bar{z}$ ;  $y+\frac{1}{2}, \frac{1}{2}-x, \frac{1}{2}-z$ ;  $\frac{1}{2}-x, \frac{1}{2}-y, \bar{z}$ ;  
 $\frac{1}{2}-y, x+\frac{1}{2}, \frac{1}{2}-z$ ;  
 $\frac{1}{2}-x, y+\frac{1}{2}, z$ ;  $\frac{1}{2}-y, \frac{1}{2}-x, z+\frac{1}{2}$ ;  $x+\frac{1}{2}, \frac{1}{2}-y, z$ ;  
 $y+\frac{1}{2}, x+\frac{1}{2}, z+\frac{1}{2}$ ;  
 $\bar{x}\bar{y}\bar{z}$ ;  $\bar{y}, \bar{x}, \frac{1}{2}-z$ ;  $x\bar{y}\bar{z}$ ;  $y, x, \frac{1}{2}-z$ .

SPACE-GROUP  $D_{4h}^{12}$ \*This group is  $D_{4h}^{11}$  of the previous definitions.

Two equivalent positions:

- (a)  $000$ ;  $\frac{1}{2}\frac{1}{2}\frac{1}{2}$ . (b)  $00\frac{1}{2}$ ;  $\frac{1}{2}\frac{1}{2}0$ .

Four equivalent positions:

- (c)  $0\frac{1}{2}0$ ;  $0\frac{1}{2}\frac{1}{2}$ ;  $\frac{1}{2}0\frac{1}{2}$ ;  $\frac{1}{2}00$ .  
(d)  $0\frac{1}{2}\frac{1}{2}$ ;  $0\frac{1}{2}\frac{2}{2}$ ;  $\frac{1}{2}0\frac{2}{2}$ ;  $\frac{1}{2}0\frac{1}{2}$ .  
(e)  $\frac{1}{2}\frac{1}{2}\frac{1}{2}$ ;  $\frac{2}{2}\frac{1}{2}\frac{1}{2}$ ;  $\frac{2}{2}\frac{2}{2}\frac{1}{2}$ ;  $\frac{1}{2}\frac{2}{2}\frac{2}{2}$ .  
(f)  $\frac{2}{2}\frac{2}{2}\frac{2}{2}$ ;  $\frac{1}{2}\frac{2}{2}\frac{1}{2}$ ;  $\frac{1}{2}\frac{1}{2}\frac{2}{2}$ ;  $\frac{2}{2}\frac{1}{2}\frac{2}{2}$ .  
(g)  $00u$ ;  $00\bar{u}$ ;  $\frac{1}{2}, \frac{1}{2}, u+\frac{1}{2}$ ;  $\frac{1}{2}, \frac{1}{2}, \frac{1}{2}-u$ .

Eight equivalent positions:

- (h)  $0\frac{1}{2}u$ ;  $\frac{1}{2}0u$ ;  $\frac{1}{2}, 0, u+\frac{1}{2}$ ;  $0, \frac{1}{2}, u+\frac{1}{2}$ ;  
 $0\frac{1}{2}\bar{u}$ ;  $\frac{1}{2}0\bar{u}$ ;  $\frac{1}{2}, 0, \frac{1}{2}-u$ ;  $0, \frac{1}{2}, \frac{1}{2}-u$ .
- (i)  $u00$ ;  $0u0$ ;  $\frac{1}{2}, u+\frac{1}{2}, \frac{1}{2}$ ;  $u+\frac{1}{2}, \frac{1}{2}, \frac{1}{2}$ ;  
 $\bar{u}00$ ;  $0\bar{u}0$ ;  $\frac{1}{2}, \frac{1}{2}-u, \frac{1}{2}$ ;  $\frac{1}{2}-u, \frac{1}{2}, \frac{1}{2}$ .
- (j)  $u0\frac{1}{2}$ ;  $0u\frac{1}{2}$ ;  $\frac{1}{2}, u+\frac{1}{2}, 0$ ;  $u+\frac{1}{2}, \frac{1}{2}, 0$ ;  
 $\bar{u}0\frac{1}{2}$ ;  $0\bar{u}\frac{1}{2}$ ;  $\frac{1}{2}, \frac{1}{2}-u, 0$ ;  $\frac{1}{2}-u, \frac{1}{2}, 0$ .
- (k)  $u, u+\frac{1}{2}, \frac{1}{2}$ ;  $u, \frac{1}{2}-u, \frac{2}{2}$ ;  $\bar{u}, \frac{1}{2}-u, \frac{1}{2}$ ;  $\bar{u}, u+\frac{1}{2}, \frac{2}{2}$ ;  
 $u+\frac{1}{2}, u, \frac{1}{2}$ ;  $u+\frac{1}{2}, \bar{u}, \frac{2}{2}$ ;  $\frac{1}{2}-u, \bar{u}, \frac{1}{2}$ ;  $\frac{1}{2}-u, u, \frac{2}{2}$ .
- (l)  $u, u+\frac{1}{2}, \frac{2}{2}$ ;  $u, \frac{1}{2}-u, \frac{1}{2}$ ;  $\bar{u}, \frac{1}{2}-u, \frac{2}{2}$ ;  $\bar{u}, u+\frac{1}{2}, \frac{1}{2}$ ;  
 $u+\frac{1}{2}, u, \frac{2}{2}$ ;  $u+\frac{1}{2}, \bar{u}, \frac{1}{2}$ ;  $\frac{1}{2}-u, \bar{u}, \frac{2}{2}$ ;  $\frac{1}{2}-u, u, \frac{1}{2}$ .
- (m)  $uu\bar{v}$ ;  $u+\frac{1}{2}, \frac{1}{2}-u, v+\frac{1}{2}$ ;  $\bar{u}\bar{u}\bar{v}$ ;  $\frac{1}{2}-u, u+\frac{1}{2}, v+\frac{1}{2}$ ;  
 $u\bar{u}\bar{v}$ ;  $u+\frac{1}{2}, u+\frac{1}{2}, \frac{1}{2}-v$ ;  $\bar{u}u\bar{v}$ ;  $\frac{1}{2}-u, \frac{1}{2}-u, \frac{1}{2}-v$ .

SPACE-GROUP  $D_{4h}^{12}$  (continued).

Sixteen equivalent positions:

- (n)  $xyz$ ;  $y+\frac{1}{2}, \frac{1}{2}-x, z+\frac{1}{2}$ ;  $\bar{x}\bar{y}z$ ;  $\frac{1}{2}-y, x+\frac{1}{2}, z+\frac{1}{2}$ ;  
 $x+\frac{1}{2}, y+\frac{1}{2}, \frac{1}{2}-z$ ;  $y\bar{x}\bar{z}$ ;  $\frac{1}{2}-x, \frac{1}{2}-y, \frac{1}{2}-z$ ;  $\bar{y}\bar{x}\bar{z}$ ;  
 $\frac{1}{2}-x, y+\frac{1}{2}, z+\frac{1}{2}$ ;  $\bar{y}\bar{x}z$ ;  $x+\frac{1}{2}, \frac{1}{2}-y, z+\frac{1}{2}$ ;  $yxz$ ;  
 $\bar{x}y\bar{z}$ ;  $\frac{1}{2}-y, \frac{1}{2}-x, \frac{1}{2}-z$ ;  $x\bar{y}\bar{z}$ ;  $y+\frac{1}{2}, x+\frac{1}{2}, \frac{1}{2}-z$ .

SPACE-GROUP  $D_{4h}^{13}$ .\*

Space-groups  $D_{4h}^{12}$  and  $D_{4h}^{14}$  also are interchanged.

Four equivalent positions:

- (a)  $000$ ;  $00\frac{1}{2}$ ;  $\frac{1}{2}\frac{1}{2}0$ ;  $\frac{1}{2}\frac{1}{2}\frac{1}{2}$ .  
 (b)  $00\frac{1}{2}$ ;  $00\frac{1}{2}$ ;  $\frac{1}{2}\frac{1}{2}\frac{1}{2}$ ;  $\frac{1}{2}\frac{1}{2}\frac{1}{2}$ .  
 (c)  $0\frac{1}{2}0$ ;  $\frac{1}{2}0\frac{1}{2}$ ;  $\frac{1}{2}00$ ;  $0\frac{1}{2}\frac{1}{2}$ .  
 (d)  $0\frac{1}{2}\frac{1}{2}$ ;  $\frac{1}{2}0\frac{1}{2}$ ;  $0\frac{1}{2}\frac{1}{2}$ ;  $\frac{1}{2}0\frac{1}{2}$ .

Eight equivalent positions:

- (e)  $00u$ ;  $\frac{1}{2}\frac{1}{2}u$ ;  $\frac{1}{2}, \frac{1}{2}, u+\frac{1}{2}$ ;  $0, 0, u+\frac{1}{2}$ ;  
 $00\bar{u}$ ;  $\frac{1}{2}\frac{1}{2}\bar{u}$ ;  $\frac{1}{2}, \frac{1}{2}, \frac{1}{2}-u$ ;  $0, 0, \frac{1}{2}-u$ .  
 (f)  $0\frac{1}{2}u$ ;  $\frac{1}{2}0u$ ;  $\frac{1}{2}, 0, u+\frac{1}{2}$ ;  $0, \frac{1}{2}, u+\frac{1}{2}$ ;  
 $0\frac{1}{2}\bar{u}$ ;  $\frac{1}{2}0\bar{u}$ ;  $\frac{1}{2}, 0, \frac{1}{2}-u$ ;  $0, \frac{1}{2}, \frac{1}{2}-u$ .  
 (g)  $u, u+\frac{1}{2}, \frac{1}{2}$ ;  $u+\frac{1}{2}, \bar{u}, \frac{1}{2}$ ;  $\bar{u}, \frac{1}{2}-u, \frac{1}{2}$ ;  $\frac{1}{2}-u, u, \frac{1}{2}$ ;  
 $u, u+\frac{1}{2}, \frac{1}{2}$ ;  $u+\frac{1}{2}, \bar{u}, \frac{1}{2}$ ;  $\bar{u}, \frac{1}{2}-u, \frac{1}{2}$ ;  $\frac{1}{2}-u, u, \frac{1}{2}$ .  
 (h)  $uv0$ ;  $\bar{u}\bar{v}0$ ;  $\frac{1}{2}-u, v+\frac{1}{2}, 0$ ;  $u+\frac{1}{2}, \frac{1}{2}-v, 0$ ;  
 $v\bar{u}\frac{1}{2}$ ;  $\bar{v}u\frac{1}{2}$ ;  $\frac{1}{2}-v, \frac{1}{2}-u, \frac{1}{2}$ ;  $v+\frac{1}{2}, u+\frac{1}{2}, \frac{1}{2}$ .

Sixteen equivalent positions:

- (i)  $xyz$ ;  $y, \bar{x}, z+\frac{1}{2}$ ;  $\bar{x}\bar{y}z$ ;  $\bar{y}, x, z+\frac{1}{2}$ ;  
 $xy\bar{z}$ ;  $y, \bar{x}, \frac{1}{2}-z$ ;  $\bar{x}\bar{y}\bar{z}$ ;  $\bar{y}, x, \frac{1}{2}-z$ ;  
 $\frac{1}{2}-x, y+\frac{1}{2}, z$ ;  $\frac{1}{2}-y, \frac{1}{2}-x, z+\frac{1}{2}$ ;  $x+\frac{1}{2}, \frac{1}{2}-y, z$ ;  
 $y+\frac{1}{2}, x+\frac{1}{2}, z+\frac{1}{2}$ ;  
 $\frac{1}{2}-x, y+\frac{1}{2}, \bar{z}$ ;  $\frac{1}{2}-y, \frac{1}{2}-x, \frac{1}{2}-z$ ;  $x+\frac{1}{2}, \frac{1}{2}-y, \bar{z}$ ;  
 $y+\frac{1}{2}, x+\frac{1}{2}, \frac{1}{2}-z$ .

SPACE-GROUP  $D_{4h}^{14}$ .\*

Two equivalent positions:

- (a)  $000$ ;  $\frac{1}{2}\frac{1}{2}\frac{1}{2}$ . (b)  $00\frac{1}{2}$ ;  $\frac{1}{2}\frac{1}{2}0$ .

Four equivalent positions:

- (c)  $0\frac{1}{2}0$ ;  $0\frac{1}{2}\frac{1}{2}$ ;  $\frac{1}{2}0\frac{1}{2}$ ;  $\frac{1}{2}00$ .  
 (d)  $0\frac{1}{2}\frac{1}{2}$ ;  $0\frac{1}{2}\frac{1}{2}$ ;  $\frac{1}{2}0\frac{1}{2}$ ;  $\frac{1}{2}0\frac{1}{2}$ .  
 (e)  $00u$ ;  $00\bar{u}$ ;  $\frac{1}{2}, \frac{1}{2}, u+\frac{1}{2}$ ;  $\frac{1}{2}, \frac{1}{2}, \frac{1}{2}-u$ .  
 (f)  $uu0$ ;  $\bar{u}\bar{u}0$ ;  $\frac{1}{2}-u, u+\frac{1}{2}, \frac{1}{2}$ ;  $u+\frac{1}{2}, \frac{1}{2}-u, \frac{1}{2}$ .  
 (g)  $uu\frac{1}{2}$ ;  $\bar{u}\bar{u}\frac{1}{2}$ ;  $\frac{1}{2}-u, u+\frac{1}{2}, 0$ ;  $u+\frac{1}{2}, \frac{1}{2}-u, 0$ .

Eight equivalent positions:

- (h)  $0\frac{1}{2}u$ ;  $\frac{1}{2}0u$ ;  $\frac{1}{2}, 0, u+\frac{1}{2}$ ;  $0, \frac{1}{2}, u+\frac{1}{2}$ ;  
 $0\frac{1}{2}\bar{u}$ ;  $\frac{1}{2}0\bar{u}$ ;  $\frac{1}{2}, 0, \frac{1}{2}-u$ ;  $0, \frac{1}{2}, \frac{1}{2}-u$ .  
 (i)  $uv0$ ;  $v\bar{u}0$ ;  $v+\frac{1}{2}, \frac{1}{2}-u, \frac{1}{2}$ ;  $u+\frac{1}{2}, \frac{1}{2}-v, \frac{1}{2}$ ;  
 $\bar{u}\bar{v}0$ ;  $\bar{v}\bar{u}0$ ;  $\frac{1}{2}-v, u+\frac{1}{2}, \frac{1}{2}$ ;  $\frac{1}{2}-u, v+\frac{1}{2}, \frac{1}{2}$ .  
 (j)  $uu\bar{v}$ ;  $u\bar{u}\bar{v}$ ;  $u+\frac{1}{2}, \frac{1}{2}-u, \frac{1}{2}-v$ ;  $u+\frac{1}{2}, \frac{1}{2}-u, v+\frac{1}{2}$ ;  
 $\bar{u}\bar{u}\bar{v}$ ;  $\bar{u}\bar{u}\bar{v}$ ;  $\frac{1}{2}-u, u+\frac{1}{2}, v+\frac{1}{2}$ ;  $\frac{1}{2}-u, u+\frac{1}{2}, \frac{1}{2}-v$ .

SPACE-GROUP  $D_{2d}^{14}$  (continued).

Sixteen equivalent positions:

$$(k) \begin{aligned} &xyz; y+\frac{1}{2}, \frac{1}{2}-x, z+\frac{1}{2}; \bar{x}\bar{y}z; \frac{1}{2}-y, x+\frac{1}{2}, z+\frac{1}{2}; \\ &xy\bar{z}; y+\frac{1}{2}, \frac{1}{2}-x, \frac{1}{2}-z; \bar{x}\bar{y}\bar{z}; \frac{1}{2}-y, x+\frac{1}{2}, \frac{1}{2}-z; \\ &\frac{1}{2}-x, y+\frac{1}{2}, z+\frac{1}{2}; \bar{y}\bar{x}z; x+\frac{1}{2}, \frac{1}{2}-y, z+\frac{1}{2}; yxz; \\ &\frac{1}{2}-x, y+\frac{1}{2}, \frac{1}{2}-z; \bar{y}\bar{x}\bar{z}; x+\frac{1}{2}, \frac{1}{2}-y, \frac{1}{2}-z; yx\bar{z}. \end{aligned}$$

SPACE-GROUP  $D_{2d}^{15}$ .\*Space-groups  $D_{2d}^{15}$  and  $D_{2d}^{16}$  are here interchanged.

Two equivalent positions:

$$(a) 000; \frac{1}{2}\frac{1}{2}\frac{1}{2}. \quad (b) 00\frac{1}{2}; \frac{1}{2}\frac{1}{2}0.$$

Four equivalent positions:

$$(c) 00u; 00\bar{u}; \frac{1}{2}, \frac{1}{2}, \frac{1}{2}-u; \frac{1}{2}, \frac{1}{2}, u+\frac{1}{2}. \\ (d) 0\frac{1}{2}u; \frac{1}{2}0\bar{u}; \frac{1}{2}, 0, \frac{1}{2}-u; 0, \frac{1}{2}, u+\frac{1}{2}.$$

Eight equivalent positions:

$$(e) \begin{aligned} &\frac{1}{2}\frac{1}{2}\frac{1}{2}; \frac{1}{2}\frac{1}{2}\frac{1}{2}; \frac{1}{2}\frac{1}{2}\frac{1}{2}; \frac{1}{2}\frac{1}{2}\frac{1}{2}; \\ &\frac{1}{2}\frac{1}{2}\frac{1}{2}; \frac{1}{2}\frac{1}{2}\frac{1}{2}; \frac{1}{2}\frac{1}{2}\frac{1}{2}; \frac{1}{2}\frac{1}{2}\frac{1}{2}. \end{aligned} \\ (f) \begin{aligned} &uu0; \bar{u}\bar{u}0; u+\frac{1}{2}, \frac{1}{2}-u, \frac{1}{2}; \frac{1}{2}-u, u+\frac{1}{2}, \frac{1}{2}; \\ &u\bar{u}0; \bar{u}u0; u+\frac{1}{2}, u+\frac{1}{2}, \frac{1}{2}; \frac{1}{2}-u, \frac{1}{2}-u, \frac{1}{2}. \end{aligned} \\ (g) \begin{aligned} &0uv; 0\bar{u}\bar{v}; u+\frac{1}{2}, \frac{1}{2}, v+\frac{1}{2}; \frac{1}{2}-u, \frac{1}{2}, v+\frac{1}{2}; \\ &u0\bar{v}; \bar{u}0\bar{v}; \frac{1}{2}, u+\frac{1}{2}, \frac{1}{2}-v; \frac{1}{2}, \frac{1}{2}-u, \frac{1}{2}-v. \end{aligned}$$

Sixteen equivalent positions:

$$(h) \begin{aligned} &xyz; y+\frac{1}{2}, \frac{1}{2}-x, z+\frac{1}{2}; \bar{x}\bar{y}z; \frac{1}{2}-y, x+\frac{1}{2}, z+\frac{1}{2}; \\ &x+\frac{1}{2}, y+\frac{1}{2}, \frac{1}{2}-z; y\bar{x}\bar{z}; \frac{1}{2}-x, \frac{1}{2}-y, \frac{1}{2}-z; \bar{y}\bar{x}\bar{z}; \\ &\bar{x}yz; \frac{1}{2}-y, \frac{1}{2}-x, z+\frac{1}{2}; x\bar{y}z; y+\frac{1}{2}, x+\frac{1}{2}, z+\frac{1}{2}; \\ &\frac{1}{2}-x, y+\frac{1}{2}, \frac{1}{2}-z; \bar{y}\bar{x}\bar{z}; x+\frac{1}{2}, \frac{1}{2}-y, \frac{1}{2}-z; yx\bar{z}. \end{aligned}$$

SPACE-GROUP  $D_{2d}^{16}$ .\*

Four equivalent positions:

$$(a) 000; \frac{1}{2}\frac{1}{2}\frac{1}{2}; 00\frac{1}{2}; \frac{1}{2}\frac{1}{2}0. \\ (b) 00\frac{1}{2}; \frac{1}{2}\frac{1}{2}\frac{1}{2}; 00\frac{1}{2}; \frac{1}{2}\frac{1}{2}\frac{1}{2}. \\ (c) \frac{1}{2}\frac{1}{2}0; \frac{1}{2}\frac{1}{2}\frac{1}{2}; \frac{1}{2}\frac{1}{2}0; \frac{1}{2}\frac{1}{2}\frac{1}{2}. \\ (d) \frac{1}{2}\frac{1}{2}\frac{1}{2}; \frac{1}{2}\frac{1}{2}0; \frac{1}{2}\frac{1}{2}\frac{1}{2}; \frac{1}{2}\frac{1}{2}0. \\ (e) 0\frac{1}{2}u; \frac{1}{2}0\bar{u}; \frac{1}{2}, 0, \frac{1}{2}-u; 0, \frac{1}{2}, u+\frac{1}{2}.$$

Eight equivalent positions:

$$(f) \begin{aligned} &00u; \frac{1}{2}\frac{1}{2}u; \frac{1}{2}, \frac{1}{2}, u+\frac{1}{2}; 0, 0, u+\frac{1}{2}; \\ &00\bar{u}; \frac{1}{2}\frac{1}{2}\bar{u}; \frac{1}{2}, \frac{1}{2}, \frac{1}{2}-u; 0, 0, \frac{1}{2}-u. \end{aligned} \\ (g) \begin{aligned} &uu0; u\bar{u}\frac{1}{2}; u+\frac{1}{2}, \frac{1}{2}-u, \frac{1}{2}; u+\frac{1}{2}, u+\frac{1}{2}, 0; \\ &\bar{u}\bar{u}0; \bar{u}u\frac{1}{2}; \frac{1}{2}-u, u+\frac{1}{2}, \frac{1}{2}; \frac{1}{2}-u, \frac{1}{2}-u, 0. \end{aligned} \\ (h) \begin{aligned} &uu\frac{1}{2}; u\bar{u}0; u+\frac{1}{2}, \frac{1}{2}-u, 0; u+\frac{1}{2}, u+\frac{1}{2}, \frac{1}{2}; \\ &\bar{u}\bar{u}\frac{1}{2}; \bar{u}u0; \frac{1}{2}-u, u+\frac{1}{2}, 0; \frac{1}{2}-u, \frac{1}{2}-u, \frac{1}{2}. \end{aligned} \\ (i) \begin{aligned} &u, u+\frac{1}{2}, v; u, \frac{1}{2}-u, v+\frac{1}{2}; \bar{u}, \frac{1}{2}-u, v; \bar{u}, u+\frac{1}{2}, v+\frac{1}{2}; \\ &u+\frac{1}{2}, u, \bar{v}; u+\frac{1}{2}, \bar{u}, \frac{1}{2}-v; \frac{1}{2}-u, \bar{u}, \bar{v}; \frac{1}{2}-u, u, \frac{1}{2}-v. \end{aligned}$$

SPACE-GROUP  $D_{2d}^{16}$ -(continued).

Sixteen equivalent positions:

- (j)  $xyz$ ;  $y+\frac{1}{2}$ ,  $\frac{1}{2}-x$ ,  $z+\frac{1}{2}$ ;  $\bar{x}\bar{y}z$ ;  $\frac{1}{2}-y$ ,  $x+\frac{1}{2}$ ,  $z+\frac{1}{2}$ ;  
 $x+\frac{1}{2}$ ,  $y+\frac{1}{2}$ ,  $\bar{z}$ ;  $y$ ,  $\bar{x}$ ,  $\frac{1}{2}-z$ ;  $\frac{1}{2}-x$ ,  $\frac{1}{2}-y$ ,  $\bar{z}$ ;  $\bar{y}$ ,  $x$ ,  $\frac{1}{2}-z$ ;  
 $\bar{x}$ ,  $y$ ,  $z+\frac{1}{2}$ ;  $\frac{1}{2}-y$ ,  $\frac{1}{2}-x$ ,  $z$ ;  $x$ ,  $\bar{y}$ ,  $z+\frac{1}{2}$ ;  $y+\frac{1}{2}$ ,  $x+\frac{1}{2}$ ,  $z$ ;  
 $\frac{1}{2}-x$ ,  $y+\frac{1}{2}$ ,  $\frac{1}{2}-z$ ;  $\bar{y}\bar{x}\bar{z}$ ;  $x+\frac{1}{2}$ ,  $\frac{1}{2}-y$ ,  $\frac{1}{2}-z$ ;  $yx\bar{z}$ ;

SPACE-GROUP  $D_{2d}^{17}$ .

Two equivalent positions:

- (a)  $000$ ;  $\frac{1}{2}\frac{1}{2}\frac{1}{2}$ . (b)  $00\frac{1}{2}$ ;  $\frac{1}{2}\frac{1}{2}0$ .

Four equivalent positions:

- (c)  $0\frac{1}{2}0$ ;  $\frac{1}{2}00$ ;  $\frac{1}{2}0\frac{1}{2}$ ;  $0\frac{1}{2}\frac{1}{2}$ .  
 (d)  $0\frac{1}{2}\frac{1}{2}$ ;  $\frac{1}{2}0\frac{1}{2}$ ;  $0\frac{1}{2}\frac{1}{2}$ ;  $\frac{1}{2}0\frac{1}{2}$ .  
 (e)  $00u$ ;  $00\bar{u}$ ;  $\frac{1}{2}$ ,  $\frac{1}{2}$ ,  $\frac{1}{2}-u$ ;  $\frac{1}{2}$ ,  $\frac{1}{2}$ ,  $u+\frac{1}{2}$ .

Eight equivalent positions:

- (f)  $\frac{1}{2}\frac{1}{2}\frac{1}{2}$ ;  $\frac{1}{2}\frac{1}{2}\frac{1}{2}$ ;  $\frac{1}{2}\frac{1}{2}\frac{1}{2}$ ;  $\frac{1}{2}\frac{1}{2}\frac{1}{2}$ ;  
 $\frac{1}{2}\frac{1}{2}\frac{1}{2}$ ;  $\frac{1}{2}\frac{1}{2}\frac{1}{2}$ ;  $\frac{1}{2}\frac{1}{2}\frac{1}{2}$ ;  $\frac{1}{2}\frac{1}{2}\frac{1}{2}$ .  
 (g)  $0\frac{1}{2}u$ ;  $\frac{1}{2}0u$ ;  $\frac{1}{2}$ ,  $0$ ,  $u+\frac{1}{2}$ ;  $0$ ,  $\frac{1}{2}$ ,  $u+\frac{1}{2}$ ;  
 $0\frac{1}{2}\bar{u}$ ;  $\frac{1}{2}0\bar{u}$ ;  $\frac{1}{2}$ ,  $0$ ,  $\frac{1}{2}-u$ ;  $0$ ,  $\frac{1}{2}$ ,  $\frac{1}{2}-u$ .  
 (h)  $uu0$ ;  $u\bar{u}0$ ;  $u+\frac{1}{2}$ ,  $\frac{1}{2}-u$ ,  $\frac{1}{2}$ ;  $u+\frac{1}{2}$ ,  $u+\frac{1}{2}$ ,  $\frac{1}{2}$ ;  
 $\bar{u}\bar{u}0$ ;  $\bar{u}u0$ ;  $\frac{1}{2}-u$ ,  $u+\frac{1}{2}$ ,  $\frac{1}{2}$ ;  $\frac{1}{2}-u$ ,  $\frac{1}{2}-u$ ,  $\frac{1}{2}$ .  
 (i)  $u00$ ;  $0u0$ ;  $\frac{1}{2}$ ,  $u+\frac{1}{2}$ ,  $\frac{1}{2}$ ;  $u+\frac{1}{2}$ ,  $\frac{1}{2}$ ,  $\frac{1}{2}$ ;  
 $\bar{u}00$ ;  $0\bar{u}0$ ;  $\frac{1}{2}$ ,  $\frac{1}{2}-u$ ,  $\frac{1}{2}$ ;  $\frac{1}{2}-u$ ,  $\frac{1}{2}$ ,  $\frac{1}{2}$ .  
 (j)  $u0\frac{1}{2}$ ;  $0u\frac{1}{2}$ ;  $\frac{1}{2}$ ,  $u+\frac{1}{2}$ ,  $0$ ;  $u+\frac{1}{2}$ ,  $\frac{1}{2}$ ,  $0$ ;  
 $\bar{u}0\frac{1}{2}$ ;  $0\bar{u}\frac{1}{2}$ ;  $\frac{1}{2}$ ,  $\frac{1}{2}-u$ ,  $0$ ;  $\frac{1}{2}-u$ ,  $\frac{1}{2}$ ,  $0$ .

Sixteen equivalent positions:

- (k)  $u$ ,  $u+\frac{1}{2}$ ,  $\frac{1}{2}$ ;  $\frac{1}{2}-u$ ,  $u$ ,  $\frac{1}{2}$ ;  $\bar{u}$ ,  $\frac{1}{2}-u$ ,  $\frac{1}{2}$ ;  $u+\frac{1}{2}$ ,  $\bar{u}$ ,  $\frac{1}{2}$ ;  
 $u+\frac{1}{2}$ ,  $u$ ,  $\frac{1}{2}$ ;  $u$ ,  $\frac{1}{2}-u$ ,  $\frac{1}{2}$ ;  $\frac{1}{2}-u$ ,  $\bar{u}$ ,  $\frac{1}{2}$ ;  $\bar{u}$ ,  $u+\frac{1}{2}$ ,  $\frac{1}{2}$ ;  
 $\bar{u}$ ,  $\frac{1}{2}-u$ ,  $\frac{1}{2}$ ;  $u+\frac{1}{2}$ ,  $\bar{u}$ ,  $\frac{1}{2}$ ;  $u$ ,  $u+\frac{1}{2}$ ,  $\frac{1}{2}$ ;  $\frac{1}{2}-u$ ,  $u$ ,  $\frac{1}{2}$ ;  
 $\frac{1}{2}-u$ ,  $\bar{u}$ ,  $\frac{1}{2}$ ;  $\bar{u}$ ,  $u+\frac{1}{2}$ ,  $\frac{1}{2}$ ;  $u+\frac{1}{2}$ ,  $u$ ,  $\frac{1}{2}$ ;  $u$ ,  $\frac{1}{2}-u$ ,  $\frac{1}{2}$ .  
 (l)  $uv0$ ;  $\bar{v}u0$ ;  $\bar{u}\bar{v}0$ ;  $v\bar{u}0$ ;  
 $v\bar{u}0$ ;  $u\bar{v}0$ ;  $\bar{v}\bar{u}0$ ;  $\bar{u}v0$ ;  
 $u+\frac{1}{2}$ ,  $v+\frac{1}{2}$ ,  $\frac{1}{2}$ ;  $\frac{1}{2}-v$ ,  $u+\frac{1}{2}$ ,  $\frac{1}{2}$ ;  $\frac{1}{2}-u$ ,  $\frac{1}{2}-v$ ,  $\frac{1}{2}$ ;  $v+\frac{1}{2}$ ,  $\frac{1}{2}-u$ ,  $\frac{1}{2}$ ;  
 $v+\frac{1}{2}$ ,  $u+\frac{1}{2}$ ,  $\frac{1}{2}$ ;  $u+\frac{1}{2}$ ,  $\frac{1}{2}-v$ ,  $\frac{1}{2}$ ;  $\frac{1}{2}-v$ ,  $\frac{1}{2}-u$ ,  $\frac{1}{2}$ ;  $\frac{1}{2}-u$ ,  $v+\frac{1}{2}$ ,  $\frac{1}{2}$ .  
 (m)  $u\bar{u}v$ ;  $uuv$ ;  $\bar{u}u\bar{v}$ ;  $\bar{u}\bar{u}v$ ;  
 $\bar{u}u\bar{v}$ ;  $u\bar{u}\bar{v}$ ;  $u\bar{u}\bar{v}$ ;  $\bar{u}\bar{u}\bar{v}$ ;  
 $u+\frac{1}{2}$ ,  $\frac{1}{2}-u$ ,  $v+\frac{1}{2}$ ;  $u+\frac{1}{2}$ ,  $u+\frac{1}{2}$ ,  $v+\frac{1}{2}$ ;  $\frac{1}{2}-u$ ,  $u+\frac{1}{2}$ ,  $v+\frac{1}{2}$ ;  
 $\frac{1}{2}-u$ ,  $\frac{1}{2}-u$ ,  $v+\frac{1}{2}$ ;  
 $\frac{1}{2}-u$ ,  $u+\frac{1}{2}$ ,  $\frac{1}{2}-v$ ;  $u+\frac{1}{2}$ ,  $u+\frac{1}{2}$ ,  $\frac{1}{2}-v$ ;  $u+\frac{1}{2}$ ,  $\frac{1}{2}-u$ ,  $\frac{1}{2}-v$ ;  
 $\frac{1}{2}-u$ ,  $\frac{1}{2}-u$ ,  $\frac{1}{2}-v$ .  
 (n)  $0uv$ ;  $\bar{u}0v$ ;  $0\bar{u}v$ ;  $u0v$ ;  
 $u0\bar{v}$ ;  $0\bar{u}\bar{v}$ ;  $\bar{u}0\bar{v}$ ;  $0u\bar{v}$ ;  
 $\frac{1}{2}$ ,  $u+\frac{1}{2}$ ,  $v+\frac{1}{2}$ ;  $\frac{1}{2}-u$ ,  $\frac{1}{2}$ ,  $v+\frac{1}{2}$ ;  $\frac{1}{2}$ ,  $\frac{1}{2}-u$ ,  $v+\frac{1}{2}$ ;  $u+\frac{1}{2}$ ,  $\frac{1}{2}$ ,  $v+\frac{1}{2}$ ;  
 $u+\frac{1}{2}$ ,  $\frac{1}{2}$ ,  $\frac{1}{2}-v$ ;  $\frac{1}{2}$ ,  $\frac{1}{2}-u$ ,  $\frac{1}{2}-v$ ;  $\frac{1}{2}-u$ ,  $\frac{1}{2}$ ,  $\frac{1}{2}-v$ ;  $\frac{1}{2}$ ,  $u+\frac{1}{2}$ ,  $\frac{1}{2}-v$ .



SPACE-GROUP  $D_{2h}^{17}$ -(continued).

Thirty-two equivalent positions:

- (o)  $xyz$ ;  $\bar{y}xz$ ;  $\bar{x}\bar{y}z$ ;  $y\bar{x}z$ ;  
 $yx\bar{z}$ ;  $x\bar{y}\bar{z}$ ;  $\bar{y}\bar{x}\bar{z}$ ;  $\bar{x}y\bar{z}$ ;  
 $\bar{x}\bar{y}\bar{z}$ ;  $y\bar{x}\bar{z}$ ;  $xy\bar{z}$ ;  $\bar{y}x\bar{z}$ ;  
 $\bar{y}\bar{x}z$ ;  $\bar{x}yz$ ;  $yxz$ ;  $x\bar{y}z$ ;  
 $x+\frac{1}{2}$ ,  $y+\frac{1}{2}$ ,  $z+\frac{1}{2}$ ;  $\frac{1}{2}-y$ ,  $x+\frac{1}{2}$ ,  $z+\frac{1}{2}$ ;  $\frac{1}{2}-x$ ,  $\frac{1}{2}-y$ ,  $z+\frac{1}{2}$ ;  
 $y+\frac{1}{2}$ ,  $\frac{1}{2}-x$ ,  $z+\frac{1}{2}$ ;  
 $y+\frac{1}{2}$ ,  $x+\frac{1}{2}$ ,  $\frac{1}{2}-z$ ;  $x+\frac{1}{2}$ ,  $\frac{1}{2}-y$ ,  $\frac{1}{2}-z$ ;  $\frac{1}{2}-y$ ,  $\frac{1}{2}-x$ ,  $\frac{1}{2}-z$ ;  
 $\frac{1}{2}-x$ ,  $y+\frac{1}{2}$ ,  $\frac{1}{2}-z$ ;  
 $\frac{1}{2}-x$ ,  $\frac{1}{2}-y$ ,  $\frac{1}{2}-z$ ;  $y+\frac{1}{2}$ ,  $\frac{1}{2}-x$ ,  $\frac{1}{2}-z$ ;  $x+\frac{1}{2}$ ,  $y+\frac{1}{2}$ ,  $\frac{1}{2}-z$ ;  
 $\frac{1}{2}-y$ ,  $x+\frac{1}{2}$ ,  $\frac{1}{2}-z$ ;  
 $\frac{1}{2}-y$ ,  $\frac{1}{2}-x$ ,  $z+\frac{1}{2}$ ;  $\frac{1}{2}-x$ ,  $y+\frac{1}{2}$ ,  $z+\frac{1}{2}$ ;  $y+\frac{1}{2}$ ,  $x+\frac{1}{2}$ ,  $z+\frac{1}{2}$ ;  
 $x+\frac{1}{2}$ ,  $\frac{1}{2}-y$ ,  $z+\frac{1}{2}$ .

SPACE-GROUP  $D_{2h}^{18}$ .

Four equivalent positions:

- (a)  $000$ ;  $00\frac{1}{2}$ ;  $\frac{1}{2}\frac{1}{2}\frac{1}{2}$ ;  $\frac{1}{2}\frac{1}{2}0$ .  
 (b)  $0\frac{1}{2}0$ ;  $\frac{1}{2}00$ ;  $0\frac{1}{2}\frac{1}{2}$ ;  $\frac{1}{2}0\frac{1}{2}$ .  
 (c)  $00\frac{1}{4}$ ;  $00\frac{3}{4}$ ;  $\frac{1}{2}\frac{1}{2}\frac{3}{4}$ ;  $\frac{1}{2}\frac{1}{2}\frac{1}{4}$ .  
 (d)  $0\frac{1}{2}\frac{1}{4}$ ;  $\frac{1}{2}0\frac{1}{4}$ ;  $\frac{1}{2}0\frac{3}{4}$ ;  $0\frac{1}{2}\frac{3}{4}$ .

Eight equivalent positions:

- (e)  $\frac{1}{2}\frac{1}{2}0$ ;  $\frac{3}{4}\frac{1}{2}0$ ;  $\frac{3}{4}\frac{3}{4}0$ ;  $\frac{1}{2}\frac{3}{4}0$ ;  
 $\frac{3}{4}\frac{3}{4}\frac{1}{2}$ ;  $\frac{1}{2}\frac{3}{4}\frac{1}{2}$ ;  $\frac{1}{2}\frac{1}{2}\frac{1}{2}$ ;  $\frac{3}{4}\frac{1}{2}\frac{1}{2}$ .  
 (f)  $00u$ ;  $\frac{1}{2}\frac{1}{2}u$ ;  $\frac{1}{2}$ ,  $\frac{1}{2}$ ,  $u+\frac{1}{2}$ ;  $0$ ,  $0$ ,  $u+\frac{1}{2}$ ;  
 $00\bar{u}$ ;  $\frac{1}{2}\frac{1}{2}\bar{u}$ ;  $\frac{1}{2}$ ,  $\frac{1}{2}$ ,  $\frac{1}{2}-u$ ;  $0$ ,  $0$ ,  $\frac{1}{2}-u$ .  
 (g)  $0\frac{1}{2}u$ ;  $\frac{1}{2}0u$ ;  $\frac{1}{2}$ ,  $0$ ,  $u+\frac{1}{2}$ ;  $0$ ,  $\frac{1}{2}$ ,  $u+\frac{1}{2}$ ;  
 $0\frac{1}{2}\bar{u}$ ;  $\frac{1}{2}0\bar{u}$ ;  $\frac{1}{2}$ ,  $0$ ,  $\frac{1}{2}-u$ ;  $0$ ,  $\frac{1}{2}$ ,  $\frac{1}{2}-u$ .  
 (h)  $u$ ,  $u+\frac{1}{2}$ ,  $\frac{1}{2}$ ;  $\frac{1}{2}-u$ ,  $u$ ,  $\frac{1}{2}$ ;  $\bar{u}$ ,  $\frac{1}{2}-u$ ,  $\frac{1}{2}$ ;  $u+\frac{1}{2}$ ,  $\bar{u}$ ,  $\frac{1}{2}$ ;  
 $u+\frac{1}{2}$ ,  $u$ ,  $\frac{1}{2}$ ;  $u$ ,  $\frac{1}{2}-u$ ,  $\frac{1}{2}$ ;  $\frac{1}{2}-u$ ,  $\bar{u}$ ,  $\frac{1}{2}$ ;  $\bar{u}$ ,  $u+\frac{1}{2}$ ,  $\frac{1}{2}$ .

Sixteen equivalent positions:

- (i)  $uu0$ ;  $uu\frac{1}{2}$ ;  $u+\frac{1}{2}$ ,  $u+\frac{1}{2}$ ,  $0$ ;  $u+\frac{1}{2}$ ,  $u+\frac{1}{2}$ ,  $\frac{1}{2}$ ;  
 $\bar{u}u0$ ;  $\bar{u}u\frac{1}{2}$ ;  $\frac{1}{2}-u$ ,  $u+\frac{1}{2}$ ,  $0$ ;  $\frac{1}{2}-u$ ,  $u+\frac{1}{2}$ ,  $\frac{1}{2}$ ;  
 $\bar{u}\bar{u}0$ ;  $\bar{u}\bar{u}\frac{1}{2}$ ;  $\frac{1}{2}-u$ ,  $\frac{1}{2}-u$ ,  $0$ ;  $\frac{1}{2}-u$ ,  $\frac{1}{2}-u$ ,  $\frac{1}{2}$ ;  
 $u\bar{u}0$ ;  $u\bar{u}\frac{1}{2}$ ;  $u+\frac{1}{2}$ ,  $\frac{1}{2}-u$ ,  $0$ ;  $u+\frac{1}{2}$ ,  $\frac{1}{2}-u$ ,  $\frac{1}{2}$ .  
 (j)  $u00$ ;  $u0\frac{1}{2}$ ;  $u+\frac{1}{2}$ ,  $\frac{1}{2}$ ,  $0$ ;  $u+\frac{1}{2}$ ,  $\frac{1}{2}$ ,  $\frac{1}{2}$ ;  
 $0u0$ ;  $0u\frac{1}{2}$ ;  $\frac{1}{2}$ ,  $u+\frac{1}{2}$ ,  $0$ ;  $\frac{1}{2}$ ,  $u+\frac{1}{2}$ ,  $\frac{1}{2}$ ;  
 $\bar{u}00$ ;  $\bar{u}0\frac{1}{2}$ ;  $\frac{1}{2}-u$ ,  $\frac{1}{2}$ ,  $0$ ;  $\frac{1}{2}-u$ ,  $\frac{1}{2}$ ,  $\frac{1}{2}$ ;  
 $0\bar{u}0$ ;  $0\bar{u}\frac{1}{2}$ ;  $\frac{1}{2}$ ,  $\frac{1}{2}-u$ ,  $0$ ;  $\frac{1}{2}$ ,  $\frac{1}{2}-u$ ,  $\frac{1}{2}$ .  
 (k)  $uv\frac{1}{4}$ ;  $vuv\frac{3}{4}$ ;  $v+\frac{1}{2}$ ,  $u+\frac{1}{2}$ ,  $\frac{1}{4}$ ;  $u+\frac{1}{2}$ ,  $v+\frac{1}{2}$ ,  $\frac{3}{4}$ ;  
 $\bar{v}u\frac{1}{4}$ ;  $u\bar{v}\frac{3}{4}$ ;  $u+\frac{1}{2}$ ,  $\frac{1}{2}-v$ ,  $\frac{1}{4}$ ;  $\frac{1}{2}-v$ ,  $u+\frac{1}{2}$ ,  $\frac{3}{4}$ ;  
 $\bar{u}\bar{v}\frac{1}{4}$ ;  $\bar{v}\bar{u}\frac{3}{4}$ ;  $\frac{1}{2}-v$ ,  $\frac{1}{2}-u$ ,  $\frac{1}{4}$ ;  $\frac{1}{2}-u$ ,  $\frac{1}{2}-v$ ,  $\frac{3}{4}$ ;  
 $v\bar{u}\frac{1}{4}$ ;  $\bar{u}v\frac{3}{4}$ ;  $\frac{1}{2}-u$ ,  $v+\frac{1}{2}$ ,  $\frac{1}{4}$ ;  $v+\frac{1}{2}$ ,  $\frac{1}{2}-u$ ,  $\frac{3}{4}$ .  
 (l)  $u$ ,  $u+\frac{1}{2}$ ,  $v$ ;  $\frac{1}{2}-u$ ,  $u$ ,  $v$ ;  $\bar{u}$ ,  $\frac{1}{2}-u$ ,  $v$ ;  $u+\frac{1}{2}$ ,  $\bar{u}$ ,  $v$ ;  
 $u+\frac{1}{2}$ ,  $u$ ,  $\bar{v}$ ;  $u$ ,  $\frac{1}{2}-u$ ,  $\bar{v}$ ;  $\frac{1}{2}-u$ ,  $\bar{u}$ ,  $\bar{v}$ ;  $\bar{u}$ ,  $u+\frac{1}{2}$ ,  $\bar{v}$ ;  
 $\bar{u}$ ,  $\frac{1}{2}-u$ ,  $\frac{1}{2}-v$ ;  $u+\frac{1}{2}$ ,  $\bar{u}$ ,  $\frac{1}{2}-v$ ;  $u$ ,  $u+\frac{1}{2}$ ,  $\frac{1}{2}-v$ ;  $\frac{1}{2}-u$ ,  $u$ ,  $\frac{1}{2}-v$ ;  
 $\frac{1}{2}-u$ ,  $\bar{u}$ ,  $v+\frac{1}{2}$ ;  $\bar{u}$ ,  $u+\frac{1}{2}$ ,  $v+\frac{1}{2}$ ;  $u+\frac{1}{2}$ ,  $u$ ,  $v+\frac{1}{2}$ ;  $u$ ,  $\frac{1}{2}-u$ ,  $v+\frac{1}{2}$ .

SPACE-GROUP  $D_{4h}^{18}$  (continued).

Thirty-two equivalent positions:

- (m)  $xyz$ ;  $\bar{y}xz$ ;  $\bar{x}\bar{y}z$ ;  $y\bar{x}z$ ;  
 $yx\bar{z}$ ;  $x\bar{y}\bar{z}$ ;  $\bar{y}\bar{x}\bar{z}$ ;  $\bar{x}y\bar{z}$ ;  
 $\bar{x}, \bar{y}, \frac{1}{2}-z$ ;  $y, \bar{x}, \frac{1}{2}-z$ ;  $x, y, \frac{1}{2}-z$ ;  $\bar{y}, x, \frac{1}{2}-z$ ;  
 $\bar{y}, \bar{x}, z+\frac{1}{2}$ ;  $\bar{x}, y, z+\frac{1}{2}$ ;  $y, x, z+\frac{1}{2}$ ;  $x, \bar{y}, z+\frac{1}{2}$ ;  
 $x+\frac{1}{2}, y+\frac{1}{2}, z+\frac{1}{2}$ ;  $\frac{1}{2}-y, x+\frac{1}{2}, z+\frac{1}{2}$ ;  $\frac{1}{2}-x, \frac{1}{2}-y, z+\frac{1}{2}$ ;  
 $y+\frac{1}{2}, \frac{1}{2}-x, z+\frac{1}{2}$ ;  
 $y+\frac{1}{2}, x+\frac{1}{2}, \frac{1}{2}-z$ ;  $x+\frac{1}{2}, \frac{1}{2}-y, \frac{1}{2}-z$ ;  $\frac{1}{2}-y, \frac{1}{2}-x, \frac{1}{2}-z$ ;  
 $\frac{1}{2}-x, y+\frac{1}{2}, \frac{1}{2}-z$ ;  
 $\frac{1}{2}-x, \frac{1}{2}-y, \bar{z}$ ;  $y+\frac{1}{2}, \frac{1}{2}-x, \bar{z}$ ;  $x+\frac{1}{2}, y+\frac{1}{2}, \bar{z}$ ;  $\frac{1}{2}-y, x+\frac{1}{2}, \bar{z}$ ;  
 $\frac{1}{2}-y, \frac{1}{2}-x, z$ ;  $\frac{1}{2}-x, y+\frac{1}{2}, z$ ;  $y+\frac{1}{2}, x+\frac{1}{2}, z$ ;  $x+\frac{1}{2}, \frac{1}{2}-y, z$ .

SPACE-GROUP  $D_{4h}^{19}$ \*

Four equivalent positions:

- (a)  $000$ ;  $0\frac{1}{2}\frac{1}{2}$ ;  $\frac{1}{2}0\frac{1}{2}$ ;  $\frac{1}{2}\frac{1}{2}0$ .  
 (b)  $00\frac{1}{2}$ ;  $0\frac{1}{2}\frac{1}{2}$ ;  $\frac{1}{2}0\frac{1}{2}$ ;  $\frac{1}{2}\frac{1}{2}0$ .

Eight equivalent positions:

- (c)  $0\frac{1}{2}\frac{1}{2}$ ;  $\frac{1}{2}\frac{1}{2}\frac{1}{2}$ ;  $0\frac{1}{2}\frac{1}{2}$ ;  $\frac{1}{2}0\frac{1}{2}$ ;  
 $\frac{1}{2}\frac{1}{2}\frac{1}{2}$ ;  $\frac{1}{2}\frac{1}{2}\frac{1}{2}$ ;  $\frac{1}{2}\frac{1}{2}\frac{1}{2}$ ;  $\frac{1}{2}0\frac{1}{2}$ .  
 (d)  $\frac{1}{2}\frac{1}{2}\frac{1}{2}$ ;  $\frac{1}{2}0\frac{1}{2}$ ;  $\frac{1}{2}\frac{1}{2}\frac{1}{2}$ ;  $\frac{1}{2}\frac{1}{2}\frac{1}{2}$ ;  
 $0\frac{1}{2}\frac{1}{2}$ ;  $\frac{1}{2}0\frac{1}{2}$ ;  $0\frac{1}{2}\frac{1}{2}$ ;  $\frac{1}{2}\frac{1}{2}\frac{1}{2}$ .  
 (e)  $00u$ ;  $0, \frac{1}{2}, u+\frac{1}{2}$ ;  $\frac{1}{2}, \frac{1}{2}, u+\frac{1}{2}$ ;  $\frac{1}{2}, 0, u+\frac{1}{2}$ ;  
 $00\bar{u}$ ;  $0, \frac{1}{2}, \frac{1}{2}-u$ ;  $\frac{1}{2}, \frac{1}{2}, \frac{1}{2}-u$ ;  $\frac{1}{2}, 0, \frac{1}{2}-u$ .

Sixteen equivalent positions:

- (f)  $u\frac{1}{2}\frac{1}{2}$ ;  $\frac{1}{2}, \frac{1}{2}-u, \frac{1}{2}$ ;  $\bar{u}\frac{1}{2}\frac{1}{2}$ ;  $\frac{1}{2}u\frac{1}{2}$ ;  
 $u+\frac{1}{2}, \frac{1}{2}, \frac{1}{2}$ ;  $\frac{1}{2}, \frac{1}{2}-u, \frac{1}{2}$ ;  $\frac{1}{2}-u, \frac{1}{2}, \frac{1}{2}$ ;  $\frac{1}{2}u\frac{1}{2}$ ;  
 $\bar{u}\frac{1}{2}\frac{1}{2}$ ;  $\frac{1}{2}, u+\frac{1}{2}, \frac{1}{2}$ ;  $u\frac{1}{2}\frac{1}{2}$ ;  $\frac{1}{2}\bar{u}\frac{1}{2}$ ;  
 $\frac{1}{2}-u, \frac{1}{2}, \frac{1}{2}$ ;  $\frac{1}{2}, u+\frac{1}{2}, \frac{1}{2}$ ;  $u+\frac{1}{2}, \frac{1}{2}, \frac{1}{2}$ ;  $\frac{1}{2}\bar{u}\frac{1}{2}$ .  
 (g)  $uu0$ ;  $u, \frac{1}{2}-u, \frac{1}{2}$ ;  $\bar{u}\bar{u}0$ ;  $\frac{1}{2}-u, u, \frac{1}{2}$ ;  
 $u+\frac{1}{2}, u, \frac{1}{2}$ ;  $u+\frac{1}{2}, \frac{1}{2}-u, \frac{1}{2}$ ;  $\frac{1}{2}-u, \bar{u}, \frac{1}{2}$ ;  $\bar{u}, u+\frac{1}{2}, \frac{1}{2}$ ;  
 $\bar{u}u0$ ;  $\bar{u}, \frac{1}{2}-u, \frac{1}{2}$ ;  $u\bar{u}0$ ;  $u, u+\frac{1}{2}, \frac{1}{2}$ ;  
 $\frac{1}{2}-u, u+\frac{1}{2}, \frac{1}{2}$ ;  $\frac{1}{2}-u, \frac{1}{2}-u, \frac{1}{2}$ ;  $u+\frac{1}{2}, \bar{u}, \frac{1}{2}$ ;  $u+\frac{1}{2}, u+\frac{1}{2}, \frac{1}{2}$ .  
 (h)  $0uv$ ;  $u, \frac{1}{2}, v+\frac{1}{2}$ ;  $0\bar{u}v$ ;  $\frac{1}{2}-u, 0, v+\frac{1}{2}$ ;  
 $\frac{1}{2}, u, \frac{1}{2}-v$ ;  $u+\frac{1}{2}, \frac{1}{2}, \frac{1}{2}-v$ ;  $\frac{1}{2}, \bar{u}, \frac{1}{2}-v$ ;  $\bar{u}0\bar{v}$ ;  
 $\frac{1}{2}, u+\frac{1}{2}, v+\frac{1}{2}$ ;  $u+\frac{1}{2}, 0, v+\frac{1}{2}$ ;  $\frac{1}{2}, \frac{1}{2}-u, v+\frac{1}{2}$ ;  $\bar{u}, \frac{1}{2}, v+\frac{1}{2}$ ;  
 $0, u+\frac{1}{2}, \frac{1}{2}-v$ ;  $u0\bar{v}$ ;  $0, \frac{1}{2}-u, \frac{1}{2}-v$ ;  $\frac{1}{2}-u, \frac{1}{2}, \frac{1}{2}-v$ .

Thirty-two equivalent positions:

- (i)  $xyz$ ;  $y, \frac{1}{2}-x, z+\frac{1}{2}$ ;  $\bar{x}\bar{y}z$ ;  $\frac{1}{2}-y, x, z+\frac{1}{2}$ ;  
 $x+\frac{1}{2}, y, \frac{1}{2}-z$ ;  $y+\frac{1}{2}, \frac{1}{2}-x, \frac{1}{2}-z$ ;  $\frac{1}{2}-x, \bar{y}, \frac{1}{2}-z$ ;  $\bar{y}x\bar{z}$ ;  
 $\bar{x}yz$ ;  $\bar{y}, \frac{1}{2}-x, z+\frac{1}{2}$ ;  $x\bar{y}z$ ;  $y+\frac{1}{2}, x, z+\frac{1}{2}$ ;  
 $\frac{1}{2}-x, y, \frac{1}{2}-z$ ;  $\frac{1}{2}-y, \frac{1}{2}-x, \frac{1}{2}-z$ ;  $x+\frac{1}{2}, \bar{y}, \frac{1}{2}-z$ ;  $yx\bar{z}$ ;  
 $x+\frac{1}{2}, y+\frac{1}{2}, z+\frac{1}{2}$ ;  $y+\frac{1}{2}, \bar{x}, z+\frac{1}{2}$ ;  $\frac{1}{2}-x, \frac{1}{2}-y, z+\frac{1}{2}$ ;  
 $\bar{y}, x+\frac{1}{2}, z+\frac{1}{2}$ ;  
 $x, y+\frac{1}{2}, \frac{1}{2}-z$ ;  $y\bar{x}\bar{z}$ ;  $\bar{x}, \frac{1}{2}-y, \frac{1}{2}-z$ ;  $\frac{1}{2}-y, x+\frac{1}{2}, \frac{1}{2}-z$ ;  
 $\frac{1}{2}-x, y+\frac{1}{2}, z+\frac{1}{2}$ ;  $\frac{1}{2}-y, \bar{x}, z+\frac{1}{2}$ ;  $x+\frac{1}{2}, \frac{1}{2}-y, z+\frac{1}{2}$ ;  
 $y, x+\frac{1}{2}, z+\frac{1}{2}$ ;  
 $\bar{x}, y+\frac{1}{2}, \frac{1}{2}-z$ ;  $\bar{y}x\bar{z}$ ;  $x, \frac{1}{2}-y, \frac{1}{2}-z$ ;  $y+\frac{1}{2}, x+\frac{1}{2}, \frac{1}{2}-z$ .

SPACE-GROUP  $D_{2d}^{20}$  \**Eight equivalent positions:*

- (a)  $000$ ;  $0\frac{1}{2}\frac{1}{2}$ ;  $\frac{1}{2}0\frac{1}{2}$ ;  $\frac{1}{2}\frac{1}{2}0$ ;  
 $00\frac{1}{2}$ ;  $0\frac{1}{2}\frac{1}{2}$ ;  $\frac{1}{2}0\frac{1}{2}$ ;  $\frac{1}{2}\frac{1}{2}\frac{1}{2}$ .  
 (b)  $00\frac{1}{2}$ ;  $0\frac{1}{2}\frac{1}{2}$ ;  $\frac{1}{2}00$ ;  $\frac{1}{2}\frac{1}{2}\frac{1}{2}$ ;  
 $00\frac{1}{2}$ ;  $0\frac{1}{2}0$ ;  $\frac{1}{2}0\frac{1}{2}$ ;  $\frac{1}{2}\frac{1}{2}\frac{1}{2}$ .

*Sixteen equivalent positions:*

- (c)  $0\frac{1}{2}\frac{1}{2}$ ;  $\frac{1}{2}\frac{1}{2}\frac{1}{2}$ ;  $0\frac{1}{2}\frac{1}{2}$ ;  $\frac{1}{2}0\frac{1}{2}$ ;  
 $\frac{1}{2}\frac{1}{2}\frac{1}{2}$ ;  $\frac{1}{2}\frac{1}{2}\frac{1}{2}$ ;  $\frac{1}{2}\frac{1}{2}\frac{1}{2}$ ;  $\frac{1}{2}0\frac{1}{2}$ ;  
 $0\frac{1}{2}\frac{1}{2}$ ;  $\frac{1}{2}\frac{1}{2}\frac{1}{2}$ ;  $0\frac{1}{2}\frac{1}{2}$ ;  $\frac{1}{2}0\frac{1}{2}$ ;  
 $\frac{1}{2}\frac{1}{2}\frac{1}{2}$ ;  $\frac{1}{2}\frac{1}{2}\frac{1}{2}$ ;  $\frac{1}{2}\frac{1}{2}\frac{1}{2}$ ;  $\frac{1}{2}0\frac{1}{2}$ .  
 (d)  $00u$ ;  $0, \frac{1}{2}, u+\frac{1}{2}$ ;  $\frac{1}{2}, 0, u+\frac{1}{2}$ ;  $\frac{1}{2}, \frac{1}{2}, u+\frac{1}{2}$ ;  
 $00\bar{u}$ ;  $0, \frac{1}{2}, u+\frac{1}{2}$ ;  $\frac{1}{2}, 0, u+\frac{1}{2}$ ;  $\frac{1}{2}, \frac{1}{2}, \frac{1}{2}-u$ ;  
 $\frac{1}{2}\frac{1}{2}u$ ;  $0, \frac{1}{2}, \frac{1}{2}-u$ ;  $\frac{1}{2}, 0, \frac{1}{2}-u$ ;  $0, 0, \frac{1}{2}-u$ ;  
 $\frac{1}{2}\frac{1}{2}\bar{u}$ ;  $0, \frac{1}{2}, \frac{1}{2}-u$ ;  $\frac{1}{2}, 0, \frac{1}{2}-u$ ;  $0, 0, u+\frac{1}{2}$ .  
 (e)  $u\frac{1}{2}\frac{1}{2}$ ;  $\frac{1}{2}, \frac{1}{2}-u, \frac{1}{2}$ ;  $\bar{u}\frac{1}{2}\frac{1}{2}$ ;  $\frac{1}{2}u\frac{1}{2}$ ;  
 $u+\frac{1}{2}, \frac{1}{2}, \frac{1}{2}$ ;  $\frac{1}{2}, \frac{1}{2}-u, \frac{1}{2}$ ;  $\frac{1}{2}-u, \frac{1}{2}, \frac{1}{2}$ ;  $\frac{1}{2}u\frac{1}{2}$ ;  
 $\bar{u}\frac{1}{2}\frac{1}{2}$ ;  $\frac{1}{2}-u, \frac{1}{2}, \frac{1}{2}$ ;  $\frac{1}{2}, u+\frac{1}{2}, \frac{1}{2}$ ;  $\frac{1}{2}\bar{u}\frac{1}{2}$ ;  
 $u\frac{1}{2}\frac{1}{2}$ ;  $u+\frac{1}{2}, \frac{1}{2}, \frac{1}{2}$ ;  $\frac{1}{2}, u+\frac{1}{2}, \frac{1}{2}$ ;  $\frac{1}{2}\bar{u}\frac{1}{2}$ .  
 (f)  $uu0$ ;  $u, \frac{1}{2}-u, \frac{1}{2}$ ;  $\bar{u}\bar{u}0$ ;  $\frac{1}{2}-u, u, \frac{1}{2}$ ;  
 $u+\frac{1}{2}, u, \frac{1}{2}$ ;  $u+\frac{1}{2}, \frac{1}{2}-u, 0$ ;  $\frac{1}{2}-u, u, \frac{1}{2}$ ;  $\bar{u}u\frac{1}{2}$ ;  
 $u+\frac{1}{2}, u+\frac{1}{2}, \frac{1}{2}$ ;  $u+\frac{1}{2}, \bar{u}, \frac{1}{2}$ ;  $\frac{1}{2}-u, \frac{1}{2}-u, \frac{1}{2}$ ;  $\bar{u}, u+\frac{1}{2}, \frac{1}{2}$ ;  
 $u, u+\frac{1}{2}, \frac{1}{2}$ ;  $u\bar{u}\frac{1}{2}$ ;  $\bar{u}, \frac{1}{2}-u, \frac{1}{2}$ ;  $\frac{1}{2}-u, u+\frac{1}{2}, 0$ .

*Thirty-two equivalent positions:*

- (g)  $xyz$ ;  $y, \frac{1}{2}-x, z+\frac{1}{2}$ ;  $\bar{x}\bar{y}\bar{z}$ ;  $\frac{1}{2}-y, x, z+\frac{1}{2}$ ;  
 $x+\frac{1}{2}, y, \frac{1}{2}-z$ ;  $y+\frac{1}{2}, \frac{1}{2}-x, \bar{z}$ ;  $\frac{1}{2}-x, \bar{y}, \frac{1}{2}-z$ ;  $\bar{y}, x, \frac{1}{2}-z$ ;  
 $\bar{x}, y, z+\frac{1}{2}$ ;  $\bar{y}, \frac{1}{2}-x, z+\frac{1}{2}$ ;  $x, \bar{y}, z+\frac{1}{2}$ ;  $y+\frac{1}{2}, x, z+\frac{1}{2}$ ;  
 $\frac{1}{2}-x, y, \frac{1}{2}-z$ ;  $\frac{1}{2}-y, \frac{1}{2}-x, \frac{1}{2}-z$ ;  $x+\frac{1}{2}, \bar{y}, \frac{1}{2}-z$ ;  $y\bar{x}\bar{z}$ ;  
 $x+\frac{1}{2}, y+\frac{1}{2}, z+\frac{1}{2}$ ;  $y+\frac{1}{2}, \bar{x}, z+\frac{1}{2}$ ;  $\frac{1}{2}-x, \frac{1}{2}-y, z+\frac{1}{2}$ ;  
 $\bar{y}, x+\frac{1}{2}, z+\frac{1}{2}$ ;  
 $x, y+\frac{1}{2}, \frac{1}{2}-z$ ;  $y, \bar{x}, \frac{1}{2}-z$ ;  $\bar{x}, \frac{1}{2}-y, \frac{1}{2}-z$ ;  $\frac{1}{2}-y, x+\frac{1}{2}, \bar{z}$ ;  
 $\frac{1}{2}-x, y+\frac{1}{2}, z$ ;  $\frac{1}{2}-y, \bar{x}, z+\frac{1}{2}$ ;  $x+\frac{1}{2}, \frac{1}{2}-y, z$ ;  $y, x+\frac{1}{2}, z+\frac{1}{2}$ ;  
 $\bar{x}, y+\frac{1}{2}, \frac{1}{2}-z$ ;  $\bar{y}\bar{x}\bar{z}$ ;  $x, \frac{1}{2}-y, \frac{1}{2}-z$ ;  $y+\frac{1}{2}, x+\frac{1}{2}, \frac{1}{2}-z$ .

## CUBIC SYSTEM.

## THE SPECIAL CASES OF THE CUBIC SPACE-GROUPS.

## ONE EQUIVALENT POSITION.

(1a)  $000$ . (1b)  $\frac{1}{2}\frac{1}{2}\frac{1}{2}$ .

## TWO EQUIVALENT POSITIONS.

(2a)  $000$ ;  $\frac{1}{2}\frac{1}{2}\frac{1}{2}$ .

## THREE EQUIVALENT POSITIONS.

(3a)  $\frac{1}{2}\frac{1}{2}0$ ;  $\frac{1}{2}0\frac{1}{2}$ ;  $0\frac{1}{2}\frac{1}{2}$ . (3b)  $\frac{1}{2}00$ ;  $0\frac{1}{2}0$ ;  $00\frac{1}{2}$ .

## FOUR EQUIVALENT POSITIONS.

(4a)  $uuu$ ;  $u\bar{u}\bar{u}$ ;  $\bar{u}u\bar{u}$ ;  $\bar{u}\bar{u}u$ .

(4b)  $000$ ;  $\frac{1}{2}\frac{1}{2}0$ ;  $\frac{1}{2}0\frac{1}{2}$ ;  $0\frac{1}{2}\frac{1}{2}$ .

(4c)  $\frac{1}{2}\frac{1}{2}\frac{1}{2}$ ;  $\frac{1}{2}00$ ;  $0\frac{1}{2}0$ ;  $00\frac{1}{2}$ .

(4d)  $\frac{1}{2}\frac{1}{2}\frac{1}{2}$ ;  $\frac{1}{2}\frac{1}{2}\frac{1}{2}$ ;  $\frac{1}{2}\frac{1}{2}\frac{1}{2}$ ;  $\frac{1}{2}\frac{1}{2}\frac{1}{2}$ .

(4e)  $\frac{1}{2}\frac{1}{2}\frac{1}{2}$ ;  $\frac{1}{2}\frac{1}{2}\frac{1}{2}$ ;  $\frac{1}{2}\frac{1}{2}\frac{1}{2}$ ;  $\frac{1}{2}\frac{1}{2}\frac{1}{2}$ .

(4f)  $uuu$ ;  $u+\frac{1}{2}$ ,  $\frac{1}{2}-u$ ,  $\bar{u}$ ;  $\bar{u}$ ,  $u+\frac{1}{2}$ ,  $\frac{1}{2}-u$ ;  $\frac{1}{2}-u$ ,  $\bar{u}$ ,  $u+\frac{1}{2}$ .

(4g)  $\frac{1}{2}\frac{1}{2}\frac{1}{2}$ ;  $\frac{1}{2}\frac{1}{2}\frac{1}{2}$ ;  $\frac{1}{2}\frac{1}{2}\frac{1}{2}$ ;  $\frac{1}{2}\frac{1}{2}\frac{1}{2}$ .

(4h)  $\frac{1}{2}\frac{1}{2}\frac{1}{2}$ ;  $\frac{1}{2}\frac{1}{2}\frac{1}{2}$ ;  $\frac{1}{2}\frac{1}{2}\frac{1}{2}$ ;  $\frac{1}{2}\frac{1}{2}\frac{1}{2}$ .

(4i)  $\frac{1}{2}\frac{1}{2}\frac{1}{2}$ ;  $\frac{1}{2}\frac{1}{2}\frac{1}{2}$ ;  $\frac{1}{2}\frac{1}{2}\frac{1}{2}$ ;  $\frac{1}{2}\frac{1}{2}\frac{1}{2}$ .

(4j)  $\frac{1}{2}\frac{1}{2}\frac{1}{2}$ ;  $\frac{1}{2}\frac{1}{2}\frac{1}{2}$ ;  $\frac{1}{2}\frac{1}{2}\frac{1}{2}$ ;  $\frac{1}{2}\frac{1}{2}\frac{1}{2}$ .

## SIX EQUIVALENT POSITIONS.

(6a)  $u00$ ;  $0u0$ ;  $00u$ ; (6e)  $0\frac{1}{2}0$ ;  $00\frac{1}{2}$ ;  $\frac{1}{2}00$ ;  
 $\bar{u}00$ ;  $0\bar{u}0$ ;  $00\bar{u}$ .  $\frac{1}{2}0\frac{1}{2}$ ;  $\frac{1}{2}\frac{1}{2}0$ ;  $0\frac{1}{2}\frac{1}{2}$ .

(6b)  $\frac{1}{2}u0$ ;  $0\frac{1}{2}u$ ;  $u0\frac{1}{2}$ ; (6f)  $0\frac{1}{2}\frac{1}{2}$ ;  $\frac{1}{2}0\frac{1}{2}$ ;  $\frac{1}{2}\frac{1}{2}0$ ;  
 $\frac{1}{2}\bar{u}0$ ;  $0\frac{1}{2}\bar{u}$ ;  $\bar{u}0\frac{1}{2}$ .  $0\frac{1}{2}\frac{1}{2}$ ;  $\frac{1}{2}0\frac{1}{2}$ ;  $\frac{1}{2}\frac{1}{2}0$ .

(6c)  $0u\frac{1}{2}$ ;  $\frac{1}{2}0u$ ;  $u\frac{1}{2}0$ ; (6g)  $\frac{1}{2}0\frac{1}{2}$ ;  $\frac{1}{2}\frac{1}{2}0$ ;  $0\frac{1}{2}\frac{1}{2}$ ;  
 $0\bar{u}\frac{1}{2}$ ;  $\frac{1}{2}0\bar{u}$ ;  $\bar{u}\frac{1}{2}0$ .  $\frac{1}{2}0\frac{1}{2}$ ;  $\frac{1}{2}\frac{1}{2}0$ ;  $0\frac{1}{2}\frac{1}{2}$ .

(6d)  $\frac{1}{2}u\frac{1}{2}$ ;  $\frac{1}{2}\frac{1}{2}u$ ;  $u\frac{1}{2}\frac{1}{2}$ ;  
 $\frac{1}{2}\bar{u}\frac{1}{2}$ ;  $\frac{1}{2}\frac{1}{2}\bar{u}$ ;  $\bar{u}\frac{1}{2}\frac{1}{2}$ .

## EIGHT EQUIVALENT POSITIONS.

(8a)  $uuu$ ;  $\bar{u}\bar{u}\bar{u}$ ;  $u+\frac{1}{2}$ ,  $u+\frac{1}{2}$ ,  $u+\frac{1}{2}$ ;  $\frac{1}{2}-u$ ,  $u+\frac{1}{2}$ ,  $\frac{1}{2}-u$ ;  
 $u\bar{u}\bar{u}$ ;  $\bar{u}\bar{u}u$ ;  $u+\frac{1}{2}$ ,  $\frac{1}{2}-u$ ,  $\frac{1}{2}-u$ ;  $\frac{1}{2}-u$ ,  $\frac{1}{2}-u$ ,  $u+\frac{1}{2}$ .

(8b)  $uuu$ ;  $\frac{1}{2}-u$ ,  $u$ ,  $\bar{u}$ ;  $u+\frac{1}{2}$ ,  $u+\frac{1}{2}$ ,  $u+\frac{1}{2}$ ;  $\bar{u}$ ,  $u+\frac{1}{2}$ ,  $\frac{1}{2}-u$ ;  
 $u$ ,  $\bar{u}$ ,  $\frac{1}{2}-u$ ;  $\bar{u}$ ,  $\frac{1}{2}-u$ ,  $u$ ;  $u+\frac{1}{2}$ ,  $\frac{1}{2}-u$ ,  $\bar{u}$ ;  $\frac{1}{2}-u$ ,  $\bar{u}$ ,  $u+\frac{1}{2}$ .

(8c)  $uuu$ ;  $u\bar{u}\bar{u}$ ;  $\bar{u}u\bar{u}$ ;  $\bar{u}\bar{u}u$ ;

$\bar{u}\bar{u}\bar{u}$ ;  $\bar{u}uu$ ;  $u\bar{u}u$ ;  $uu\bar{u}$ .

(8d)  $uuu$ ;  $\bar{u}\bar{u}\bar{u}$ ;  $\frac{1}{2}-u$ ,  $\frac{1}{2}-u$ ,  $\frac{1}{2}-u$ ;  $u+\frac{1}{2}$ ,  $\frac{1}{2}-u$ ,  $u+\frac{1}{2}$ ;

$u\bar{u}\bar{u}$ ;  $\bar{u}\bar{u}u$ ;  $\frac{1}{2}-u$ ,  $u+\frac{1}{2}$ ,  $u+\frac{1}{2}$ ;  $u+\frac{1}{2}$ ,  $u+\frac{1}{2}$ ,  $\frac{1}{2}-u$ .

(8e)  $\frac{1}{2}\frac{1}{2}\frac{1}{2}$ ;  $\frac{1}{2}\frac{1}{2}\frac{1}{2}$ ;  $\frac{1}{2}\frac{1}{2}\frac{1}{2}$ ;  $\frac{1}{2}\frac{1}{2}\frac{1}{2}$ ;

$\frac{1}{2}\frac{1}{2}\frac{1}{2}$ ;  $\frac{1}{2}\frac{1}{2}\frac{1}{2}$ ;  $\frac{1}{2}\frac{1}{2}\frac{1}{2}$ ;  $\frac{1}{2}\frac{1}{2}\frac{1}{2}$ .

## EIGHT EQUIVALENT POSITIONS.—Continued.

- (8f)  $0\frac{1}{2}\frac{1}{2}$ ;  $\frac{1}{2}0\frac{1}{2}$ ;  $\frac{1}{2}\frac{1}{2}0$ ;  $000$ ;  
 $\frac{1}{2}\frac{1}{2}\frac{1}{2}$ ;  $\frac{1}{2}\frac{1}{2}\frac{1}{2}$ ;  $\frac{1}{2}\frac{1}{2}\frac{1}{2}$ ;  $\frac{1}{2}\frac{1}{2}\frac{1}{2}$ .
- (8g)  $\frac{1}{2}00$ ;  $0\frac{1}{2}0$ ;  $00\frac{1}{2}$ ;  $\frac{1}{2}\frac{1}{2}\frac{1}{2}$ ;  
 $\frac{1}{2}\frac{1}{2}\frac{1}{2}$ ;  $\frac{1}{2}\frac{1}{2}\frac{1}{2}$ ;  $\frac{1}{2}\frac{1}{2}\frac{1}{2}$ ;  $\frac{1}{2}\frac{1}{2}\frac{1}{2}$ .
- (8h)  $uuu$ ;  $u+\frac{1}{2}$ ,  $\frac{1}{2}-u$ ,  $\bar{u}$ ;  $\bar{u}$ ,  $u+\frac{1}{2}$ ,  $\frac{1}{2}-u$ ;  $\frac{1}{2}-u$ ,  $\bar{u}$ ,  $u+\frac{1}{2}$ ;  
 $\bar{u}\bar{u}\bar{u}$ ;  $\frac{1}{2}-u$ ,  $u+\frac{1}{2}$ ,  $u$ ;  $u$ ,  $\frac{1}{2}-u$ ,  $u+\frac{1}{2}$ ;  $u+\frac{1}{2}$ ,  $u$ ,  $\frac{1}{2}-u$ .
- (8i)  $000$ ;  $\frac{1}{2}\frac{1}{2}0$ ;  $\frac{1}{2}0\frac{1}{2}$ ;  $0\frac{1}{2}\frac{1}{2}$ ;  
 $\frac{1}{2}\frac{1}{2}\frac{1}{2}$ ;  $00\frac{1}{2}$ ;  $0\frac{1}{2}0$ ;  $\frac{1}{2}00$ .
- (8j)  $uuu$ ;  $u+\frac{1}{2}$ ,  $\frac{1}{2}-u$ ,  $\bar{u}$ ;  $\bar{u}$ ,  $u+\frac{1}{2}$ ,  $\frac{1}{2}-u$ ;  $\frac{1}{2}-u$ ,  $\bar{u}$ ,  $u+\frac{1}{2}$ ;  
 $\frac{1}{2}-u$ ,  $\frac{1}{2}-u$ ,  $\frac{1}{2}-u$ ;  $u+\frac{1}{2}$ ,  $\frac{1}{2}-u$ ,  $u+\frac{1}{2}$ ;  $\frac{1}{2}-u$ ,  $u+\frac{1}{2}$ ,  $u+\frac{1}{2}$ ;  
 $u+\frac{1}{2}$ ,  $u+\frac{1}{2}$ ,  $\frac{1}{2}-u$ .
- (8k)  $uuu$ ;  $u+\frac{1}{2}$ ,  $\frac{1}{2}-u$ ,  $\bar{u}$ ;  $\bar{u}$ ,  $u+\frac{1}{2}$ ,  $\frac{1}{2}-u$ ;  $\frac{1}{2}-u$ ,  $\bar{u}$ ,  $u+\frac{1}{2}$ ;  
 $\frac{1}{2}-u$ ,  $\frac{1}{2}-u$ ,  $\frac{1}{2}-u$ ;  $u+\frac{1}{2}$ ,  $\frac{1}{2}-u$ ,  $u+\frac{1}{2}$ ;  $\frac{1}{2}-u$ ,  $u+\frac{1}{2}$ ,  $u+\frac{1}{2}$ ;  
 $u+\frac{1}{2}$ ;  $u+\frac{1}{2}$ ,  $\frac{1}{2}-u$ .
- (8l)  $\frac{1}{2}\frac{1}{2}\frac{1}{2}$ ;  $\frac{1}{2}\frac{1}{2}\frac{1}{2}$ ;  $\frac{1}{2}\frac{1}{2}\frac{1}{2}$ ;  $\frac{1}{2}\frac{1}{2}\frac{1}{2}$ ;  
 $\frac{1}{2}\frac{1}{2}\frac{1}{2}$ ;  $\frac{1}{2}\frac{1}{2}\frac{1}{2}$ ;  $\frac{1}{2}\frac{1}{2}\frac{1}{2}$ ;  $\frac{1}{2}\frac{1}{2}\frac{1}{2}$ .
- (8m)  $\frac{1}{2}\frac{1}{2}\frac{1}{2}$ ;  $\frac{1}{2}\frac{1}{2}\frac{1}{2}$ ;  $\frac{1}{2}\frac{1}{2}\frac{1}{2}$ ;  $\frac{1}{2}\frac{1}{2}\frac{1}{2}$ ;  
 $\frac{1}{2}\frac{1}{2}\frac{1}{2}$ ;  $\frac{1}{2}\frac{1}{2}\frac{1}{2}$ ;  $\frac{1}{2}\frac{1}{2}\frac{1}{2}$ ;  $\frac{1}{2}\frac{1}{2}\frac{1}{2}$ .

## TWELVE EQUIVALENT POSITIONS.

- (12a)  $u00$ ;  $\bar{u}00$ ;  $u+\frac{1}{2}$ ,  $\frac{1}{2}$ ,  $\frac{1}{2}$ ;  $\frac{1}{2}-u$ ,  $\frac{1}{2}$ ,  $\frac{1}{2}$ ;  
 $0u0$ ;  $0\bar{u}0$ ;  $\frac{1}{2}$ ,  $u+\frac{1}{2}$ ,  $\frac{1}{2}$ ;  $\frac{1}{2}$ ,  $\frac{1}{2}-u$ ,  $\frac{1}{2}$ ;  
 $00u$ ;  $00\bar{u}$ ;  $\frac{1}{2}$ ,  $\frac{1}{2}$ ,  $u+\frac{1}{2}$ ;  $\frac{1}{2}$ ,  $\frac{1}{2}$ ,  $\frac{1}{2}-u$ .
- (12b)  $u\frac{1}{2}0$ ;  $\bar{u}\frac{1}{2}0$ ;  $u+\frac{1}{2}$ ,  $0$ ,  $\frac{1}{2}$ ;  $\frac{1}{2}-u$ ,  $0$ ,  $\frac{1}{2}$ ;  
 $0u\frac{1}{2}$ ;  $0\bar{u}\frac{1}{2}$ ;  $\frac{1}{2}$ ,  $u+\frac{1}{2}$ ,  $0$ ;  $\frac{1}{2}$ ,  $\frac{1}{2}-u$ ,  $0$ ;  
 $\frac{1}{2}0u$ ;  $\frac{1}{2}0\bar{u}$ ;  $0$ ,  $\frac{1}{2}$ ,  $u+\frac{1}{2}$ ;  $0$ ,  $\frac{1}{2}$ ,  $\frac{1}{2}-u$ .
- (12c)  $u0\frac{1}{2}$ ;  $\bar{u}0\frac{1}{2}$ ;  $u+\frac{1}{2}$ ,  $\frac{1}{2}$ ,  $\frac{1}{2}$ ;  $\frac{1}{2}-u$ ,  $0$ ,  $\frac{1}{2}$ ;  
 $\frac{1}{2}u0$ ;  $\frac{1}{2}\bar{u}0$ ;  $\frac{1}{2}$ ,  $u+\frac{1}{2}$ ,  $\frac{1}{2}$ ;  $\frac{1}{2}$ ,  $\frac{1}{2}-u$ ,  $0$ ;  
 $0\frac{1}{2}u$ ;  $0\frac{1}{2}\bar{u}$ ;  $\frac{1}{2}$ ,  $\frac{1}{2}$ ,  $u+\frac{1}{2}$ ;  $0$ ,  $\frac{1}{2}$ ,  $\frac{1}{2}-u$ .
- (12d)  $0uv$ ;  $0\bar{u}\bar{v}$ ;  $0u\bar{v}$ ;  $0\bar{u}v$ ;  
 $v0u$ ;  $\bar{v}0\bar{u}$ ;  $\bar{v}0u$ ;  $v0\bar{u}$ ;  
 $uv0$ ;  $\bar{u}\bar{v}0$ ;  $u\bar{v}0$ ;  $\bar{u}v0$ .
- (12e)  $\frac{1}{2}uv$ ;  $\frac{1}{2}\bar{u}\bar{v}$ ;  $\frac{1}{2}u\bar{v}$ ;  $\frac{1}{2}\bar{u}v$ ;  
 $v\frac{1}{2}u$ ;  $\bar{v}\frac{1}{2}\bar{u}$ ;  $\bar{v}\frac{1}{2}u$ ;  $v\frac{1}{2}\bar{u}$ ;  
 $uv\frac{1}{2}$ ;  $\bar{u}\bar{v}\frac{1}{2}$ ;  $u\bar{v}\frac{1}{2}$ ;  $\bar{u}v\frac{1}{2}$ .
- (12f)  $u0\frac{1}{2}$ ;  $\bar{u}0\frac{1}{2}$ ;  $u\frac{1}{2}0$ ;  $\bar{u}\frac{1}{2}0$ ;  
 $\frac{1}{2}u0$ ;  $\frac{1}{2}\bar{u}0$ ;  $0u\frac{1}{2}$ ;  $0\bar{u}\frac{1}{2}$ ;  
 $0\frac{1}{2}u$ ;  $0\frac{1}{2}\bar{u}$ ;  $\frac{1}{2}0u$ ;  $\frac{1}{2}0\bar{u}$ .
- (12g)  $uu\bar{v}$ ;  $u\bar{u}\bar{v}$ ;  $\bar{u}u\bar{v}$ ;  $\bar{u}\bar{u}v$ ;  
 $vuu$ ;  $\bar{v}u\bar{u}$ ;  $\bar{v}\bar{u}u$ ;  $v\bar{u}\bar{u}$ ;  
 $uvu$ ;  $\bar{u}\bar{v}u$ ;  $u\bar{v}\bar{u}$ ;  $\bar{u}v\bar{u}$ .
- (12h)  $\frac{1}{2}0\frac{1}{2}$ ;  $\frac{1}{2}0\frac{1}{2}$ ;  $0\frac{1}{2}\frac{1}{2}$ ;  $0\frac{1}{2}\frac{1}{2}$ ;  
 $\frac{1}{2}\frac{1}{2}0$ ;  $\frac{1}{2}\frac{1}{2}0$ ;  $\frac{1}{2}\frac{1}{2}0$ ;  $\frac{1}{2}\frac{1}{2}0$ ;  
 $0\frac{1}{2}\frac{1}{2}$ ;  $0\frac{1}{2}\frac{1}{2}$ ;  $\frac{1}{2}0\frac{1}{2}$ ;  $\frac{1}{2}0\frac{1}{2}$ .

TWELVE EQUIVALENT POSITIONS.—*Continued.*

- (12i)  $u0\frac{1}{2}$ ;  $\bar{u}0\frac{1}{2}$ ;  $u+\frac{1}{2}, 0, \frac{1}{2}$ ;  $\frac{1}{2}-u, 0, \frac{1}{2}$ ;  
 $\frac{1}{2}u0$ ;  $\frac{1}{2}\bar{u}0$ ;  $\frac{1}{2}, u+\frac{1}{2}, 0$ ;  $\frac{1}{2}, \frac{1}{2}-u, 0$ ;  
 $0\frac{1}{2}u$ ;  $0\frac{1}{2}\bar{u}$ ;  $0, \frac{1}{2}, u+\frac{1}{2}$ ;  $0, \frac{1}{2}, \frac{1}{2}-u$ .
- (12j)  $u\frac{1}{2}0$ ;  $\bar{u}\frac{1}{2}0$ ;  $u+\frac{1}{2}, \frac{1}{2}, 0$ ;  $\frac{1}{2}-u, \frac{1}{2}, 0$ ;  
 $0u\frac{1}{2}$ ;  $0\bar{u}\frac{1}{2}$ ;  $0, u+\frac{1}{2}, \frac{1}{2}$ ;  $0, \frac{1}{2}-u, \frac{1}{2}$ ;  
 $\frac{1}{2}0u$ ;  $\frac{1}{2}0\bar{u}$ ;  $\frac{1}{2}, 0, u+\frac{1}{2}$ ;  $\frac{1}{2}, 0, \frac{1}{2}-u$ .
- (12k)  $\frac{1}{2}0\frac{1}{2}$ ;  $\frac{1}{2}0\frac{3}{2}$ ;  $\frac{3}{2}\frac{1}{2}\frac{1}{2}$ ;  $\frac{3}{2}\frac{3}{2}\frac{1}{2}$ ;  
 $\frac{1}{2}\frac{1}{2}0$ ;  $\frac{3}{2}\frac{1}{2}0$ ;  $\frac{1}{2}\frac{3}{2}\frac{1}{2}$ ;  $\frac{3}{2}\frac{1}{2}\frac{3}{2}$ ;  
 $0\frac{1}{2}\frac{3}{2}$ ;  $0\frac{3}{2}\frac{1}{2}$ ;  $\frac{1}{2}\frac{1}{2}\frac{3}{2}$ ;  $\frac{1}{2}\frac{3}{2}\frac{3}{2}$ ;
- (12l)  $\frac{1}{2}\frac{3}{2}\frac{3}{2}$ ;  $\frac{1}{2}\frac{1}{2}\frac{1}{2}$ ;  $0\frac{3}{2}\frac{3}{2}$ ;  $0\frac{1}{2}\frac{1}{2}$ ;  
 $\frac{3}{2}\frac{1}{2}\frac{1}{2}$ ;  $\frac{1}{2}\frac{3}{2}\frac{1}{2}$ ;  $\frac{3}{2}0\frac{3}{2}$ ;  $\frac{1}{2}\frac{1}{2}0$ ;  
 $\frac{3}{2}\frac{3}{2}\frac{1}{2}$ ;  $\frac{1}{2}\frac{1}{2}\frac{3}{2}$ ;  $\frac{3}{2}\frac{3}{2}0$ ;  $\frac{1}{2}0\frac{1}{2}$ .
- (12m)  $u\bar{u}0$ ;  $u u 0$ ;  $\bar{u}\bar{u}0$ ;  $\bar{u} u 0$ ;  
 $0u\bar{u}$ ;  $0u u$ ;  $0\bar{u}\bar{u}$ ;  $0\bar{u} u$ ;  
 $\bar{u}0u$ ;  $u0u$ ;  $\bar{u}0\bar{u}$ ;  $u0\bar{u}$ .
- (12n)  $u\bar{u}\frac{1}{2}$ ;  $u u \frac{1}{2}$ ;  $\bar{u}\bar{u}\frac{1}{2}$ ;  $\bar{u} u \frac{1}{2}$ ;  
 $\frac{1}{2}u\bar{u}$ ;  $\frac{1}{2}u u$ ;  $\frac{1}{2}\bar{u}\bar{u}$ ;  $\frac{1}{2}\bar{u} u$ ;  
 $\bar{u}\frac{1}{2}u$ ;  $u\frac{1}{2}u$ ;  $\bar{u}\frac{1}{2}\bar{u}$ ;  $u\frac{1}{2}\bar{u}$ .
- (12o)  $u, \frac{1}{2}-u, \frac{1}{2}$ ;  $u, u+\frac{1}{2}, \frac{3}{2}$ ;  $\bar{u}, \frac{1}{2}-u, \frac{3}{2}$ ;  $\bar{u}, u+\frac{1}{2}, \frac{1}{2}$ ;  
 $\frac{1}{2}, u, \frac{1}{2}-u$ ;  $\frac{3}{2}, u, u+\frac{1}{2}$ ;  $\frac{3}{2}, \bar{u}, \frac{1}{2}-u$ ;  $\frac{1}{2}, \bar{u}, u+\frac{1}{2}$ ;  
 $\frac{1}{2}-u, \frac{1}{2}, u$ ;  $u+\frac{1}{2}, \frac{3}{2}, u$ ;  $\frac{1}{2}-u, \frac{3}{2}, \bar{u}$ ;  $u+\frac{1}{2}, \frac{1}{2}, \bar{u}$ .
- (12p)  $u, \frac{1}{2}-u, \frac{3}{2}$ ;  $u, u+\frac{1}{2}, \frac{1}{2}$ ;  $\bar{u}, \frac{1}{2}-u, \frac{1}{2}$ ;  $\bar{u}, u+\frac{1}{2}, \frac{3}{2}$ ;  
 $\frac{3}{2}, u, \frac{1}{2}-u$ ;  $\frac{1}{2}, u, u+\frac{1}{2}$ ;  $\frac{1}{2}, \bar{u}, \frac{1}{2}-u$ ;  $\frac{3}{2}, \bar{u}, u+\frac{1}{2}$ ;  
 $\frac{1}{2}-u, \frac{3}{2}, u$ ;  $u+\frac{1}{2}, \frac{1}{2}, u$ ;  $\frac{1}{2}-u, \frac{1}{2}, \bar{u}$ ;  $u+\frac{1}{2}, \frac{3}{2}, \bar{u}$ .
- (12q)  $\frac{1}{2}-u, u, \frac{1}{2}$ ;  $\frac{3}{2}-u, \frac{1}{2}-u, \frac{7}{2}$ ;  $u+\frac{3}{2}, u+\frac{1}{2}, \frac{3}{2}$ ;  $u+\frac{1}{2}, \bar{u}, \frac{3}{2}$ ;  
 $\frac{1}{2}, \frac{1}{2}-u, u$ ;  $\frac{7}{2}, \frac{3}{2}-u, \frac{1}{2}-u$ ;  $\frac{3}{2}, u+\frac{3}{2}, u+\frac{1}{2}$ ;  $\frac{3}{2}, u+\frac{1}{2}, \bar{u}$ ;  
 $u, \frac{1}{2}, \frac{1}{2}-u$ ;  $\frac{1}{2}-u, \frac{7}{2}, \frac{3}{2}-u$ ;  $u+\frac{1}{2}, \frac{3}{2}, u+\frac{3}{2}$ ;  $\bar{u}, \frac{3}{2}, u+\frac{1}{2}$ .
- (12r)  $\frac{3}{2}-u, u, \frac{3}{2}$ ;  $\frac{1}{2}-u, \frac{1}{2}-u, \frac{3}{2}$ ;  $u+\frac{1}{2}, u+\frac{1}{2}, \frac{1}{2}$ ;  $u+\frac{3}{2}, \bar{u}, \frac{7}{2}$ ;  
 $\frac{3}{2}, \frac{3}{2}-u, u$ ;  $\frac{3}{2}, \frac{1}{2}-u, \frac{1}{2}-u$ ;  $\frac{1}{2}, u+\frac{1}{2}, u+\frac{1}{2}$ ;  $\frac{7}{2}, u+\frac{3}{2}, \bar{u}$ ;  
 $u, \frac{3}{2}, \frac{3}{2}-u$ ;  $\frac{1}{2}-u, \frac{3}{2}, \frac{1}{2}-u$ ;  $u+\frac{1}{2}, \frac{1}{2}, u+\frac{1}{2}$ ;  $\bar{u}, \frac{7}{2}, u+\frac{3}{2}$ .
- (12s)  $\frac{1}{2}0\frac{1}{2}$ ;  $\frac{3}{2}\frac{1}{2}\frac{3}{2}$ ;  $\frac{3}{2}0\frac{3}{2}$ ;  $\frac{1}{2}\frac{7}{2}\frac{1}{2}$ ;  
 $\frac{1}{2}\frac{1}{2}0$ ;  $\frac{3}{2}\frac{3}{2}\frac{1}{2}$ ;  $\frac{3}{2}\frac{3}{2}0$ ;  $\frac{7}{2}\frac{1}{2}\frac{1}{2}$ ;  
 $0\frac{1}{2}\frac{3}{2}$ ;  $\frac{1}{2}\frac{3}{2}\frac{3}{2}$ ;  $0\frac{3}{2}\frac{3}{2}$ ;  $\frac{1}{2}\frac{1}{2}\frac{7}{2}$ .

SIXTEEN EQUIVALENT POSITIONS.

- (16a)  $u u u$ ;  $u+\frac{1}{2}, u+\frac{1}{2}, u$ ;  $u+\frac{1}{2}, u, u+\frac{1}{2}$ ;  $u, u+\frac{1}{2}, u+\frac{1}{2}$ ;  
 $u\bar{u}\bar{u}$ ;  $u+\frac{1}{2}, \frac{1}{2}-u, \bar{u}$ ;  $u+\frac{1}{2}, \bar{u}, \frac{1}{2}-u$ ;  $u, \frac{1}{2}-u, \frac{1}{2}-u$ ;  
 $\bar{u}u\bar{u}$ ;  $\frac{1}{2}-u, u+\frac{1}{2}, \bar{u}$ ;  $\frac{1}{2}-u, u, \frac{1}{2}-u$ ;  $\bar{u}, u+\frac{1}{2}, \frac{1}{2}-u$ ;  
 $\bar{u}\bar{u}u$ ;  $\frac{1}{2}-u, \frac{1}{2}-u, u$ ;  $\frac{1}{2}-u, \bar{u}, u+\frac{1}{2}$ ;  $\bar{u}, \frac{1}{2}-u, u+\frac{1}{2}$ .
- (16b)  $\frac{1}{2}\frac{1}{2}\frac{1}{2}$ ;  $\frac{3}{2}\frac{3}{2}\frac{1}{2}$ ;  $\frac{3}{2}\frac{1}{2}\frac{3}{2}$ ;  $\frac{1}{2}\frac{3}{2}\frac{3}{2}$ ;  
 $\frac{1}{2}\frac{7}{2}\frac{1}{2}$ ;  $\frac{3}{2}\frac{3}{2}\frac{7}{2}$ ;  $\frac{3}{2}\frac{7}{2}\frac{3}{2}$ ;  $\frac{1}{2}\frac{3}{2}\frac{3}{2}$ ;  
 $\frac{7}{2}\frac{1}{2}\frac{7}{2}$ ;  $\frac{3}{2}\frac{3}{2}\frac{7}{2}$ ;  $\frac{3}{2}\frac{1}{2}\frac{3}{2}$ ;  $\frac{7}{2}\frac{3}{2}\frac{3}{2}$ ;  
 $\frac{7}{2}\frac{7}{2}\frac{1}{2}$ ;  $\frac{3}{2}\frac{3}{2}\frac{1}{2}$ ;  $\frac{3}{2}\frac{7}{2}\frac{3}{2}$ ;  $\frac{7}{2}\frac{3}{2}\frac{3}{2}$ .

## SIXTEEN EQUIVALENT POSITIONS.—Continued.

- (16c)  $\frac{1}{2}\frac{1}{2}\frac{1}{2}$ ;  $\frac{1}{2}\frac{1}{2}\frac{1}{2}$ ;  $\frac{1}{2}\frac{1}{2}\frac{1}{2}$ ;  $\frac{1}{2}\frac{1}{2}\frac{1}{2}$ ;  
 $\frac{1}{2}\frac{1}{2}\frac{1}{2}$ ;  $\frac{1}{2}\frac{1}{2}\frac{1}{2}$ ;  $\frac{1}{2}\frac{1}{2}\frac{1}{2}$ ;  $\frac{1}{2}\frac{1}{2}\frac{1}{2}$ ;  
 $\frac{1}{2}\frac{1}{2}\frac{1}{2}$ ;  $\frac{1}{2}\frac{1}{2}\frac{1}{2}$ ;  $\frac{1}{2}\frac{1}{2}\frac{1}{2}$ ;  $\frac{1}{2}\frac{1}{2}\frac{1}{2}$ ;  
 $\frac{1}{2}\frac{1}{2}\frac{1}{2}$ ;  $\frac{1}{2}\frac{1}{2}\frac{1}{2}$ ;  $\frac{1}{2}\frac{1}{2}\frac{1}{2}$ ;  $\frac{1}{2}\frac{1}{2}\frac{1}{2}$ .
- (16d)  $u u u$ ;  $\bar{u} \bar{u} \bar{u}$ ;  $u + \frac{1}{2}$ ,  $u + \frac{1}{2}$ ,  $u + \frac{1}{2}$ ;  $\frac{1}{2} - u$ ,  $\frac{1}{2} - u$ ,  $\frac{1}{2} - u$ ;  
 $u \bar{u} \bar{u}$ ;  $\bar{u} u u$ ;  $u + \frac{1}{2}$ ,  $\frac{1}{2} - u$ ,  $\frac{1}{2} - u$ ;  $\frac{1}{2} - u$ ,  $u + \frac{1}{2}$ ,  $u + \frac{1}{2}$ ;  
 $\bar{u} u \bar{u}$ ;  $u \bar{u} u$ ;  $\frac{1}{2} - u$ ,  $u + \frac{1}{2}$ ,  $\frac{1}{2} - u$ ;  $u + \frac{1}{2}$ ,  $\frac{1}{2} - u$ ,  $u + \frac{1}{2}$ ;  
 $\bar{u} \bar{u} u$ ;  $u u \bar{u}$ ;  $\frac{1}{2} - u$ ,  $\frac{1}{2} - u$ ,  $u + \frac{1}{2}$ ;  $u + \frac{1}{2}$ ,  $u + \frac{1}{2}$ ,  $\frac{1}{2} - u$ .
- (16e)  $u u u$ ;  $u$ ,  $\bar{u}$ ,  $\frac{1}{2} - u$ ;  $\frac{1}{2} - u$ ,  $u$ ,  $\bar{u}$ ;  $\bar{u}$ ,  $\frac{1}{2} - u$ ,  $u$ ;  
 $\bar{u} \bar{u} \bar{u}$ ;  $\bar{u}$ ,  $u$ ,  $u + \frac{1}{2}$ ;  $u + \frac{1}{2}$ ,  $\bar{u}$ ,  $u$ ;  $u$ ,  $u + \frac{1}{2}$ ,  $\bar{u}$ ;  
 $u + \frac{1}{2}$ ,  $u + \frac{1}{2}$ ,  $u + \frac{1}{2}$ ;  $u + \frac{1}{2}$ ,  $\frac{1}{2} - u$ ,  $\bar{u}$ ;  $\bar{u}$ ,  $u + \frac{1}{2}$ ,  $\frac{1}{2} - u$ ;  
 $\frac{1}{2} - u$ ,  $\bar{u}$ ,  $u + \frac{1}{2}$ ;  
 $u - \frac{1}{2}$ ,  $u - \frac{1}{2}$ ,  $u - \frac{1}{2}$ ;  $\frac{1}{2} - u$ ,  $u + \frac{1}{2}$ ,  $u$ ;  $u$ ,  $\frac{1}{2} - u$ ,  $u + \frac{1}{2}$ ;  
 $u + \frac{1}{2}$ ,  $u$ ,  $\frac{1}{2} - u$ .
- (16f)  $u u u$ ;  $u$ ,  $\bar{u}$ ,  $\frac{1}{2} - u$ ;  $\frac{1}{2} - u$ ,  $u$ ,  $\bar{u}$ ;  $\bar{u}$ ,  $\frac{1}{2} - u$ ,  $u$ ;  
 $u + \frac{1}{2}$ ,  $u + \frac{1}{2}$ ,  $u + \frac{1}{2}$ ;  $\frac{1}{2} - u$ ,  $u + \frac{1}{2}$ ,  $\frac{1}{2} - u$ ;  $u + \frac{1}{2}$ ,  $\frac{1}{2} - u$ ,  $\frac{1}{2} - u$ ;  
 $\frac{1}{2} - u$ ,  $\frac{1}{2} - u$ ,  $u + \frac{1}{2}$ ;  
 $u + \frac{1}{2}$ ,  $u + \frac{1}{2}$ ,  $u + \frac{1}{2}$ ;  $u + \frac{1}{2}$ ,  $\frac{1}{2} - u$ ,  $\bar{u}$ ;  $\bar{u}$ ,  $u + \frac{1}{2}$ ,  $\frac{1}{2} - u$ ;  
 $\frac{1}{2} - u$ ,  $\bar{u}$ ,  $u + \frac{1}{2}$ ;  
 $u + \frac{1}{2}$ ,  $u + \frac{1}{2}$ ,  $u + \frac{1}{2}$ ;  $\frac{1}{2} - u$ ,  $u + \frac{1}{2}$ ,  $\frac{1}{2} - u$ ;  $u + \frac{1}{2}$ ,  $\frac{1}{2} - u$ ,  $\frac{1}{2} - u$ ;  
 $\frac{1}{2} - u$ ,  $\frac{1}{2} - u$ ,  $u + \frac{1}{2}$ .
- (16g)  $u u u$ ;  $u$ ,  $\bar{u}$ ,  $\frac{1}{2} - u$ ;  $\frac{1}{2} - u$ ,  $u$ ,  $\bar{u}$ ;  $\bar{u}$ ,  $\frac{1}{2} - u$ ,  $u$ ;  
 $\frac{1}{2} - u$ ,  $\frac{1}{2} - u$ ,  $\frac{1}{2} - u$ ;  $u + \frac{1}{2}$ ,  $\frac{1}{2} - u$ ,  $u + \frac{1}{2}$ ;  $\frac{1}{2} - u$ ,  $u + \frac{1}{2}$ ,  $u + \frac{1}{2}$ ;  
 $u + \frac{1}{2}$ ,  $u + \frac{1}{2}$ ,  $\frac{1}{2} - u$ ;  $u + \frac{1}{2}$ ,  $\frac{1}{2} - u$ ,  $\bar{u}$ ;  $\bar{u}$ ,  $u + \frac{1}{2}$ ,  $\frac{1}{2} - u$ ;  
 $\frac{1}{2} - u$ ,  $\bar{u}$ ,  $u + \frac{1}{2}$ ;  
 $\frac{1}{2} - u$ ,  $\frac{1}{2} - u$ ,  $\frac{1}{2} - u$ ;  $u + \frac{1}{2}$ ,  $\frac{1}{2} - u$ ,  $u + \frac{1}{2}$ ;  $\frac{1}{2} - u$ ,  $u + \frac{1}{2}$ ,  $u + \frac{1}{2}$ ;  
 $u + \frac{1}{2}$ ,  $u + \frac{1}{2}$ ,  $\frac{1}{2} - u$ .
- (16h)  $0 0 0$ ;  $\frac{1}{2}\frac{1}{2}\frac{1}{2}$ ;  $\frac{1}{2}\frac{1}{2}\frac{1}{2}$ ;  $\frac{1}{2}\frac{1}{2}\frac{1}{2}$ ;  
 $\frac{1}{2}\frac{1}{2} 0$ ;  $\frac{1}{2}\frac{1}{2}\frac{1}{2}$ ;  $\frac{1}{2}\frac{1}{2}\frac{1}{2}$ ;  $0 0 \frac{1}{2}$ ;  
 $\frac{1}{2} 0 \frac{1}{2}$ ;  $\frac{1}{2}\frac{1}{2}\frac{1}{2}$ ;  $\frac{1}{2}\frac{1}{2}\frac{1}{2}$ ;  $0 \frac{1}{2} 0$ ;  
 $0 \frac{1}{2} \frac{1}{2}$ ;  $\frac{1}{2}\frac{1}{2}\frac{1}{2}$ ;  $\frac{1}{2}\frac{1}{2}\frac{1}{2}$ ;  $\frac{1}{2} 0 0$ .
- (16i)  $\frac{1}{2}\frac{1}{2}\frac{1}{2}$ ;  $\frac{1}{2}\frac{1}{2}\frac{1}{2}$ ;  $\frac{1}{2}\frac{1}{2}\frac{1}{2}$ ;  $\frac{1}{2}\frac{1}{2}\frac{1}{2}$ ;  
 $\frac{1}{2}\frac{1}{2}\frac{1}{2}$ ;  $\frac{1}{2}\frac{1}{2}\frac{1}{2}$ ;  $\frac{1}{2}\frac{1}{2}\frac{1}{2}$ ;  $\frac{1}{2}\frac{1}{2}\frac{1}{2}$ ;  
 $\frac{1}{2}\frac{1}{2}\frac{1}{2}$ ;  $\frac{1}{2}\frac{1}{2}\frac{1}{2}$ ;  $\frac{1}{2}\frac{1}{2}\frac{1}{2}$ ;  $\frac{1}{2}\frac{1}{2}\frac{1}{2}$ ;  
 $\frac{1}{2}\frac{1}{2}\frac{1}{2}$ ;  $\frac{1}{2}\frac{1}{2}\frac{1}{2}$ ;  $\frac{1}{2}\frac{1}{2}\frac{1}{2}$ ;  $\frac{1}{2}\frac{1}{2}\frac{1}{2}$ .

## TWENTY-FOUR EQUIVALENT POSITIONS.

- (24a)  $u 0 0$ ;  $u + \frac{1}{2}$ ,  $\frac{1}{2}$ ,  $0$ ;  $u + \frac{1}{2}$ ,  $0$ ,  $\frac{1}{2}$ ;  $u \frac{1}{2} \frac{1}{2}$ ;  
 $\bar{u} 0 0$ ;  $\frac{1}{2} - u$ ,  $\frac{1}{2}$ ,  $0$ ;  $\frac{1}{2} - u$ ,  $0$ ,  $\frac{1}{2}$ ;  $\bar{u} \frac{1}{2} \frac{1}{2}$ ;  
 $0 u 0$ ;  $\frac{1}{2}$ ,  $u + \frac{1}{2}$ ,  $0$ ;  $\frac{1}{2} u \frac{1}{2}$ ;  $0$ ,  $u + \frac{1}{2}$ ,  $\frac{1}{2}$ ;  
 $0 \bar{u} 0$ ;  $\frac{1}{2}$ ,  $\frac{1}{2} - u$ ,  $0$ ;  $\frac{1}{2} \bar{u} \frac{1}{2}$ ;  $0$ ,  $\frac{1}{2} - u$ ,  $\frac{1}{2}$ ;  
 $0 0 u$ ;  $\frac{1}{2} \frac{1}{2} u$ ;  $\frac{1}{2}$ ,  $0$ ,  $u + \frac{1}{2}$ ;  $0$ ,  $\frac{1}{2}$ ,  $u + \frac{1}{2}$ ;  
 $0 0 \bar{u}$ ;  $\frac{1}{2} \frac{1}{2} \bar{u}$ ;  $\frac{1}{2}$ ,  $0$ ,  $\frac{1}{2} - u$ ;  $0$ ,  $\frac{1}{2}$ ,  $\frac{1}{2} - u$ .

TWENTY-FOUR EQUIVALENT POSITIONS.—Continued.

- (24b)  $\frac{1}{2} \frac{1}{2} u$ ;  $\bar{u} \frac{1}{2} \frac{1}{2}$ ;  $u + \frac{1}{2}, \frac{1}{2}, \frac{1}{2}$ ;  $\frac{1}{2}, \frac{1}{2} - u, \frac{1}{2}$ ;  
 $\frac{1}{2} \frac{1}{2} \bar{u}$ ;  $u \frac{1}{2} \frac{1}{2}$ ;  $\frac{1}{2} - u, \frac{1}{2}, \frac{1}{2}$ ;  $\frac{1}{2}, u + \frac{1}{2}, \frac{1}{2}$ ;  
 $\frac{1}{2} \frac{1}{2} \bar{u}$ ;  $\frac{1}{2} u \frac{1}{2}$ ;  $\frac{1}{2} - u, \frac{1}{2}, \frac{1}{2}$ ;  $\frac{1}{2}, \frac{1}{2}, u + \frac{1}{2}$ ;  
 $\frac{1}{2} \frac{1}{2} u$ ;  $\frac{1}{2} \bar{u} \frac{1}{2}$ ;  $u + \frac{1}{2}, \frac{1}{2}, \frac{1}{2}$ ;  $\frac{1}{2}, \frac{1}{2}, \frac{1}{2} - u$ ;  
 $u \frac{1}{2} \frac{1}{2}$ ;  $\frac{1}{2} \bar{u} \frac{1}{2}$ ;  $\frac{1}{2}, u + \frac{1}{2}, \frac{1}{2}$ ;  $\frac{1}{2}, \frac{1}{2}, \frac{1}{2} - u$ ;  
 $\bar{u} \frac{1}{2} \frac{1}{2}$ ;  $\frac{1}{2} u \frac{1}{2}$ ;  $\frac{1}{2}, \frac{1}{2} - u, \frac{1}{2}$ ;  $\frac{1}{2}, \frac{1}{2}, u + \frac{1}{2}$ .
- (24c)  $\frac{1}{2} \frac{1}{2} 0$ ;  $\frac{1}{2} \frac{1}{2} 0$ ;  $\frac{1}{2} \frac{1}{2} 0$ ;  $\frac{1}{2} \frac{1}{2} 0$ ;  
 $0 \frac{1}{2} \frac{1}{2}$ ;  $0 \frac{1}{2} \frac{1}{2}$ ;  $0 \frac{1}{2} \frac{1}{2}$ ;  $0 \frac{1}{2} \frac{1}{2}$ ;  
 $\frac{1}{2} 0 \frac{1}{2}$ ;  $\frac{1}{2} 0 \frac{1}{2}$ ;  $\frac{1}{2} 0 \frac{1}{2}$ ;  $\frac{1}{2} 0 \frac{1}{2}$ ;  
 $\frac{1}{2} \frac{1}{2} \frac{1}{2}$ ;  $\frac{1}{2} \frac{1}{2} \frac{1}{2}$ ;  $\frac{1}{2} \frac{1}{2} \frac{1}{2}$ ;  $\frac{1}{2} \frac{1}{2} \frac{1}{2}$ ;  
 $\frac{1}{2} \frac{1}{2} \frac{1}{2}$ ;  $\frac{1}{2} \frac{1}{2} \frac{1}{2}$ ;  $\frac{1}{2} \frac{1}{2} \frac{1}{2}$ ;  $\frac{1}{2} \frac{1}{2} \frac{1}{2}$ ;  
 $\frac{1}{2} \frac{1}{2} \frac{1}{2}$ ;  $\frac{1}{2} \frac{1}{2} \frac{1}{2}$ ;  $\frac{1}{2} \frac{1}{2} \frac{1}{2}$ ;  $\frac{1}{2} \frac{1}{2} \frac{1}{2}$ .
- (24d)  $0 u v$ ;  $\bar{v} 0 u$ ;  $\frac{1}{2}, u + \frac{1}{2}, v + \frac{1}{2}$ ;  $\frac{1}{2} - v, \frac{1}{2}, u + \frac{1}{2}$ ;  
 $0 \bar{u} \bar{v}$ ;  $v 0 \bar{u}$ ;  $\frac{1}{2}, \frac{1}{2} - u, \frac{1}{2} - v$ ;  $v + \frac{1}{2}, \frac{1}{2}, \frac{1}{2} - u$ ;  
 $0 u \bar{v}$ ;  $u v 0$ ;  $\frac{1}{2}, u + \frac{1}{2}, \frac{1}{2} - v$ ;  $u + \frac{1}{2}, v + \frac{1}{2}, \frac{1}{2}$ ;  
 $0 \bar{u} v$ ;  $\bar{u} \bar{v} 0$ ;  $\frac{1}{2}, \frac{1}{2} - u, v + \frac{1}{2}$ ;  $\frac{1}{2} - u, \frac{1}{2} - v, \frac{1}{2}$ ;  
 $v 0 u$ ;  $u \bar{v} 0$ ;  $v + \frac{1}{2}, \frac{1}{2}, u + \frac{1}{2}$ ;  $u + \frac{1}{2}, \frac{1}{2} - v, \frac{1}{2}$ ;  
 $\bar{v} 0 \bar{u}$ ;  $\bar{u} v 0$ ;  $\frac{1}{2} - v, \frac{1}{2}, \frac{1}{2} - u$ ;  $\frac{1}{2} - u, v + \frac{1}{2}, \frac{1}{2}$ .
- (24e)  $u 0 \frac{1}{2}$ ;  $\bar{u} \frac{1}{2} \frac{1}{2}$ ;  $\frac{1}{2} - u, 0, \frac{1}{2}$ ;  $u + \frac{1}{2}, \frac{1}{2}, \frac{1}{2}$ ;  
 $\frac{1}{2} u 0$ ;  $\frac{1}{2} \bar{u} \frac{1}{2}$ ;  $\frac{1}{2}, \frac{1}{2} - u, 0$ ;  $\frac{1}{2}, u + \frac{1}{2}, \frac{1}{2}$ ;  
 $0 \frac{1}{2} u$ ;  $\frac{1}{2} \frac{1}{2} \bar{u}$ ;  $0, \frac{1}{2}, \frac{1}{2} - u$ ;  $\frac{1}{2}, \frac{1}{2}, u + \frac{1}{2}$ ;  
 $\bar{u} 0 \frac{1}{2}$ ;  $u \frac{1}{2} \frac{1}{2}$ ;  $u + \frac{1}{2}, 0, \frac{1}{2}$ ;  $\frac{1}{2} - u, \frac{1}{2}, \frac{1}{2}$ ;  
 $\frac{1}{2} \bar{u} 0$ ;  $\frac{1}{2} u \frac{1}{2}$ ;  $\frac{1}{2}, u + \frac{1}{2}, 0$ ;  $\frac{1}{2}, \frac{1}{2} - u, \frac{1}{2}$ ;  
 $0 \frac{1}{2} \bar{u}$ ;  $\frac{1}{2} \frac{1}{2} u$ ;  $0, \frac{1}{2}, u + \frac{1}{2}$ ;  $\frac{1}{2}, \frac{1}{2}, \frac{1}{2} - u$ .
- (24f)  $u 0 \frac{1}{2}$ ;  $u \frac{1}{2} 0$ ;  $u + \frac{1}{2}, \frac{1}{2}, 0$ ;  $u + \frac{1}{2}, 0, \frac{1}{2}$ ;  
 $\frac{1}{2} u 0$ ;  $0 u \frac{1}{2}$ ;  $0, u + \frac{1}{2}, \frac{1}{2}$ ;  $\frac{1}{2}, u + \frac{1}{2}, 0$ ;  
 $0 \frac{1}{2} u$ ;  $\frac{1}{2} 0 u$ ;  $\frac{1}{2}, 0, u + \frac{1}{2}$ ;  $0, \frac{1}{2}, u + \frac{1}{2}$ ;  
 $\bar{u} 0 \frac{1}{2}$ ;  $\bar{u} \frac{1}{2} 0$ ;  $\frac{1}{2} - u, \frac{1}{2}, 0$ ;  $\frac{1}{2} - u, 0, \frac{1}{2}$ ;  
 $\frac{1}{2} \bar{u} 0$ ;  $0 \bar{u} \frac{1}{2}$ ;  $0, \frac{1}{2} - u, \frac{1}{2}$ ;  $\frac{1}{2}, \frac{1}{2} - u, 0$ ;  
 $0 \frac{1}{2} \bar{u}$ ;  $\frac{1}{2} 0 \bar{u}$ ;  $\frac{1}{2}, 0, \frac{1}{2} - u$ ;  $0, \frac{1}{2}, \frac{1}{2} - u$ .
- (24g)  $u u v$ ;  $\bar{u} u \bar{v}$ ;  $u + \frac{1}{2}, u + \frac{1}{2}, v + \frac{1}{2}$ ;  $\frac{1}{2} - u, u + \frac{1}{2}, \frac{1}{2} - v$ ;  
 $v u u$ ;  $\bar{v} \bar{u} u$ ;  $v + \frac{1}{2}, u + \frac{1}{2}, u + \frac{1}{2}$ ;  $\frac{1}{2} - v, \frac{1}{2} - u, u + \frac{1}{2}$ ;  
 $u v u$ ;  $u \bar{v} \bar{u}$ ;  $u + \frac{1}{2}, v + \frac{1}{2}, u + \frac{1}{2}$ ;  $u + \frac{1}{2}, \frac{1}{2} - v, \frac{1}{2} - u$ ;  
 $u \bar{u} \bar{v}$ ;  $\bar{u} \bar{u} v$ ;  $u + \frac{1}{2}, \frac{1}{2} - u, \frac{1}{2} - v$ ;  $\frac{1}{2} - u, \frac{1}{2} - u, v + \frac{1}{2}$ ;  
 $\bar{v} u \bar{u}$ ;  $v \bar{u} \bar{u}$ ;  $\frac{1}{2} - v, u + \frac{1}{2}, \frac{1}{2} - u$ ;  $v + \frac{1}{2}, \frac{1}{2} - u, \frac{1}{2} - u$ ;  
 $\bar{u} \bar{v} u$ ;  $\bar{u} v \bar{u}$ ;  $\frac{1}{2} - u, \frac{1}{2} - v, u + \frac{1}{2}$ ;  $\frac{1}{2} - u, v + \frac{1}{2}, \frac{1}{2} - u$ .
- (24h)  $\frac{1}{2} 0 0$ ;  $\frac{1}{2} \frac{1}{2} \frac{1}{2}$ ;  $\frac{1}{2} \frac{1}{2} 0$ ;  $0 \frac{1}{2} \frac{1}{2}$ ;  
 $0 \frac{1}{2} 0$ ;  $\frac{1}{2} \frac{1}{2} \frac{1}{2}$ ;  $\frac{1}{2} \frac{1}{2} 0$ ;  $\frac{1}{2} 0 \frac{1}{2}$ ;  
 $0 0 \frac{1}{2}$ ;  $\frac{1}{2} \frac{1}{2} \frac{1}{2}$ ;  $\frac{1}{2} \frac{1}{2} 0$ ;  $\frac{1}{2} 0 \frac{1}{2}$ ;  
 $\frac{1}{2} 0 0$ ;  $\frac{1}{2} \frac{1}{2} \frac{1}{2}$ ;  $\frac{1}{2} \frac{1}{2} 0$ ;  $\frac{1}{2} 0 \frac{1}{2}$ ;  
 $0 \frac{1}{2} 0$ ;  $\frac{1}{2} \frac{1}{2} \frac{1}{2}$ ;  $0 \frac{1}{2} \frac{1}{2}$ ;  $0 \frac{1}{2} \frac{1}{2}$ ;  
 $0 0 \frac{1}{2}$ ;  $\frac{1}{2} \frac{1}{2} \frac{1}{2}$ ;  $\frac{1}{2} 0 \frac{1}{2}$ ;  $0 \frac{1}{2} \frac{1}{2}$ .



TWENTY-FOUR EQUIVALENT POSITIONS.—Continued.

- (24i)  $u0\frac{1}{2}$ ;  $\frac{1}{2}-u, 0, \frac{1}{2}$ ;  $\bar{u}\frac{1}{2}\frac{1}{2}$ ;  $\frac{1}{2}, \frac{1}{2}-u, 0$ ;  
 $\frac{1}{2}u0$ ;  $\frac{1}{2}, \frac{1}{2}-u, 0$ ;  $\frac{1}{2}\bar{u}\frac{1}{2}$ ;  $\frac{1}{2}-u, 0, \frac{1}{2}$ ;  
 $0\frac{1}{2}u$ ;  $0, \frac{1}{2}, \frac{1}{2}-u$ ;  $\frac{1}{2}\frac{1}{2}\bar{u}$ ;  $0, \frac{1}{2}, \frac{1}{2}-u$ ;  
 $\frac{1}{2}, u+\frac{1}{2}, \frac{1}{2}$ ;  $\frac{1}{2}, \frac{1}{2}-u, \frac{1}{2}$ ;  $u+\frac{1}{2}, \frac{1}{2}, \frac{1}{2}$ ;  $\frac{1}{2}, u+\frac{1}{2}, 0$ ;  
 $u+\frac{1}{2}, \frac{1}{2}, \frac{1}{2}$ ;  $\frac{1}{2}-u, \frac{1}{2}, \frac{1}{2}$ ;  $\frac{1}{2}, u+\frac{1}{2}, \frac{1}{2}$ ;  $u+\frac{1}{2}, 0, \frac{1}{2}$ ;  
 $\frac{1}{2}, \frac{1}{2}, u+\frac{1}{2}$ ;  $\frac{1}{2}, \frac{1}{2}, \frac{1}{2}-u$ ;  $\frac{1}{2}, \frac{1}{2}, u+\frac{1}{2}$ ;  $0, \frac{1}{2}, u+\frac{1}{2}$ .
- (24j)  $u\bar{u}0$ ;  $uu0$ ;  $u+\frac{1}{2}, \frac{1}{2}-u, \frac{1}{2}$ ;  $\frac{1}{2}-u, \frac{1}{2}-u, \frac{1}{2}$ ;  
 $0u\bar{u}$ ;  $0uu$ ;  $\frac{1}{2}, u+\frac{1}{2}, \frac{1}{2}-u$ ;  $\frac{1}{2}, \frac{1}{2}-u, \frac{1}{2}-u$ ;  
 $\bar{u}0u$ ;  $u0u$ ;  $\frac{1}{2}-u, \frac{1}{2}, u+\frac{1}{2}$ ;  $\frac{1}{2}-u, \frac{1}{2}, \frac{1}{2}-u$ ;  
 $\bar{u}u0$ ;  $\bar{u}\bar{u}0$ ;  $u+\frac{1}{2}, u+\frac{1}{2}, \frac{1}{2}$ ;  $\frac{1}{2}-u, u+\frac{1}{2}, \frac{1}{2}$ ;  
 $0\bar{u}u$ ;  $0\bar{u}\bar{u}$ ;  $\frac{1}{2}, u+\frac{1}{2}, u+\frac{1}{2}$ ;  $\frac{1}{2}, \frac{1}{2}-u, u+\frac{1}{2}$ ;  
 $u0\bar{u}$ ;  $\bar{u}0\bar{u}$ ;  $u+\frac{1}{2}, \frac{1}{2}, u+\frac{1}{2}$ ;  $u+\frac{1}{2}, \frac{1}{2}, \frac{1}{2}-u$ .
- (24k)  $u, \frac{1}{2}-u, \frac{1}{2}$ ;  $u, u+\frac{1}{2}, \frac{1}{2}$ ;  $\bar{u}, \frac{1}{2}-u, \frac{1}{2}$ ;  $\bar{u}, u+\frac{1}{2}, \frac{1}{2}$ ;  
 $\frac{1}{2}, u, \frac{1}{2}-u$ ;  $\frac{1}{2}, u, u+\frac{1}{2}$ ;  $\frac{1}{2}, \bar{u}, \frac{1}{2}-u$ ;  $\frac{1}{2}, \bar{u}, u+\frac{1}{2}$ ;  
 $\frac{1}{2}-u, \frac{1}{2}, u$ ;  $u+\frac{1}{2}, \frac{1}{2}, u$ ;  $\frac{1}{2}-u, \frac{1}{2}, \bar{u}$ ;  $u+\frac{1}{2}, \frac{1}{2}, \bar{u}$ ;  
 $u+\frac{1}{2}, \bar{u}, \frac{1}{2}$ ;  $\frac{1}{2}-u, \bar{u}, \frac{1}{2}$ ;  $u+\frac{1}{2}, u, \frac{1}{2}$ ;  $\frac{1}{2}-u, u, \frac{1}{2}$ ;  
 $\bar{u}, \frac{1}{2}, u+\frac{1}{2}$ ;  $\bar{u}, \frac{1}{2}, \frac{1}{2}-u$ ;  $u, \frac{1}{2}, u+\frac{1}{2}$ ;  $u, \frac{1}{2}, \frac{1}{2}-u$ ;  
 $\frac{1}{2}, u+\frac{1}{2}, \bar{u}$ ;  $\frac{1}{2}, \frac{1}{2}-u, \bar{u}$ ;  $\frac{1}{2}, u+\frac{1}{2}, u$ ;  $\frac{1}{2}, \frac{1}{2}-u, u$ .
- (24l)  $u0\frac{1}{2}$ ;  $u+\frac{1}{2}, \frac{1}{2}, \frac{1}{2}$ ;  $\frac{1}{2}-u, 0, \frac{1}{2}$ ;  $\bar{u}\frac{1}{2}\frac{1}{2}$ ;  
 $\frac{1}{2}u0$ ;  $\frac{1}{2}, u+\frac{1}{2}, \frac{1}{2}$ ;  $\frac{1}{2}, \frac{1}{2}-u, 0$ ;  $\frac{1}{2}\bar{u}\frac{1}{2}$ ;  
 $0\frac{1}{2}u$ ;  $\frac{1}{2}, \frac{1}{2}, u+\frac{1}{2}$ ;  $0, \frac{1}{2}, \frac{1}{2}-u$ ;  $\frac{1}{2}\frac{1}{2}\bar{u}$ ;  
 $\frac{1}{2}, \frac{1}{2}-u, 0$ ;  $\frac{1}{2}, \frac{1}{2}-u, \frac{1}{2}$ ;  $\frac{1}{2}, u+\frac{1}{2}, \frac{1}{2}$ ;  $\frac{1}{2}, u+\frac{1}{2}, 0$ ;  
 $\frac{1}{2}-u, 0, \frac{1}{2}$ ;  $\frac{1}{2}-u, \frac{1}{2}, \frac{1}{2}$ ;  $u+\frac{1}{2}, \frac{1}{2}, \frac{1}{2}$ ;  $u+\frac{1}{2}, 0, \frac{1}{2}$ ;  
 $0, \frac{1}{2}, \frac{1}{2}-u$ ;  $\frac{1}{2}, \frac{1}{2}, \frac{1}{2}-u$ ;  $\frac{1}{2}, \frac{1}{2}, u+\frac{1}{2}$ ;  $0, \frac{1}{2}, u+\frac{1}{2}$ .
- (24m)  $u, u+\frac{1}{2}, \frac{1}{2}$ ;  $\bar{u}, \frac{1}{2}-u, \frac{1}{2}$ ;  $u, \frac{1}{2}-u, \frac{1}{2}$ ;  $\bar{u}, u+\frac{1}{2}, \frac{1}{2}$ ;  
 $\frac{1}{2}, u, u+\frac{1}{2}$ ;  $\frac{1}{2}, \bar{u}, \frac{1}{2}-u$ ;  $\frac{1}{2}, u, \frac{1}{2}-u$ ;  $\frac{1}{2}, \bar{u}, u+\frac{1}{2}$ ;  
 $u+\frac{1}{2}, \frac{1}{2}, u$ ;  $\frac{1}{2}-u, \frac{1}{2}, \bar{u}$ ;  $\frac{1}{2}-u, \frac{1}{2}, u$ ;  $u+\frac{1}{2}, \frac{1}{2}, \bar{u}$ ;  
 $u+\frac{1}{2}, \frac{1}{2}-u, \frac{1}{2}$ ;  $\frac{1}{2}-u, u+\frac{1}{2}, \frac{1}{2}$ ;  $u+\frac{1}{2}, u+\frac{1}{2}, \frac{1}{2}$ ;  
 $\frac{1}{2}-u, \frac{1}{2}-u, \frac{1}{2}$ ;  
 $\frac{1}{2}, u+\frac{1}{2}, \frac{1}{2}-u$ ;  $\frac{1}{2}, \frac{1}{2}-u, u+\frac{1}{2}$ ;  $\frac{1}{2}, u+\frac{1}{2}, u+\frac{1}{2}$ ;  
 $\frac{1}{2}, \frac{1}{2}-u, \frac{1}{2}-u$ ;  
 $\frac{1}{2}-u, \frac{1}{2}, u+\frac{1}{2}$ ;  $u+\frac{1}{2}, \frac{1}{2}, \frac{1}{2}-u$ ;  $u+\frac{1}{2}, \frac{1}{2}, u+\frac{1}{2}$ ;  
 $\frac{1}{2}-u, \frac{1}{2}, \frac{1}{2}-u$ .
- (24n)  $u, \frac{1}{2}-u, \frac{1}{2}$ ;  $\bar{u}, u+\frac{1}{2}, \frac{1}{2}$ ;  $u, u+\frac{1}{2}, \frac{1}{2}$ ;  $\bar{u}, \frac{1}{2}-u, \frac{1}{2}$ ;  
 $\frac{1}{2}, u, \frac{1}{2}-u$ ;  $\frac{1}{2}, \bar{u}, u+\frac{1}{2}$ ;  $\frac{1}{2}, u, u+\frac{1}{2}$ ;  $\frac{1}{2}, \bar{u}, \frac{1}{2}-u$ ;  
 $\frac{1}{2}-u, \frac{1}{2}, u$ ;  $u+\frac{1}{2}, \frac{1}{2}, \bar{u}$ ;  $u+\frac{1}{2}, \frac{1}{2}, u$ ;  $\frac{1}{2}-u, \frac{1}{2}, \bar{u}$ ;  
 $u+\frac{1}{2}, u+\frac{1}{2}, \frac{1}{2}$ ;  $\frac{1}{2}-u, \frac{1}{2}-u, \frac{1}{2}$ ;  $u+\frac{1}{2}, \frac{1}{2}-u, \frac{1}{2}$ ;  
 $\frac{1}{2}-u, u+\frac{1}{2}, \frac{1}{2}$ ;  
 $\frac{1}{2}, u+\frac{1}{2}, u+\frac{1}{2}$ ;  $\frac{1}{2}, \frac{1}{2}-u, \frac{1}{2}-u$ ;  $\frac{1}{2}, u+\frac{1}{2}, \frac{1}{2}-u$ ;  
 $\frac{1}{2}, \frac{1}{2}-u, u+\frac{1}{2}$ ;  
 $u+\frac{1}{2}, \frac{1}{2}, u+\frac{1}{2}$ ;  $\frac{1}{2}-u, \frac{1}{2}, \frac{1}{2}-u$ ;  $\frac{1}{2}-u, \frac{1}{2}, u+\frac{1}{2}$ ;  
 $u+\frac{1}{2}, \frac{1}{2}, \frac{1}{2}-u$ .

TWENTY-FOUR EQUIVALENT POSITIONS.—Continued.

- (24o)  $0uv; 0\bar{u}\bar{v}; 0u\bar{v}; 0\bar{u}v;$   
 $v0u; \bar{v}0\bar{u}; \bar{v}0u; v0\bar{u};$   
 $uv0; \bar{u}\bar{v}0; u\bar{v}0; \bar{u}v0;$   
 $u0v; \bar{u}0\bar{v}; u0\bar{v}; \bar{u}0v;$   
 $0vu; 0\bar{v}\bar{u}; 0\bar{v}u; 0v\bar{u};$   
 $v\bar{u}0; \bar{v}\bar{u}0; \bar{v}u0; v\bar{u}0;$
- (24p)  $\frac{1}{2}uv; \frac{1}{2}\bar{u}\bar{v}; \frac{1}{2}u\bar{v}; \frac{1}{2}\bar{u}v;$   
 $v\frac{1}{2}u; \bar{v}\frac{1}{2}\bar{u}; \bar{v}\frac{1}{2}u; v\frac{1}{2}\bar{u};$   
 $uv\frac{1}{2}; \bar{u}\bar{v}\frac{1}{2}; u\bar{v}\frac{1}{2}; \bar{u}v\frac{1}{2};$   
 $u\frac{1}{2}v; \bar{u}\frac{1}{2}\bar{v}; u\frac{1}{2}\bar{v}; \bar{u}\frac{1}{2}v;$   
 $\frac{1}{2}vu; \frac{1}{2}\bar{v}\bar{u}; \frac{1}{2}\bar{v}u; \frac{1}{2}v\bar{u};$   
 $v\bar{u}\frac{1}{2}; \bar{v}\bar{u}\frac{1}{2}; \bar{v}u\frac{1}{2}; v\bar{u}\frac{1}{2}.$
- (24q)  $uu\bar{v}; u\bar{u}\bar{v}; \bar{u}u\bar{v}; \bar{u}\bar{u}v;$   
 $vuu; \bar{v}u\bar{u}; \bar{v}\bar{u}u; v\bar{u}\bar{u};$   
 $uvu; \bar{u}\bar{v}u; u\bar{v}\bar{u}; \bar{u}v\bar{u};$   
 $\bar{u}\bar{u}\bar{v}; \bar{u}uv; u\bar{u}v; uu\bar{v};$   
 $\bar{v}\bar{u}\bar{u}; v\bar{u}u; v\bar{u}\bar{u}; \bar{v}uu;$   
 $\bar{u}\bar{v}\bar{u}; uv\bar{u}; \bar{u}vu; u\bar{v}u.$
- (24r)  $0uv; 0\bar{u}\bar{v}; 0u\bar{v}; 0\bar{u}v;$   
 $v0u; \bar{v}0\bar{u}; \bar{v}0u; v0\bar{u};$   
 $uv0; \bar{u}\bar{v}0; u\bar{v}0; \bar{u}v0;$   
 $\frac{1}{2}-u, \frac{1}{2}, \frac{1}{2}-v, u+\frac{1}{2}, \frac{1}{2}, v+\frac{1}{2}; \frac{1}{2}-u, \frac{1}{2}, v+\frac{1}{2}; u+\frac{1}{2}, \frac{1}{2}, \frac{1}{2}-v;$   
 $\frac{1}{2}, \frac{1}{2}-v, \frac{1}{2}-u; \frac{1}{2}, v+\frac{1}{2}, u+\frac{1}{2}; \frac{1}{2}, v+\frac{1}{2}, \frac{1}{2}-u; \frac{1}{2}, \frac{1}{2}-v, u+\frac{1}{2};$   
 $\frac{1}{2}-v, \frac{1}{2}-u, \frac{1}{2}; v+\frac{1}{2}, u+\frac{1}{2}, \frac{1}{2}; v+\frac{1}{2}, \frac{1}{2}-u, \frac{1}{2}; \frac{1}{2}-v, u+\frac{1}{2}, \frac{1}{2}.$
- (24s)  $u, \frac{1}{2}-u, \frac{1}{2}; u, u+\frac{1}{2}, \frac{1}{2}; \bar{u}, \frac{1}{2}-\bar{u}, \frac{1}{2}; \bar{u}, u+\frac{1}{2}, \frac{1}{2};$   
 $\frac{1}{2}, u, \frac{1}{2}-u; \frac{1}{2}, u, u+\frac{1}{2}; \frac{1}{2}, \bar{u}, \frac{1}{2}-\bar{u}; \frac{1}{2}, \bar{u}, u+\frac{1}{2};$   
 $\frac{1}{2}-u, \frac{1}{2}, u; u+\frac{1}{2}, \frac{1}{2}, u; \frac{1}{2}-u, \frac{1}{2}, \bar{u}; u+\frac{1}{2}, \frac{1}{2}, \bar{u};$   
 $\bar{u}, u+\frac{1}{2}, \frac{1}{2}; \bar{u}, \frac{1}{2}-\bar{u}, \frac{1}{2}; u, u+\frac{1}{2}, \frac{1}{2}; u, \frac{1}{2}-u, \frac{1}{2};$   
 $\frac{1}{2}, \bar{u}, u+\frac{1}{2}; \frac{1}{2}, \bar{u}, \frac{1}{2}-\bar{u}; \frac{1}{2}, u, u+\frac{1}{2}; \frac{1}{2}, u, \frac{1}{2}-u;$   
 $u+\frac{1}{2}, \frac{1}{2}, \bar{u}; \frac{1}{2}-u, \frac{1}{2}, \bar{u}; u+\frac{1}{2}, \frac{1}{2}, u; \frac{1}{2}-u, \frac{1}{2}, u.$
- (24t)  $u, \frac{1}{2}-u, \frac{1}{2}; u, u+\frac{1}{2}, \frac{1}{2}; \bar{u}, \frac{1}{2}-\bar{u}, \frac{1}{2}; \bar{u}, u+\frac{1}{2}, \frac{1}{2};$   
 $\frac{1}{2}, u, \frac{1}{2}-u; \frac{1}{2}, u, u+\frac{1}{2}; \frac{1}{2}, \bar{u}, \frac{1}{2}-\bar{u}; \frac{1}{2}, \bar{u}, u+\frac{1}{2};$   
 $\frac{1}{2}-u, \frac{1}{2}, u; u+\frac{1}{2}, \frac{1}{2}, u; \frac{1}{2}-u, \frac{1}{2}, \bar{u}; u+\frac{1}{2}, \frac{1}{2}, \bar{u};$   
 $\frac{1}{2}-u, u, \frac{1}{2}; u+\frac{1}{2}, u, \frac{1}{2}; \frac{1}{2}-u, \bar{u}, \frac{1}{2}; u+\frac{1}{2}, \bar{u}, \frac{1}{2};$   
 $u, \frac{1}{2}, \frac{1}{2}-u; u, \frac{1}{2}, u+\frac{1}{2}; \bar{u}, \frac{1}{2}, \frac{1}{2}-\bar{u}; \bar{u}, \frac{1}{2}, u+\frac{1}{2};$   
 $\frac{1}{2}, \frac{1}{2}-u, u; \frac{1}{2}, u+\frac{1}{2}, u; \frac{1}{2}, \frac{1}{2}-u, \bar{u}; \frac{1}{2}, u+\frac{1}{2}, \bar{u}.$
- (24u)  $uu\bar{v}; u\bar{u}\bar{v}; \bar{u}u\bar{v}; \bar{u}\bar{u}v;$   
 $vuu; \bar{v}u\bar{u}; \bar{v}\bar{u}u; v\bar{u}\bar{u};$   
 $uvu; \bar{u}\bar{v}u; u\bar{v}\bar{u}; \bar{u}v\bar{u};$   
 $\frac{1}{2}-u, \frac{1}{2}-u, \frac{1}{2}-v; \frac{1}{2}-u, u+\frac{1}{2}, v+\frac{1}{2}; u+\frac{1}{2}, \frac{1}{2}-u, v+\frac{1}{2};$   
 $u+\frac{1}{2}, u+\frac{1}{2}, \frac{1}{2}-v;$   
 $\frac{1}{2}-v, \frac{1}{2}-u, \frac{1}{2}-u; v+\frac{1}{2}, \frac{1}{2}-u, u+\frac{1}{2}; v+\frac{1}{2}, u+\frac{1}{2}, \frac{1}{2}-u;$   
 $\frac{1}{2}-v, u+\frac{1}{2}, u+\frac{1}{2};$   
 $\frac{1}{2}-u, \frac{1}{2}-v, \frac{1}{2}-u; u+\frac{1}{2}, v+\frac{1}{2}, \frac{1}{2}-u; \frac{1}{2}-u, v+\frac{1}{2}, u+\frac{1}{2};$   
 $u+\frac{1}{2}, \frac{1}{2}-v, u+\frac{1}{2}.$



THIRTY-TWO EQUIVALENT POSITIONS.—*Continued.*

- (32d)  $\frac{1}{8} \frac{1}{8} \frac{1}{8}; \frac{1}{8} \frac{7}{8} \frac{7}{8}; \frac{7}{8} \frac{1}{8} \frac{7}{8}; \frac{7}{8} \frac{7}{8} \frac{1}{8};$   
 $\frac{3}{8} \frac{1}{8} \frac{3}{8}; \frac{1}{8} \frac{3}{8} \frac{3}{8}; \frac{3}{8} \frac{3}{8} \frac{1}{8}; \frac{3}{8} \frac{3}{8} \frac{3}{8};$   
 $\frac{5}{8} \frac{7}{8} \frac{7}{8}; \frac{7}{8} \frac{5}{8} \frac{7}{8}; \frac{7}{8} \frac{7}{8} \frac{5}{8}; \frac{3}{8} \frac{5}{8} \frac{3}{8};$   
 $\frac{5}{8} \frac{3}{8} \frac{3}{8}; \frac{3}{8} \frac{5}{8} \frac{5}{8}; \frac{5}{8} \frac{5}{8} \frac{1}{8}; \frac{5}{8} \frac{3}{8} \frac{7}{8};$   
 $\frac{3}{8} \frac{5}{8} \frac{7}{8}; \frac{7}{8} \frac{5}{8} \frac{3}{8}; \frac{5}{8} \frac{7}{8} \frac{3}{8}; \frac{1}{8} \frac{1}{8} \frac{5}{8};$   
 $\frac{1}{8} \frac{3}{8} \frac{7}{8}; \frac{3}{8} \frac{1}{8} \frac{7}{8}; \frac{7}{8} \frac{1}{8} \frac{3}{8}; \frac{1}{8} \frac{7}{8} \frac{3}{8};$   
 $\frac{5}{8} \frac{1}{8} \frac{5}{8}; \frac{3}{8} \frac{7}{8} \frac{5}{8}; \frac{7}{8} \frac{3}{8} \frac{5}{8}; \frac{1}{8} \frac{5}{8} \frac{1}{8};$   
 $\frac{3}{8} \frac{7}{8} \frac{1}{8}; \frac{7}{8} \frac{3}{8} \frac{1}{8}; \frac{1}{8} \frac{5}{8} \frac{5}{8}; \frac{5}{8} \frac{1}{8} \frac{1}{8};$
- (32e)  $\frac{3}{8} \frac{3}{8} \frac{3}{8}; \frac{7}{8} \frac{7}{8} \frac{7}{8}; \frac{7}{8} \frac{7}{8} \frac{3}{8}; \frac{3}{8} \frac{3}{8} \frac{7}{8};$   
 $\frac{7}{8} \frac{3}{8} \frac{7}{8}; \frac{3}{8} \frac{7}{8} \frac{3}{8}; \frac{3}{8} \frac{7}{8} \frac{7}{8}; \frac{7}{8} \frac{3}{8} \frac{3}{8};$   
 $\frac{3}{8} \frac{5}{8} \frac{5}{8}; \frac{5}{8} \frac{7}{8} \frac{5}{8}; \frac{3}{8} \frac{1}{8} \frac{3}{8}; \frac{1}{8} \frac{7}{8} \frac{1}{8};$   
 $\frac{7}{8} \frac{1}{8} \frac{5}{8}; \frac{1}{8} \frac{3}{8} \frac{5}{8}; \frac{7}{8} \frac{5}{8} \frac{1}{8}; \frac{5}{8} \frac{3}{8} \frac{1}{8};$   
 $\frac{5}{8} \frac{3}{8} \frac{5}{8}; \frac{7}{8} \frac{5}{8} \frac{5}{8}; \frac{1}{8} \frac{3}{8} \frac{1}{8}; \frac{7}{8} \frac{1}{8} \frac{1}{8};$   
 $\frac{1}{8} \frac{7}{8} \frac{5}{8}; \frac{3}{8} \frac{1}{8} \frac{5}{8}; \frac{5}{8} \frac{7}{8} \frac{1}{8}; \frac{3}{8} \frac{5}{8} \frac{1}{8};$   
 $\frac{5}{8} \frac{5}{8} \frac{3}{8}; \frac{5}{8} \frac{5}{8} \frac{7}{8}; \frac{1}{8} \frac{1}{8} \frac{3}{8}; \frac{1}{8} \frac{1}{8} \frac{7}{8};$   
 $\frac{1}{8} \frac{5}{8} \frac{7}{8}; \frac{1}{8} \frac{5}{8} \frac{3}{8}; \frac{5}{8} \frac{1}{8} \frac{7}{8}; \frac{5}{8} \frac{1}{8} \frac{3}{8}.$
- (32f)  $u u u; u, \bar{u}, \frac{1}{2}-u; \frac{1}{2}-u, u, \bar{u}; \bar{u}, \frac{1}{2}-u, u;$   
 $\frac{1}{4}-u, \frac{1}{4}-u, \frac{1}{4}-u; u+\frac{1}{4}, \frac{1}{4}-u, u+\frac{3}{4}; \frac{1}{4}-u, u+\frac{3}{4}, u+\frac{1}{4};$   
 $u+\frac{3}{4}, u+\frac{1}{4}, \frac{1}{4}-u;$   
 $\bar{u} \bar{u} \bar{u}; \bar{u}, u, u+\frac{1}{2}; u+\frac{1}{2}, \bar{u}, u; u, u+\frac{1}{2}, \bar{u};$   
 $u+\frac{1}{4}, u+\frac{1}{4}, u+\frac{1}{4}; \frac{1}{4}-u, u+\frac{1}{4}, \frac{3}{4}-u; u+\frac{1}{4}, \frac{3}{4}-u, \frac{1}{4}-u;$   
 $\frac{3}{4}-u, \frac{1}{4}-u, u+\frac{1}{4};$   
 $u+\frac{1}{2}, u+\frac{1}{2}, u+\frac{1}{2}; u+\frac{1}{2}, \frac{1}{2}-u, \bar{u}; \bar{u}, u+\frac{1}{2}, \frac{1}{2}-u;$   
 $\frac{1}{2}-u, \bar{u}, u+\frac{1}{2};$   
 $\frac{3}{4}-u, \frac{3}{4}-u, \frac{3}{4}-u; u+\frac{3}{4}, \frac{3}{4}-u, u+\frac{1}{4}; \frac{3}{4}-u, u+\frac{1}{4}, u+\frac{3}{4};$   
 $u+\frac{1}{4}, u+\frac{3}{4}, \frac{3}{4}-u;$   
 $\frac{1}{2}-u, \frac{1}{2}-u, \frac{1}{2}-u; \frac{1}{2}-u, u+\frac{1}{2}, u; u, \frac{1}{2}-u, u+\frac{1}{2};$   
 $u+\frac{1}{2}, u, \frac{1}{2}-u;$   
 $u+\frac{3}{4}, u+\frac{3}{4}, u+\frac{3}{4}; \frac{3}{4}-u, u+\frac{3}{4}, \frac{1}{4}-u; u+\frac{3}{4}, \frac{1}{4}-u, \frac{3}{4}-u;$   
 $\frac{1}{4}-u, \frac{3}{4}-u, u+\frac{3}{4}.$

## FORTY-EIGHT EQUIVALENT POSITIONS.

- (48a)  $\frac{1}{4} \frac{1}{4} u; \frac{3}{4} \frac{3}{4} \bar{u}; u+\frac{1}{2}, \frac{3}{4}, \frac{1}{4}; \frac{1}{4}, \frac{1}{2}-u, \frac{3}{4};$   
 $\frac{1}{4} \frac{3}{4} \bar{u}; \frac{3}{4} \frac{1}{4} u; \frac{1}{2}-u, \frac{3}{4}, \frac{3}{4}; \frac{3}{4}, u+\frac{1}{2}, \frac{3}{4};$   
 $\frac{3}{4} \frac{1}{4} \bar{u}; \frac{1}{4} \frac{3}{4} u; \frac{1}{2}-u, \frac{1}{4}, \frac{1}{4}; \frac{1}{4}, u+\frac{1}{2}, \frac{1}{4};$   
 $\frac{3}{4} \frac{3}{4} u; \frac{1}{4} \frac{1}{4} \bar{u}; u+\frac{1}{2}, \frac{1}{4}, \frac{3}{4}; \frac{3}{4}, \frac{1}{2}-u, \frac{1}{4};$   
 $u \frac{1}{4} \frac{1}{4}; \bar{u} \frac{3}{4} \frac{3}{4}; \frac{3}{4}, u+\frac{1}{2}, \frac{1}{4}; \frac{3}{4}, \frac{1}{4}, u+\frac{1}{2};$   
 $\bar{u} \frac{1}{4} \frac{3}{4}; u \frac{3}{4} \frac{1}{4}; \frac{1}{4}, \frac{1}{2}-u, \frac{1}{4}; \frac{3}{4}, \frac{3}{4}, \frac{1}{2}-u;$   
 $\bar{u} \frac{3}{4} \frac{1}{4}; u \frac{1}{4} \frac{3}{4}; \frac{3}{4}, \frac{1}{2}-u, \frac{3}{4}; \frac{1}{4}, \frac{1}{4}, \frac{1}{2}-u;$   
 $u \frac{3}{4} \frac{3}{4}; \bar{u} \frac{1}{4} \frac{1}{4}; \frac{1}{4}, u+\frac{1}{2}, \frac{3}{4}; \frac{1}{4}, \frac{3}{4}, u+\frac{1}{2};$   
 $\frac{1}{4} u \frac{1}{4}; \frac{3}{4} \bar{u} \frac{3}{4}; \frac{1}{2}-u, \frac{1}{4}, \frac{3}{4}; \frac{1}{4}, \frac{3}{4}, \frac{1}{2}-u;$   
 $\frac{3}{4} \bar{u} \frac{1}{4}; \frac{1}{4} u \frac{3}{4}; u+\frac{1}{2}, \frac{1}{4}, \frac{1}{4}; \frac{1}{4}, \frac{1}{4}, u+\frac{1}{2};$   
 $\frac{1}{4} \bar{u} \frac{3}{4}; \frac{3}{4} u \frac{1}{4}; u+\frac{1}{2}, \frac{3}{4}, \frac{3}{4}; \frac{3}{4}, \frac{3}{4}, u+\frac{1}{2};$   
 $\frac{3}{4} u \frac{3}{4}; \frac{1}{4} \bar{u} \frac{1}{4}; \frac{1}{2}-u, \frac{3}{4}, \frac{1}{4}; \frac{3}{4}, \frac{1}{4}, \frac{1}{2}-u.$

FORTY-EIGHT EQUIVALENT POSITIONS.—Continued.

- (48b)  $0uv$ ;  $\frac{1}{2}, u+\frac{1}{2}, v$ ;  $\frac{1}{2}, u, v+\frac{1}{2}$ ;  $0, u+\frac{1}{2}, v+\frac{1}{2}$ ;  
 $0\bar{u}\bar{v}$ ;  $\frac{1}{2}, \frac{1}{2}-u, \bar{v}$ ;  $\frac{1}{2}, \bar{u}, \frac{1}{2}-v$ ;  $0, \frac{1}{2}-u, \frac{1}{2}-v$ ;  
 $0u\bar{v}$ ;  $\frac{1}{2}, u+\frac{1}{2}, \bar{v}$ ;  $\frac{1}{2}, u, \frac{1}{2}-v$ ;  $0, u+\frac{1}{2}, \frac{1}{2}-v$ ;  
 $0\bar{u}v$ ;  $\frac{1}{2}, \frac{1}{2}-u, v$ ;  $\frac{1}{2}, \bar{u}, v+\frac{1}{2}$ ;  $0, \frac{1}{2}-u, v+\frac{1}{2}$ ;  
 $v0u$ ;  $v+\frac{1}{2}, \frac{1}{2}, u$ ;  $v+\frac{1}{2}, 0, u+\frac{1}{2}$ ;  $v, \frac{1}{2}, u+\frac{1}{2}$ ;  
 $\bar{v}0\bar{u}$ ;  $\frac{1}{2}-v, \frac{1}{2}, \bar{u}$ ;  $\frac{1}{2}-v, 0, \frac{1}{2}-u$ ;  $\bar{v}, \frac{1}{2}, \frac{1}{2}-u$ ;  
 $\bar{v}0u$ ;  $\frac{1}{2}-v, \frac{1}{2}, u$ ;  $\frac{1}{2}-v, 0, u+\frac{1}{2}$ ;  $\bar{v}, \frac{1}{2}, u+\frac{1}{2}$ ;  
 $v0\bar{u}$ ;  $v+\frac{1}{2}, \frac{1}{2}, \bar{u}$ ;  $v+\frac{1}{2}, 0, \frac{1}{2}-u$ ;  $v, \frac{1}{2}, \frac{1}{2}-u$ ;  
 $uv0$ ;  $u+\frac{1}{2}, v+\frac{1}{2}, 0$ ;  $u+\frac{1}{2}, v, \frac{1}{2}$ ;  $u, v+\frac{1}{2}, \frac{1}{2}$ ;  
 $\bar{u}\bar{v}0$ ;  $\frac{1}{2}-u, \frac{1}{2}-v, 0$ ;  $\frac{1}{2}-u, \bar{v}, \frac{1}{2}$ ;  $\bar{u}, \frac{1}{2}-v, \frac{1}{2}$ ;  
 $u\bar{v}0$ ;  $u+\frac{1}{2}, \frac{1}{2}-v, 0$ ;  $u+\frac{1}{2}, \bar{v}, \frac{1}{2}$ ;  $u, \frac{1}{2}-v, \frac{1}{2}$ ;  
 $\bar{u}v0$ ;  $\frac{1}{2}-u, v+\frac{1}{2}, 0$ ;  $\frac{1}{2}-u, v, \frac{1}{2}$ ;  $\bar{u}, v+\frac{1}{2}, \frac{1}{2}$ .
- (48c)  $u00$ ;  $u+\frac{1}{2}, \frac{1}{2}, 0$ ;  $u+\frac{1}{2}, 0, \frac{1}{2}$ ;  $u\frac{1}{2}\frac{1}{2}$ ;  
 $\bar{u}00$ ;  $\frac{1}{2}-u, \frac{1}{2}, 0$ ;  $\frac{1}{2}-u, 0, \frac{1}{2}$ ;  $\bar{u}\frac{1}{2}\frac{1}{2}$ ;  
 $0u0$ ;  $\frac{1}{2}, u+\frac{1}{2}, 0$ ;  $\frac{1}{2}u\frac{1}{2}$ ;  $0, u+\frac{1}{2}, \frac{1}{2}$ ;  
 $0\bar{u}0$ ;  $\frac{1}{2}, \frac{1}{2}-u, 0$ ;  $\frac{1}{2}\bar{u}\frac{1}{2}$ ;  $0, \frac{1}{2}-u, \frac{1}{2}$ ;  
 $00u$ ;  $\frac{1}{2}\frac{1}{2}u$ ;  $\frac{1}{2}, 0, u+\frac{1}{2}$ ;  $0, \frac{1}{2}, u+\frac{1}{2}$ ;  
 $00\bar{u}$ ;  $\frac{1}{2}\frac{1}{2}\bar{u}$ ;  $\frac{1}{2}, 0, \frac{1}{2}-u$ ;  $0, \frac{1}{2}, \frac{1}{2}-u$ ;  
 $\frac{1}{2}-u, \frac{1}{2}, \frac{1}{2}$ ;  $\frac{1}{2}-u, \frac{1}{2}, \frac{1}{2}$ ;  $\frac{1}{2}-u, \frac{1}{2}, \frac{1}{2}$ ;  $\frac{1}{2}-u, \frac{1}{2}, \frac{1}{2}$ ;  
 $u+\frac{1}{2}, \frac{1}{2}, \frac{1}{2}$ ;  $u+\frac{1}{2}, \frac{1}{2}, \frac{1}{2}$ ;  $u+\frac{1}{2}, \frac{1}{2}, \frac{1}{2}$ ;  $u+\frac{1}{2}, \frac{1}{2}, \frac{1}{2}$ ;  
 $\frac{1}{2}, \frac{1}{2}-u, \frac{1}{2}$ ;  $\frac{1}{2}, \frac{1}{2}-u, \frac{1}{2}$ ;  $\frac{1}{2}, \frac{1}{2}-u, \frac{1}{2}$ ;  $\frac{1}{2}, \frac{1}{2}-u, \frac{1}{2}$ ;  
 $\frac{1}{2}, u+\frac{1}{2}, \frac{1}{2}$ ;  $\frac{1}{2}, u+\frac{1}{2}, \frac{1}{2}$ ;  $\frac{1}{2}, u+\frac{1}{2}, \frac{1}{2}$ ;  $\frac{1}{2}, u+\frac{1}{2}, \frac{1}{2}$ ;  
 $\frac{1}{2}, \frac{1}{2}, \frac{1}{2}-u$ ;  $\frac{1}{2}, \frac{1}{2}, \frac{1}{2}-u$ ;  $\frac{1}{2}, \frac{1}{2}, \frac{1}{2}-u$ ;  $\frac{1}{2}, \frac{1}{2}, \frac{1}{2}-u$ ;  
 $\frac{1}{2}, \frac{1}{2}, u+\frac{1}{2}$ ;  $\frac{1}{2}, \frac{1}{2}, u+\frac{1}{2}$ ;  $\frac{1}{2}, \frac{1}{2}, u+\frac{1}{2}$ ;  $\frac{1}{2}, \frac{1}{2}, u+\frac{1}{2}$ .
- (48d)  $uu\bar{v}$ ;  $u\bar{u}\bar{v}$ ;  $\bar{u}u\bar{v}$ ;  $\bar{u}\bar{u}v$ ;  
 $vuu$ ;  $\bar{v}u\bar{u}$ ;  $\bar{v}\bar{u}u$ ;  $v\bar{u}\bar{u}$ ;  
 $uvu$ ;  $\bar{u}\bar{v}u$ ;  $u\bar{v}\bar{u}$ ;  $\bar{u}v\bar{u}$ ;  
 $u+\frac{1}{2}, u+\frac{1}{2}, v$ ;  $u+\frac{1}{2}, \frac{1}{2}-u, \bar{v}$ ;  $\frac{1}{2}-u, u+\frac{1}{2}, \bar{v}$ ;  $\frac{1}{2}-u, \frac{1}{2}-u, v$ ;  
 $v+\frac{1}{2}, u+\frac{1}{2}, u$ ;  $\frac{1}{2}-v, u+\frac{1}{2}, \bar{u}$ ;  $\frac{1}{2}-v, \frac{1}{2}-u, u$ ;  $v+\frac{1}{2}, \frac{1}{2}-u, \bar{u}$ ;  
 $u+\frac{1}{2}, v+\frac{1}{2}, u$ ;  $\frac{1}{2}-u, \frac{1}{2}-v, u$ ;  $u+\frac{1}{2}, \frac{1}{2}-v, \bar{u}$ ;  $\frac{1}{2}-u, v+\frac{1}{2}, \bar{u}$ ;  
 $u+\frac{1}{2}, u, v+\frac{1}{2}$ ;  $u+\frac{1}{2}, \bar{u}, \frac{1}{2}-v$ ;  $\frac{1}{2}-u, u, \frac{1}{2}-v$ ;  $\frac{1}{2}-u, \bar{u}, v+\frac{1}{2}$ ;  
 $v+\frac{1}{2}, u, u+\frac{1}{2}$ ;  $\frac{1}{2}-v, u, \frac{1}{2}-u$ ;  $\frac{1}{2}-v, \bar{u}, u+\frac{1}{2}$ ;  $v+\frac{1}{2}, \bar{u}, \frac{1}{2}-u$ ;  
 $u+\frac{1}{2}, v, u+\frac{1}{2}$ ;  $\frac{1}{2}-u, \bar{v}, u+\frac{1}{2}$ ;  $u+\frac{1}{2}, \bar{v}, \frac{1}{2}-u$ ;  $\frac{1}{2}-u, v, \frac{1}{2}-u$ ;  
 $u, u+\frac{1}{2}, v+\frac{1}{2}$ ;  $u, \frac{1}{2}-u, \frac{1}{2}-v$ ;  $\bar{u}, u+\frac{1}{2}, \frac{1}{2}-v$ ;  $\bar{u}, \frac{1}{2}-u, v+\frac{1}{2}$ ;  
 $v, u+\frac{1}{2}, u+\frac{1}{2}$ ;  $\bar{v}, u+\frac{1}{2}, \frac{1}{2}-u$ ;  $\bar{v}, \frac{1}{2}-u, u+\frac{1}{2}$ ;  $v, \frac{1}{2}-u, \frac{1}{2}-u$ ;  
 $u, v+\frac{1}{2}, u+\frac{1}{2}$ ;  $\bar{u}, \frac{1}{2}-v, u+\frac{1}{2}$ ;  $u, \frac{1}{2}-v, \frac{1}{2}-u$ ;  $\bar{u}, v+\frac{1}{2}, \frac{1}{2}-u$ ;
- (48e)  $u00$ ;  $u+\frac{1}{2}, \frac{1}{2}, 0$ ;  $u+\frac{1}{2}, 0, \frac{1}{2}$ ;  $u\frac{1}{2}\frac{1}{2}$ ;  
 $0u0$ ;  $\frac{1}{2}, u+\frac{1}{2}, 0$ ;  $\frac{1}{2}u\frac{1}{2}$ ;  $0, u+\frac{1}{2}, \frac{1}{2}$ ;  
 $00u$ ;  $\frac{1}{2}\frac{1}{2}u$ ;  $\frac{1}{2}, 0, u+\frac{1}{2}$ ;  $0, \frac{1}{2}, u+\frac{1}{2}$ ;  
 $\bar{u}00$ ;  $\frac{1}{2}-u, \frac{1}{2}, 0$ ;  $\frac{1}{2}-u, 0, \frac{1}{2}$ ;  $\bar{u}\frac{1}{2}\frac{1}{2}$ ;  
 $0\bar{u}0$ ;  $\frac{1}{2}, \frac{1}{2}-u, 0$ ;  $\frac{1}{2}\bar{u}\frac{1}{2}$ ;  $0, \frac{1}{2}-u, \frac{1}{2}$ ;  
 $00\bar{u}$ ;  $\frac{1}{2}\frac{1}{2}\bar{u}$ ;  $\frac{1}{2}, 0, \frac{1}{2}-u$ ;  $0, \frac{1}{2}, \frac{1}{2}-u$ ;  
 $u+\frac{1}{2}, \frac{1}{2}, \frac{1}{2}$ ;  $u0\frac{1}{2}$ ;  $u\frac{1}{2}0$ ;  $u+\frac{1}{2}, 0, 0$ ;  
 $\frac{1}{2}, u+\frac{1}{2}, \frac{1}{2}$ ;  $0u\frac{1}{2}$ ;  $0, u+\frac{1}{2}, 0$ ;  $\frac{1}{2}u0$ ;

FORTY-EIGHT EQUIVALENT POSITIONS.—Continued.

- $\frac{1}{2}, \frac{1}{2}, u+\frac{1}{2}; 0, 0, u+\frac{1}{2}; 0 \frac{1}{2} u; \frac{1}{2} 0 u;$   
 $\frac{1}{2}, \frac{1}{2}-u, \frac{1}{2}; 0 \bar{u} \frac{1}{2}; 0, \frac{1}{2}-u, 0; \frac{1}{2} \bar{u} 0;$   
 $\frac{1}{2}-u, \frac{1}{2}, \frac{1}{2}; \bar{u} 0 \frac{1}{2}; \bar{u} \frac{1}{2} 0; \frac{1}{2}-u, 0, 0;$   
 $\frac{1}{2}, \frac{1}{2}, \frac{1}{2}-u; 0, 0, \frac{1}{2}-u; 0 \frac{1}{2} \bar{u}; \frac{1}{2} 0 \bar{u}.$
- (48f)  $u \bar{u} 0; u+\frac{1}{2}, \frac{1}{2}-u, 0; u+\frac{1}{2}, \bar{u}, \frac{1}{2}; u, \frac{1}{2}-u, \frac{1}{2};$   
 $0 u \bar{u}; \frac{1}{2}, u+\frac{1}{2}, \bar{u}; \frac{1}{2}, u, \frac{1}{2}-u; 0, u+\frac{1}{2}, \frac{1}{2}-u;$   
 $\bar{u} 0 u; \frac{1}{2}-u, \frac{1}{2}, u; \frac{1}{2}-u, 0, u+\frac{1}{2}; \bar{u}, \frac{1}{2}, u+\frac{1}{2};$   
 $u u 0; u+\frac{1}{2}, u+\frac{1}{2}, 0; u+\frac{1}{2}, u, \frac{1}{2}; u, u+\frac{1}{2}, \frac{1}{2};$   
 $0 u u; \frac{1}{2}, u+\frac{1}{2}, u; \frac{1}{2}, u, u+\frac{1}{2}; 0, u+\frac{1}{2}, u+\frac{1}{2};$   
 $u 0 u; u+\frac{1}{2}, \frac{1}{2}, u; u+\frac{1}{2}, 0, u+\frac{1}{2}; u, \frac{1}{2}, u+\frac{1}{2};$   
 $\bar{u} \bar{u} 0; \frac{1}{2}-u, \frac{1}{2}-u, 0; \frac{1}{2}-u, \bar{u}, \frac{1}{2}; \bar{u}, \frac{1}{2}-u, \frac{1}{2};$   
 $0 \bar{u} \bar{u}; \frac{1}{2}, \frac{1}{2}-u, \bar{u}; \frac{1}{2}, \bar{u}, \frac{1}{2}-u; 0, \frac{1}{2}-u, \frac{1}{2}-u;$   
 $\bar{u} 0 \bar{u}; \frac{1}{2}-u, \frac{1}{2}, \bar{u}; \frac{1}{2}-u, 0, \frac{1}{2}-u; \bar{u}, \frac{1}{2}, \frac{1}{2}-u;$   
 $\bar{u} u 0; \frac{1}{2}-u, u+\frac{1}{2}, 0; \frac{1}{2}-u, u, \frac{1}{2}; \bar{u}, u+\frac{1}{2}, \frac{1}{2};$   
 $0 \bar{u} u; \frac{1}{2}, \frac{1}{2}-u, u; \frac{1}{2}, \bar{u}, u+\frac{1}{2}; 0, \frac{1}{2}-u, u+\frac{1}{2};$   
 $u 0 \bar{u}; u+\frac{1}{2}, \frac{1}{2}, \bar{u}; u+\frac{1}{2}, 0, \frac{1}{2}-u; u, \frac{1}{2}, \frac{1}{2}-u.$
- (48g)  $u \bar{u} \frac{1}{2}; u+\frac{1}{2}, \frac{1}{2}-u, \frac{1}{2}; u+\frac{1}{2}, \bar{u}, 0; u, \frac{1}{2}-u, 0;$   
 $\frac{1}{2} u \bar{u}; 0, u+\frac{1}{2}, \bar{u}; 0, u, \frac{1}{2}-u; \frac{1}{2}, u+\frac{1}{2}, \frac{1}{2}-u;$   
 $\bar{u} \frac{1}{2} u; \frac{1}{2}-u, 0, u; \frac{1}{2}-u, \frac{1}{2}, u+\frac{1}{2}; \bar{u}, 0, u+\frac{1}{2};$   
 $u u \frac{1}{2}; u+\frac{1}{2}, u+\frac{1}{2}, \frac{1}{2}; u+\frac{1}{2}, u, 0; u, u+\frac{1}{2}, 0;$   
 $\frac{1}{2} u u; 0, u+\frac{1}{2}, u; 0, u, u+\frac{1}{2}; \frac{1}{2}, u+\frac{1}{2}, u+\frac{1}{2};$   
 $u \frac{1}{2} u; u+\frac{1}{2}, 0, u; u+\frac{1}{2}, \frac{1}{2}, u+\frac{1}{2}; u, 0, u+\frac{1}{2};$   
 $\bar{u} \bar{u} \frac{1}{2}; \frac{1}{2}-u, \frac{1}{2}-u, \frac{1}{2}; \frac{1}{2}-u, \bar{u}, 0; \bar{u}, \frac{1}{2}-u, 0;$   
 $\frac{1}{2} \bar{u} \bar{u}; 0, \frac{1}{2}-u, \bar{u}; 0, \bar{u}, \frac{1}{2}-u; \frac{1}{2}, \frac{1}{2}-u, \frac{1}{2}-u;$   
 $\bar{u} \frac{1}{2} \bar{u}; \frac{1}{2}-u, 0, \bar{u}; \frac{1}{2}-u, \frac{1}{2}, \frac{1}{2}-u; \bar{u}, 0, \frac{1}{2}-u;$   
 $\bar{u} u \frac{1}{2}; \frac{1}{2}-u, u+\frac{1}{2}, \frac{1}{2}; \frac{1}{2}-u, u, 0; \bar{u}, u+\frac{1}{2}, 0;$   
 $\frac{1}{2} \bar{u} u; 0, \frac{1}{2}-u, u; 0, \bar{u}, u+\frac{1}{2}; \frac{1}{2}, \frac{1}{2}-u, u+\frac{1}{2};$   
 $u \frac{1}{2} \bar{u}; u+\frac{1}{2}, 0, \bar{u}; u+\frac{1}{2}, \frac{1}{2}, \frac{1}{2}-u; u, 0, \frac{1}{2}-u.$
- (48h)  $u, \frac{1}{2}-u, \frac{1}{2}; u, u+\frac{1}{2}, \frac{1}{2}; \bar{u}, \frac{1}{2}-u, \frac{1}{2}; \bar{u}, u+\frac{1}{2}, \frac{1}{2};$   
 $\frac{1}{2}, u, \frac{1}{2}-u; \frac{1}{2}, u, u+\frac{1}{2}; \frac{1}{2}, \bar{u}, \frac{1}{2}-u; \frac{1}{2}, \bar{u}, u+\frac{1}{2};$   
 $\frac{1}{2}-u, \frac{1}{2}, u; u+\frac{1}{2}, \frac{1}{2}, u; \frac{1}{2}-u, \frac{1}{2}, \bar{u}; u+\frac{1}{2}, \frac{1}{2}, \bar{u};$   
 $u+\frac{1}{2}, \frac{1}{2}-u, \frac{1}{2}; u+\frac{1}{2}, u+\frac{1}{2}, \frac{1}{2}; \frac{1}{2}-u, \frac{1}{2}-u, \frac{1}{2}; \frac{1}{2}-u, u+\frac{1}{2}, \frac{1}{2};$   
 $\frac{1}{2}, u+\frac{1}{2}, \frac{1}{2}-u; \frac{1}{2}, u+\frac{1}{2}, u+\frac{1}{2}; \frac{1}{2}, \frac{1}{2}-u, \frac{1}{2}-u; \frac{1}{2}, \frac{1}{2}-u, u+\frac{1}{2};$   
 $\frac{1}{2}-u, \frac{1}{2}, u; u+\frac{1}{2}, \frac{1}{2}, u; \frac{1}{2}-u, \frac{1}{2}, \bar{u}; u+\frac{1}{2}, \frac{1}{2}, \bar{u};$   
 $u+\frac{1}{2}, \frac{1}{2}-u, \frac{1}{2}; u+\frac{1}{2}, u+\frac{1}{2}, \frac{1}{2}; \frac{1}{2}-u, \frac{1}{2}-u, \frac{1}{2}; \frac{1}{2}-u, u+\frac{1}{2}, \frac{1}{2};$   
 $\frac{1}{2}, u, \frac{1}{2}-u; \frac{1}{2}, u, u+\frac{1}{2}; \frac{1}{2}, \bar{u}, \frac{1}{2}-u; \frac{1}{2}, \bar{u}, u+\frac{1}{2};$   
 $\frac{1}{2}-u, \frac{1}{2}, u+\frac{1}{2}; u+\frac{1}{2}, \frac{1}{2}, u+\frac{1}{2}; \frac{1}{2}-u, \frac{1}{2}, \frac{1}{2}-u; u+\frac{1}{2}, \frac{1}{2}, \frac{1}{2}-u;$   
 $u, \frac{1}{2}-u, \frac{1}{2}; u, u+\frac{1}{2}, \frac{1}{2}; \bar{u}, \frac{1}{2}-u, \frac{1}{2}; \bar{u}, u+\frac{1}{2}, \frac{1}{2};$   
 $\frac{1}{2}, u+\frac{1}{2}, \frac{1}{2}-u; \frac{1}{2}, u+\frac{1}{2}, u+\frac{1}{2}; \frac{1}{2}, \frac{1}{2}-u, \frac{1}{2}-u; \frac{1}{2}, \frac{1}{2}-u, u+\frac{1}{2};$   
 $\frac{1}{2}-u, \frac{1}{2}, u+\frac{1}{2}; u+\frac{1}{2}, \frac{1}{2}, u+\frac{1}{2}; \frac{1}{2}-u, \frac{1}{2}, \frac{1}{2}-u; u+\frac{1}{2}, \frac{1}{2}, \frac{1}{2}-u.$
- (48i)  $\frac{1}{2} 0 0; \frac{1}{2} \frac{1}{2} 0; \frac{1}{2} 0 \frac{1}{2}; \frac{1}{2} \frac{1}{2} \frac{1}{2};$   
 $\frac{1}{2} 0 0; \frac{1}{2} \frac{1}{2} 0; \frac{1}{2} 0 \frac{1}{2}; \frac{1}{2} \frac{1}{2} \frac{1}{2};$   
 $0 \frac{1}{2} 0; \frac{1}{2} \frac{1}{2} 0; \frac{1}{2} \frac{1}{2} \frac{1}{2}; 0 \frac{1}{2} \frac{1}{2};$   
 $0 \frac{1}{2} 0; \frac{1}{2} \frac{1}{2} 0; \frac{1}{2} \frac{1}{2} \frac{1}{2}; 0 \frac{1}{2} \frac{1}{2};$

FORTY-EIGHT EQUIVALENT POSITIONS.—Continued.

- |       |   |   |   |   |  |
|-------|---|---|---|---|--|
|       | $00\frac{1}{2}$ ;                       | $\frac{1}{2}\frac{1}{2}\frac{1}{2}$ ;   | $\frac{1}{2}0\frac{1}{2}$ ;                     | $0\frac{1}{2}\frac{1}{2}$ ;                     |  |
|       | $00\frac{1}{2}$ ;                       | $\frac{1}{2}\frac{1}{2}\frac{1}{2}$ ;   | $\frac{1}{2}0\frac{1}{2}$ ;                     | $0\frac{1}{2}\frac{1}{2}$ ;                     |  |
|       | $\frac{1}{2}0\frac{1}{2}$ ;             | $\frac{1}{2}\frac{1}{2}\frac{1}{2}$ ;   | $\frac{1}{2}0\frac{1}{2}$ ;                     | $\frac{1}{2}\frac{1}{2}\frac{1}{2}$ ;           |  |
|       | $\frac{1}{2}\frac{1}{2}\frac{1}{2}$ ;   | $\frac{1}{2}0\frac{1}{2}$ ;             | $\frac{1}{2}\frac{1}{2}\frac{1}{2}$ ;           | $\frac{1}{2}0\frac{1}{2}$ ;                     |  |
|       | $0\frac{1}{2}\frac{1}{2}$ ;             | $\frac{1}{2}\frac{1}{2}\frac{1}{2}$ ;   | $\frac{1}{2}\frac{1}{2}\frac{1}{2}$ ;           | $0\frac{1}{2}\frac{1}{2}$ ;                     |  |
|       | $\frac{1}{2}\frac{1}{2}\frac{1}{2}$ ;   | $0\frac{1}{2}\frac{1}{2}$ ;             | $0\frac{1}{2}\frac{1}{2}$ ;                     | $\frac{1}{2}\frac{1}{2}\frac{1}{2}$ ;           |  |
|       | $\frac{1}{2}\frac{1}{2}0$ ;             | $\frac{1}{2}\frac{1}{2}0$ ;             | $\frac{1}{2}\frac{1}{2}\frac{1}{2}$ ;           | $\frac{1}{2}\frac{1}{2}\frac{1}{2}$ ;           |  |
|       | $\frac{1}{2}\frac{1}{2}\frac{1}{2}$ ;   | $\frac{1}{2}\frac{1}{2}\frac{1}{2}$ ;   | $\frac{1}{2}\frac{1}{2}0$ ;                     | $\frac{1}{2}\frac{1}{2}0$ ;                     |  |
| (48j) | $0u\bar{v}$ ;                           | $0u\bar{v}$ ;                           | $\frac{1}{2}, u+\frac{1}{2}, v+\frac{1}{2}$ ;   | $\frac{1}{2}, u+\frac{1}{2}, \frac{1}{2}-v$ ;   |  |
|       | $v0u$ ;                                 | $\bar{v}0u$ ;                           | $v+\frac{1}{2}, \frac{1}{2}, u+\frac{1}{2}$ ;   | $\frac{1}{2}-v, \frac{1}{2}, u+\frac{1}{2}$ ;   |  |
|       | $uv0$ ;                                 | $u\bar{v}0$ ;                           | $u+\frac{1}{2}, v+\frac{1}{2}, \frac{1}{2}$ ;   | $u+\frac{1}{2}, \frac{1}{2}-v, \frac{1}{2}$ ;   |  |
|       | $\bar{u}0\bar{v}$ ;                     | $\bar{u}0\bar{v}$ ;                     | $\frac{1}{2}-u, \frac{1}{2}, \frac{1}{2}-v$ ;   | $\frac{1}{2}-u, \frac{1}{2}, v+\frac{1}{2}$ ;   |  |
|       | $0\bar{v}\bar{u}$ ;                     | $0v\bar{u}$ ;                           | $\frac{1}{2}, \frac{1}{2}-v, \frac{1}{2}-u$ ;   | $\frac{1}{2}, v+\frac{1}{2}, \frac{1}{2}-u$ ;   |  |
|       | $\bar{v}\bar{u}0$ ;                     | $v\bar{u}0$ ;                           | $\frac{1}{2}-v, \frac{1}{2}-u, \frac{1}{2}$ ;   | $v+\frac{1}{2}, \frac{1}{2}-u, \frac{1}{2}$ ;   |  |
|       | $0\bar{u}\bar{v}$ ;                     | $0\bar{u}\bar{v}$ ;                     | $\frac{1}{2}, \frac{1}{2}-u, \frac{1}{2}-v$ ;   | $\frac{1}{2}, \frac{1}{2}-u, v+\frac{1}{2}$ ;   |  |
|       | $\bar{v}0\bar{u}$ ;                     | $v0\bar{u}$ ;                           | $\frac{1}{2}-v, \frac{1}{2}, \frac{1}{2}-u$ ;   | $v+\frac{1}{2}, \frac{1}{2}, \frac{1}{2}-u$ ;   |  |
|       | $\bar{u}\bar{v}0$ ;                     | $\bar{u}\bar{v}0$ ;                     | $\frac{1}{2}-u, \frac{1}{2}-v, \frac{1}{2}$ ;   | $\frac{1}{2}-u, v+\frac{1}{2}, \frac{1}{2}$ ;   |  |
|       | $u0\bar{v}$ ;                           | $u0\bar{v}$ ;                           | $u+\frac{1}{2}, \frac{1}{2}, v+\frac{1}{2}$ ;   | $u+\frac{1}{2}, \frac{1}{2}, \frac{1}{2}-v$ ;   |  |
|       | $0v\bar{u}$ ;                           | $0\bar{v}u$ ;                           | $\frac{1}{2}, v+\frac{1}{2}, u+\frac{1}{2}$ ;   | $\frac{1}{2}, \frac{1}{2}-v, u+\frac{1}{2}$ ;   |  |
|       | $v\bar{u}0$ ;                           | $\bar{v}u0$ ;                           | $v+\frac{1}{2}, u+\frac{1}{2}, \frac{1}{2}$ ;   | $\frac{1}{2}-v, u+\frac{1}{2}, \frac{1}{2}$ ;   |  |
| (48k) | $uu\bar{v}$ ;                           | $\bar{u}u\bar{v}$ ;                     | $u+\frac{1}{2}, u+\frac{1}{2}, v+\frac{1}{2}$ ; | $\frac{1}{2}-u, u+\frac{1}{2}, v+\frac{1}{2}$ ; |  |
|       | $vuu$ ;                                 | $v\bar{u}u$ ;                           | $v+\frac{1}{2}, u+\frac{1}{2}, u+\frac{1}{2}$ ; | $v+\frac{1}{2}, \frac{1}{2}-u, u+\frac{1}{2}$ ; |  |
|       | $uvu$ ;                                 | $uv\bar{u}$ ;                           | $u+\frac{1}{2}, v+\frac{1}{2}, u+\frac{1}{2}$ ; | $u+\frac{1}{2}, v+\frac{1}{2}, \frac{1}{2}-u$ ; |  |
|       | $\bar{u}\bar{u}\bar{v}$ ;               | $\bar{u}u\bar{v}$ ;                     | $\frac{1}{2}-u, \frac{1}{2}-u, \frac{1}{2}-v$ ; | $\frac{1}{2}-u, u+\frac{1}{2}, \frac{1}{2}-v$ ; |  |
|       | $\bar{u}\bar{v}\bar{u}$ ;               | $u\bar{v}\bar{u}$ ;                     | $\frac{1}{2}-u, \frac{1}{2}-v, \frac{1}{2}-u$ ; | $u+\frac{1}{2}, \frac{1}{2}-v, \frac{1}{2}-u$ ; |  |
|       | $\bar{v}\bar{u}\bar{u}$ ;               | $\bar{v}\bar{u}u$ ;                     | $\frac{1}{2}-v, \frac{1}{2}-u, \frac{1}{2}-u$ ; | $\frac{1}{2}-v, \frac{1}{2}-u, u+\frac{1}{2}$ ; |  |
|       | $u\bar{u}\bar{v}$ ;                     | $\bar{u}\bar{u}\bar{v}$ ;               | $u+\frac{1}{2}, \frac{1}{2}-u, \frac{1}{2}-v$ ; | $\frac{1}{2}-u, \frac{1}{2}-u, v+\frac{1}{2}$ ; |  |
|       | $\bar{v}u\bar{u}$ ;                     | $v\bar{u}\bar{u}$ ;                     | $\frac{1}{2}-v, u+\frac{1}{2}, \frac{1}{2}-u$ ; | $v+\frac{1}{2}, \frac{1}{2}-u, \frac{1}{2}-u$ ; |  |
|       | $\bar{u}\bar{v}u$ ;                     | $\bar{u}v\bar{u}$ ;                     | $\frac{1}{2}-u, \frac{1}{2}-v, u+\frac{1}{2}$ ; | $\frac{1}{2}-u, v+\frac{1}{2}, \frac{1}{2}-u$ ; |  |
|       | $u\bar{u}\bar{v}$ ;                     | $uu\bar{v}$ ;                           | $u+\frac{1}{2}, \frac{1}{2}-u, v+\frac{1}{2}$ ; | $u+\frac{1}{2}, u+\frac{1}{2}, \frac{1}{2}-v$ ; |  |
|       | $\bar{u}\bar{v}u$ ;                     | $u\bar{v}u$ ;                           | $\frac{1}{2}-u, v+\frac{1}{2}, u+\frac{1}{2}$ ; | $u+\frac{1}{2}, \frac{1}{2}-v, u+\frac{1}{2}$ ; |  |
|       | $v\bar{u}\bar{u}$ ;                     | $\bar{v}uu$ ;                           | $v+\frac{1}{2}, u+\frac{1}{2}, \frac{1}{2}-u$ ; | $\frac{1}{2}-v, u+\frac{1}{2}, u+\frac{1}{2}$ ; |  |
| (48l) | $u, u+\frac{1}{2}, \frac{1}{2}$ ;       | $u, \frac{1}{2}-u, \frac{1}{2}$ ;       | $\bar{u}, u+\frac{1}{2}, \frac{1}{2}$ ;         | $\bar{u}, \frac{1}{2}-u, \frac{1}{2}$ ;         |  |
|       | $\frac{1}{2}, u, u+\frac{1}{2}$ ;       | $\frac{1}{2}, u, \frac{1}{2}-u$ ;       | $\frac{1}{2}, \bar{u}, u+\frac{1}{2}$ ;         | $\frac{1}{2}, \bar{u}, \frac{1}{2}-u$ ;         |  |
|       | $u+\frac{1}{2}, \frac{1}{2}, u$ ;       | $\frac{1}{2}-u, \frac{1}{2}, u$ ;       | $u+\frac{1}{2}, \frac{1}{2}, \bar{u}$ ;         | $\frac{1}{2}-u, \frac{1}{2}, \bar{u}$ ;         |  |
|       | $u+\frac{1}{2}, u, \frac{1}{2}$ ;       | $\frac{1}{2}-u, u, \frac{1}{2}$ ;       | $u+\frac{1}{2}, \bar{u}, \frac{1}{2}$ ;         | $\frac{1}{2}-u, \bar{u}, \frac{1}{2}$ ;         |  |
|       | $u, \frac{1}{2}, u+\frac{1}{2}$ ;       | $u, \frac{1}{2}, \frac{1}{2}-u$ ;       | $\bar{u}, \frac{1}{2}, u+\frac{1}{2}$ ;         | $\bar{u}, \frac{1}{2}, \frac{1}{2}-u$ ;         |  |
|       | $\frac{1}{2}, u+\frac{1}{2}, u$ ;       | $\frac{1}{2}, \frac{1}{2}-u, u$ ;       | $\frac{1}{2}, u+\frac{1}{2}, \bar{u}$ ;         | $\frac{1}{2}, \frac{1}{2}-u, \bar{u}$ ;         |  |
|       | $\bar{u}, \frac{1}{2}-u, \frac{1}{2}$ ; | $\bar{u}, u+\frac{1}{2}, \frac{1}{2}$ ; | $u, \frac{1}{2}-u, \frac{1}{2}$ ;               | $u, u+\frac{1}{2}, \frac{1}{2}$ ;               |  |
|       | $\frac{1}{2}, \bar{u}, \frac{1}{2}-u$ ; | $\frac{1}{2}, \bar{u}, u+\frac{1}{2}$ ; | $\frac{1}{2}, u, \frac{1}{2}-u$ ;               | $\frac{1}{2}, u, u+\frac{1}{2}$ ;               |  |
|       | $\frac{1}{2}-u, \frac{1}{2}, \bar{u}$ ; | $u+\frac{1}{2}, \frac{1}{2}, \bar{u}$ ; | $\frac{1}{2}-u, \frac{1}{2}, u$ ;               | $u+\frac{1}{2}, \frac{1}{2}, u$ ;               |  |
|       | $\frac{1}{2}-u, \bar{u}, \frac{1}{2}$ ; | $u+\frac{1}{2}, \bar{u}, \frac{1}{2}$ ; | $\frac{1}{2}-u, u, \frac{1}{2}$ ;               | $u+\frac{1}{2}, u, \frac{1}{2}$ ;               |  |
|       | $\bar{u}, \frac{1}{2}, \frac{1}{2}-u$ ; | $\bar{u}, \frac{1}{2}, u+\frac{1}{2}$ ; | $u, \frac{1}{2}, \frac{1}{2}-u$ ;               | $u, \frac{1}{2}, u+\frac{1}{2}$ ;               |  |
|       | $\frac{1}{2}, \frac{1}{2}-u, \bar{u}$ ; | $\frac{1}{2}, u+\frac{1}{2}, \bar{u}$ ; | $\frac{1}{2}, \frac{1}{2}-u, u$ ;               | $\frac{1}{2}, u+\frac{1}{2}, u$ ;               |  |

FORTY-EIGHT EQUIVALENT POSITIONS.—Continued.

- (48m)  $u\ 0\ \frac{1}{2}$ ;  $u+\frac{1}{2}, \frac{1}{2}, \frac{1}{2}$ ;  $\frac{1}{2}-u, 0, \frac{1}{2}$ ;  $\bar{u}\ \frac{1}{2}\ \frac{1}{2}$ ;  
 $\frac{1}{2}\ u\ 0$ ;  $\frac{1}{2}, u+\frac{1}{2}, \frac{1}{2}$ ;  $\frac{1}{2}, \frac{1}{2}-u, 0$ ;  $\frac{1}{2}\ \bar{u}\ \frac{1}{2}$ ;  
 $0\ \frac{1}{2}\ u$ ;  $\frac{1}{2}, \frac{1}{2}, u+\frac{1}{2}$ ;  $0, \frac{1}{2}, \frac{1}{2}-u$ ;  $\frac{1}{2}\ \frac{1}{2}\ \bar{u}$ ;  
 $\frac{1}{2}, \frac{1}{2}-u, 0$ ;  $\frac{1}{2}, \frac{1}{2}-u, \frac{1}{2}$ ;  $\frac{1}{2}, u+\frac{1}{2}, \frac{1}{2}$ ;  $\frac{1}{2}, u+\frac{1}{2}, 0$ ;  
 $\frac{1}{2}-u, 0, \frac{1}{2}$ ;  $\frac{1}{2}-u, \frac{1}{2}, \frac{1}{2}$ ;  $u+\frac{1}{2}, \frac{1}{2}, \frac{1}{2}$ ;  $u+\frac{1}{2}, 0, \frac{1}{2}$ ;  
 $0, \frac{1}{2}, \frac{1}{2}-u$ ;  $\frac{1}{2}, \frac{1}{2}, \frac{1}{2}-u$ ;  $\frac{1}{2}, \frac{1}{2}, u+\frac{1}{2}$ ;  $0, \frac{1}{2}, u+\frac{1}{2}$ ;  
 $\bar{u}\ 0\ \frac{1}{2}$ ;  $\frac{1}{2}-u, \frac{1}{2}, \frac{1}{2}$ ;  $u\ \frac{1}{2}\ \frac{1}{2}$ ;  $u+\frac{1}{2}, 0, \frac{1}{2}$ ;  
 $\frac{1}{2}\ \bar{u}\ 0$ ;  $\frac{1}{2}, \frac{1}{2}-u, \frac{1}{2}$ ;  $\frac{1}{2}\ u\ \frac{1}{2}$ ;  $\frac{1}{2}, u+\frac{1}{2}, 0$ ;  
 $0\ \frac{1}{2}\ \bar{u}$ ;  $\frac{1}{2}, \frac{1}{2}, \frac{1}{2}-u$ ;  $\frac{1}{2}\ \frac{1}{2}\ u$ ;  $0, \frac{1}{2}, u+\frac{1}{2}$ ;  
 $\frac{1}{2}, u+\frac{1}{2}, \frac{1}{2}$ ;  $\frac{1}{2}, u+\frac{1}{2}, 0$ ;  $\frac{1}{2}, \frac{1}{2}-u, 0$ ;  $\frac{1}{2}, \frac{1}{2}-u, \frac{1}{2}$ ;  
 $u+\frac{1}{2}, \frac{1}{2}, \frac{1}{2}$ ;  $u+\frac{1}{2}, 0, \frac{1}{2}$ ;  $\frac{1}{2}-u, 0, \frac{1}{2}$ ;  $\frac{1}{2}-u, \frac{1}{2}, \frac{1}{2}$ ;  
 $\frac{1}{2}, \frac{1}{2}, u+\frac{1}{2}$ ;  $0, \frac{1}{2}, u+\frac{1}{2}$ ;  $0, \frac{1}{2}, \frac{1}{2}-u$ ;  $\frac{1}{2}, \frac{1}{2}, \frac{1}{2}-u$ .
- (48n)  $u, u+\frac{1}{2}, \frac{1}{2}$ ;  $\bar{u}, \frac{1}{2}-u, \frac{1}{2}$ ;  $u, \frac{1}{2}-u, \frac{1}{2}$ ;  $\bar{u}, u+\frac{1}{2}, \frac{1}{2}$ ;  
 $\frac{1}{2}, u, u+\frac{1}{2}$ ;  $\frac{1}{2}, \bar{u}, \frac{1}{2}-u$ ;  $\frac{1}{2}, u, \frac{1}{2}-u$ ;  $\frac{1}{2}, \bar{u}, u+\frac{1}{2}$ ;  
 $u+\frac{1}{2}, \frac{1}{2}, u$ ;  $\frac{1}{2}-u, \frac{1}{2}, \bar{u}$ ;  $\frac{1}{2}-u, \frac{1}{2}, u$ ;  $u+\frac{1}{2}, \frac{1}{2}, \bar{u}$ ;  
 $u+\frac{1}{2}, \frac{1}{2}-u, \frac{1}{2}$ ;  $\frac{1}{2}-u, u+\frac{1}{2}, \frac{1}{2}$ ;  $u+\frac{1}{2}, u+\frac{1}{2}, \frac{1}{2}$ ;  $\frac{1}{2}-u, \frac{1}{2}-u, \frac{1}{2}$ ;  
 $\frac{1}{2}, u+\frac{1}{2}, \frac{1}{2}-u$ ;  $\frac{1}{2}, \frac{1}{2}-u, u+\frac{1}{2}$ ;  $\frac{1}{2}, u+\frac{1}{2}, u+\frac{1}{2}$ ;  $\frac{1}{2}, \frac{1}{2}-u, \frac{1}{2}-u$ ;  
 $\frac{1}{2}-u, \frac{1}{2}, u+\frac{1}{2}$ ;  $u+\frac{1}{2}, \frac{1}{2}, \frac{1}{2}-u$ ;  $u+\frac{1}{2}, \frac{1}{2}, u+\frac{1}{2}$ ;  $\frac{1}{2}-u, \frac{1}{2}, \frac{1}{2}-u$ ;  
 $\bar{u}, \frac{1}{2}-u, \frac{1}{2}$ ;  $\bar{u}, u+\frac{1}{2}, \frac{1}{2}$ ;  $u+\frac{1}{2}, \frac{1}{2}-u, \frac{1}{2}$ ;  $u, u+\frac{1}{2}, \frac{1}{2}$ ;  
 $\frac{1}{2}, \bar{u}, \frac{1}{2}-u$ ;  $\frac{1}{2}, \bar{u}, u+\frac{1}{2}$ ;  $\frac{1}{2}, u+\frac{1}{2}, \frac{1}{2}-u$ ;  $\frac{1}{2}, u, u+\frac{1}{2}$ ;  
 $\frac{1}{2}-u, \frac{1}{2}, \bar{u}$ ;  $u+\frac{1}{2}, \frac{1}{2}, \bar{u}$ ;  $\frac{1}{2}-u, \frac{1}{2}, u+\frac{1}{2}$ ;  $u+\frac{1}{2}, \frac{1}{2}, u$ ;  
 $\frac{1}{2}-u, \frac{1}{2}-u, \frac{1}{2}$ ;  $\frac{1}{2}-u, u+\frac{1}{2}, \frac{1}{2}$ ;  $u, \frac{1}{2}-u, \frac{1}{2}$ ;  $u+\frac{1}{2}, u+\frac{1}{2}, \frac{1}{2}$ ;  
 $\frac{1}{2}, \frac{1}{2}-u, \frac{1}{2}-u$ ;  $\frac{1}{2}, \frac{1}{2}-u, u+\frac{1}{2}$ ;  $\frac{1}{2}, u, \frac{1}{2}-u$ ;  $\frac{1}{2}, u+\frac{1}{2}, u+\frac{1}{2}$ ;  
 $\frac{1}{2}-u, \frac{1}{2}, \frac{1}{2}-u$ ;  $u+\frac{1}{2}, \frac{1}{2}, \frac{1}{2}-u$ ;  $\frac{1}{2}-u, \frac{1}{2}, u$ ;  $u+\frac{1}{2}, \frac{1}{2}, u+\frac{1}{2}$ .

SIXTY-FOUR EQUIVALENT POSITIONS.

- (64a)  $u\ u\ u$ ;  $u\ \bar{u}\ \bar{u}$ ;  $\bar{u}\ u\ \bar{u}$ ;  $\bar{u}\ \bar{u}\ u$ ;  
 $\bar{u}\ \bar{u}\ \bar{u}$ ;  $\bar{u}\ u\ u$ ;  $u\ \bar{u}\ u$ ;  $u\ u\ \bar{u}$ ;  
 $\frac{1}{2}-u, \frac{1}{2}-u, \frac{1}{2}-u$ ;  $\frac{1}{2}-u, u+\frac{1}{2}, u+\frac{1}{2}$ ;  $u+\frac{1}{2}, \frac{1}{2}-u, u+\frac{1}{2}$ ;  
 $u+\frac{1}{2}, u+\frac{1}{2}, \frac{1}{2}-u$ ;  
 $u+\frac{1}{2}, u+\frac{1}{2}, u+\frac{1}{2}$ ;  $u+\frac{1}{2}, \frac{1}{2}-u, \frac{1}{2}-u$ ;  $\frac{1}{2}-u, u+\frac{1}{2}, \frac{1}{2}-u$ ;  
 $\frac{1}{2}-u, \frac{1}{2}-u, u+\frac{1}{2}$ ;  
 $u+\frac{1}{2}, u+\frac{1}{2}, u$ ;  $u+\frac{1}{2}, \frac{1}{2}-u, \bar{u}$ ;  $\frac{1}{2}-u, u+\frac{1}{2}, \bar{u}$ ;  $\frac{1}{2}-u, \frac{1}{2}-u, u$ ;  
 $\frac{1}{2}-u, \frac{1}{2}-u, \bar{u}$ ;  $\frac{1}{2}-u, u+\frac{1}{2}, u$ ;  $u+\frac{1}{2}, \frac{1}{2}-u, u$ ;  $u+\frac{1}{2}, u+\frac{1}{2}, \bar{u}$ ;  
 $\bar{u}, \bar{u}, \frac{1}{2}-u$ ;  $\bar{u}, u, u+\frac{1}{2}$ ;  $u, \bar{u}, u+\frac{1}{2}$ ;  $u, u, \frac{1}{2}-u$ ;  
 $u, u, u+\frac{1}{2}$ ;  $u, \bar{u}, \frac{1}{2}-u$ ;  $\bar{u}, u, \frac{1}{2}-u$ ;  $\bar{u}, \bar{u}, u+\frac{1}{2}$ ;  
 $u+\frac{1}{2}, u, u+\frac{1}{2}$ ;  $u+\frac{1}{2}, \bar{u}, \frac{1}{2}-u$ ;  $\frac{1}{2}-u, u, \frac{1}{2}-u$ ;  $\frac{1}{2}-u, \bar{u}, u+\frac{1}{2}$ ;  
 $\frac{1}{2}-u, \bar{u}, \frac{1}{2}-u$ ;  $\frac{1}{2}-u, u, u+\frac{1}{2}$ ;  $u+\frac{1}{2}, \bar{u}, u+\frac{1}{2}$ ;  $u+\frac{1}{2}, u, \frac{1}{2}-u$ ;  
 $\bar{u}, \frac{1}{2}-u, \bar{u}$ ;  $\bar{u}, u+\frac{1}{2}, u$ ;  $u, \frac{1}{2}-u, u$ ;  $u, u+\frac{1}{2}, \bar{u}$ ;  
 $u, u+\frac{1}{2}, u$ ;  $u, \frac{1}{2}-u, \bar{u}$ ;  $\bar{u}, u+\frac{1}{2}, \bar{u}$ ;  $\bar{u}, \frac{1}{2}-u, u$ ;  
 $u, u+\frac{1}{2}, u+\frac{1}{2}$ ;  $u, \frac{1}{2}-u, \frac{1}{2}-u$ ;  $\bar{u}, u+\frac{1}{2}, \frac{1}{2}-u$ ;  $\bar{u}, \frac{1}{2}-u, u+\frac{1}{2}$ ;  
 $\bar{u}, \frac{1}{2}-u, \frac{1}{2}-u$ ;  $\bar{u}, u+\frac{1}{2}, u+\frac{1}{2}$ ;  $u, \frac{1}{2}-u, u+\frac{1}{2}$ ;  $u, u+\frac{1}{2}, \frac{1}{2}-u$ ;  
 $\frac{1}{2}-u, \bar{u}, \bar{u}$ ;  $\frac{1}{2}-u, u, u$ ;  $u+\frac{1}{2}, \bar{u}, u$ ;  $u+\frac{1}{2}, u, \bar{u}$ ;  
 $u+\frac{1}{2}, u, u$ ;  $u+\frac{1}{2}, \bar{u}, \bar{u}$ ;  $\frac{1}{2}-u, u, \bar{u}$ ;  $\frac{1}{2}-u, \bar{u}, u$ .



SIXTY-FOUR EQUIVALENT POSITIONS.—*Continued.*

- (64b)  $u u u$ ;  $u \bar{u} \bar{u}$ ;  $\bar{u} u \bar{u}$ ;  $\bar{u} \bar{u} u$ ;  
 $\frac{1}{2}-u, \frac{1}{2}-u, \frac{1}{2}-u$ ;  $u+\frac{1}{2}, \frac{1}{2}-u, u+\frac{1}{2}$ ;  $\frac{1}{2}-u, u+\frac{1}{2}, u+\frac{1}{2}$ ;  
 $u+\frac{1}{2}, u+\frac{1}{2}, \frac{1}{2}-u$ ;  
 $\frac{2}{3}-u, \frac{2}{3}-u, \frac{2}{3}-u$ ;  $\frac{2}{3}-u, u+\frac{2}{3}, u+\frac{2}{3}$ ;  $u+\frac{2}{3}, \frac{2}{3}-u, u+\frac{2}{3}$ ;  
 $u+\frac{2}{3}, u+\frac{2}{3}, \frac{2}{3}-u$ ;  
 $u+\frac{1}{3}, u+\frac{1}{3}, u+\frac{1}{3}$ ;  $\frac{1}{3}-u, u+\frac{1}{3}, \frac{1}{3}-u$ ;  $u+\frac{1}{3}, \frac{1}{3}-u, \frac{1}{3}-u$ ;  
 $\frac{1}{3}-u, \frac{1}{3}-u, u+\frac{1}{3}$ ;  
 $u+\frac{1}{3}, u+\frac{1}{3}, u$ ;  $u+\frac{1}{3}, \frac{1}{3}-u, \bar{u}$ ;  $\frac{1}{3}-u, u+\frac{1}{3}, \bar{u}$ ;  $\frac{1}{3}-u, \frac{1}{3}-u, u$ ;  
 $\frac{2}{3}-u, \frac{2}{3}-u, \frac{1}{2}-u$ ;  $u+\frac{2}{3}, \frac{2}{3}-u, u+\frac{1}{2}$ ;  $\frac{2}{3}-u, u+\frac{2}{3}, u+\frac{1}{2}$ ;  
 $u+\frac{2}{3}, u+\frac{2}{3}, \frac{1}{2}-u$ ;  
 $\frac{1}{2}-u, \frac{1}{2}-u, \frac{2}{3}-u$ ;  $\frac{1}{2}-u, u+\frac{1}{2}, u+\frac{2}{3}$ ;  $u+\frac{1}{2}, \frac{1}{2}-u, u+\frac{2}{3}$ ;  
 $u+\frac{1}{2}, u+\frac{1}{2}, \frac{2}{3}-u$ ;  
 $u, u, u+\frac{1}{2}$ ;  $\bar{u}, u, \frac{1}{2}-u$ ;  $u, \bar{u}, \frac{1}{2}-u$ ;  $\bar{u}, \bar{u}, u+\frac{1}{2}$ ;  
 $u+\frac{1}{2}, u, u+\frac{1}{2}$ ;  $u+\frac{1}{2}, \bar{u}, \frac{1}{2}-u$ ;  $\frac{1}{2}-u, u, \frac{1}{2}-u$ ;  $\frac{1}{2}-u, \bar{u}, u+\frac{1}{2}$ ;  
 $\frac{2}{3}-u, \frac{1}{2}-u, \frac{2}{3}-u$ ;  $u+\frac{2}{3}, \frac{1}{2}-u, u+\frac{2}{3}$ ;  $\frac{2}{3}-u, u+\frac{1}{2}, u+\frac{2}{3}$ ;  
 $u+\frac{2}{3}, u+\frac{1}{2}, \frac{2}{3}-u$ ;  
 $\frac{1}{2}-u, \frac{2}{3}-u, \frac{1}{2}-u$ ;  $\frac{1}{2}-u, u+\frac{2}{3}, u+\frac{1}{2}$ ;  $u+\frac{1}{2}, \frac{2}{3}-u, u+\frac{1}{2}$ ;  
 $u+\frac{1}{2}, u+\frac{2}{3}, \frac{1}{2}-u$ ;  
 $u, u+\frac{1}{2}, u$ ;  $\bar{u}, u+\frac{1}{2}, \bar{u}$ ;  $u, \frac{1}{2}-u, \bar{u}$ ;  $\bar{u}, \frac{1}{2}-u, u$ ;  
 $u, u+\frac{1}{2}, u+\frac{1}{2}$ ;  $u, \frac{1}{2}-u, \frac{1}{2}-u$ ;  $\bar{u}, u+\frac{1}{2}, \frac{1}{2}-u$ ;  $\bar{u}, \frac{1}{2}-u, u+\frac{1}{2}$ ;  
 $\frac{1}{2}-u, \frac{2}{3}-u, \frac{2}{3}-u$ ;  $u+\frac{1}{2}, \frac{2}{3}-u, u+\frac{2}{3}$ ;  $\frac{1}{2}-u, u+\frac{2}{3}, u+\frac{2}{3}$ ;  
 $u+\frac{1}{2}, u+\frac{2}{3}, \frac{2}{3}-u$ ;  
 $\frac{2}{3}-u, \frac{1}{2}-u, \frac{1}{2}-u$ ;  $\frac{2}{3}-u, u+\frac{1}{2}, u+\frac{1}{2}$ ;  $u+\frac{2}{3}, \frac{1}{2}-u, u+\frac{1}{2}$ ;  
 $u+\frac{2}{3}, u+\frac{1}{2}, \frac{1}{2}-u$ ;  
 $u+\frac{1}{2}, u, u$ ;  $\frac{1}{2}-u, u, \bar{u}$ ;  $u+\frac{1}{2}, \bar{u}, \bar{u}$ ;  $\frac{1}{2}-u, \bar{u}, u$ .

NINETY-SIX EQUIVALENT POSITIONS.

- (96a)  $0 u v$ ;  $0 \bar{u} \bar{v}$ ;  $0 u \bar{v}$ ;  $0 \bar{u} v$ ;  
 $v 0 u$ ;  $\bar{v} 0 \bar{u}$ ;  $\bar{v} 0 u$ ;  $v 0 \bar{u}$ ;  
 $u v 0$ ;  $\bar{u} \bar{v} 0$ ;  $u \bar{v} 0$ ;  $\bar{u} v 0$ ;  
 $\bar{u} 0 \bar{v}$ ;  $u 0 v$ ;  $\bar{u} 0 v$ ;  $u 0 \bar{v}$ ;  
 $0 \bar{v} \bar{u}$ ;  $0 v u$ ;  $0 v \bar{u}$ ;  $0 \bar{v} u$ ;  
 $\bar{v} \bar{u} 0$ ;  $v u 0$ ;  $v \bar{u} 0$ ;  $\bar{v} u 0$ ;  
 $\frac{1}{2}, u+\frac{1}{2}, v$ ;  $\frac{1}{2}, \frac{1}{2}-u, \bar{v}$ ;  $\frac{1}{2}, u+\frac{1}{2}, \bar{v}$ ;  $\frac{1}{2}, \frac{1}{2}-u, v$ ;  
 $v+\frac{1}{2}, \frac{1}{2}, u$ ;  $\frac{1}{2}-v, \frac{1}{2}, \bar{u}$ ;  $\frac{1}{2}-v, \frac{1}{2}, u$ ;  $v+\frac{1}{2}, \frac{1}{2}, \bar{u}$ ;  
 $u+\frac{1}{2}, v+\frac{1}{2}, 0$ ;  $\frac{1}{2}-u, \frac{1}{2}-v, 0$ ;  $u+\frac{1}{2}, \frac{1}{2}-v, 0$ ;  $\frac{1}{2}-u, v+\frac{1}{2}, 0$ ;  
 $\frac{1}{2}-u, \frac{1}{2}, \bar{v}$ ;  $u+\frac{1}{2}, \frac{1}{2}, v$ ;  $\frac{1}{2}-u, \frac{1}{2}, v$ ;  $u+\frac{1}{2}, 0, \bar{v}$ ;  
 $\frac{1}{2}, \frac{1}{2}-v, \bar{u}$ ;  $\frac{1}{2}, v+\frac{1}{2}, u$ ;  $\frac{1}{2}, v+\frac{1}{2}, \bar{u}$ ;  $\frac{1}{2}, \frac{1}{2}-v, u$ ;  
 $\frac{1}{2}-v, \frac{1}{2}-u, 0$ ;  $v+\frac{1}{2}, u+\frac{1}{2}, 0$ ;  $v+\frac{1}{2}, \frac{1}{2}-u, 0$ ;  $\frac{1}{2}-v, u+\frac{1}{2}, 0$ ;  
 $\frac{1}{2}, u, v+\frac{1}{2}$ ;  $\frac{1}{2}, \bar{u}, \frac{1}{2}-v$ ;  $\frac{1}{2}, u, \frac{1}{2}-v$ ;  $\frac{1}{2}, \bar{u}, v+\frac{1}{2}$ ;  
 $v+\frac{1}{2}, 0, u+\frac{1}{2}$ ;  $\frac{1}{2}-v, 0, \frac{1}{2}-u$ ;  $\frac{1}{2}-v, 0, u+\frac{1}{2}$ ;  $v+\frac{1}{2}, 0, \frac{1}{2}-u$ ;  
 $u+\frac{1}{2}, v, \frac{1}{2}$ ;  $\frac{1}{2}-u, \bar{v}, \frac{1}{2}$ ;  $u+\frac{1}{2}, \bar{v}, \frac{1}{2}$ ;  $\frac{1}{2}-u, v, \frac{1}{2}$ ;  
 $\frac{1}{2}-u, 0, \frac{1}{2}-v$ ;  $u+\frac{1}{2}, 0, v+\frac{1}{2}$ ;  $\frac{1}{2}-u, 0, v+\frac{1}{2}$ ;  $u+\frac{1}{2}, 0, \frac{1}{2}-v$ ;  
 $\frac{1}{2}, \bar{v}, \frac{1}{2}-u$ ;  $\frac{1}{2}, v, u+\frac{1}{2}$ ;  $\frac{1}{2}, v, \frac{1}{2}-u$ ;  $\frac{1}{2}, \bar{v}, u+\frac{1}{2}$ ;

NINETY-SIX EQUIVALENT POSITIONS.—*Continued.*

- $\frac{1}{2}-v, \bar{u}, \frac{1}{2}; v+\frac{1}{2}, u, \frac{1}{2}; v+\frac{1}{2}, \bar{u}, \frac{1}{2}; \frac{1}{2}-v, u, \frac{1}{2};$   
 $0, u+\frac{1}{2}, v+\frac{1}{2}; 0, \frac{1}{2}-u, \frac{1}{2}-v; 0, u+\frac{1}{2}, \frac{1}{2}-v; 0, \frac{1}{2}-u, v+\frac{1}{2};$   
 $v, \frac{1}{2}, u+\frac{1}{2}; \bar{v}, \frac{1}{2}, \frac{1}{2}-u; \bar{v}, \frac{1}{2}, u+\frac{1}{2}; v, \frac{1}{2}, \frac{1}{2}-u;$   
 $u, v+\frac{1}{2}, \frac{1}{2}; \bar{u}, \frac{1}{2}-v, \frac{1}{2}; u, \frac{1}{2}-v, \frac{1}{2}; \bar{u}, v+\frac{1}{2}, \frac{1}{2};$   
 $\bar{u}, \frac{1}{2}, \frac{1}{2}-v; u, \frac{1}{2}, v+\frac{1}{2}; \bar{u}, \frac{1}{2}, v+\frac{1}{2}; u, \frac{1}{2}, \frac{1}{2}-v;$   
 $0, \frac{1}{2}-v, \frac{1}{2}-u; 0, v+\frac{1}{2}, u+\frac{1}{2}; 0, v+\frac{1}{2}, \frac{1}{2}-u; 0, \frac{1}{2}-v, u+\frac{1}{2};$   
 $\bar{v}, \frac{1}{2}-u, \frac{1}{2}; v, u+\frac{1}{2}, \frac{1}{2}; v, \frac{1}{2}-u, \frac{1}{2}; \bar{v}, u+\frac{1}{2}, \frac{1}{2}.$
- (96b)  $uu\bar{v}; u\bar{u}\bar{v}; \bar{u}u\bar{v}; \bar{u}\bar{u}v;$   
 $vuu; \bar{v}u\bar{u}; \bar{v}\bar{u}u; v\bar{u}\bar{u};$   
 $uvu; \bar{u}\bar{v}u; u\bar{v}\bar{u}; \bar{u}v\bar{u};$   
 $\bar{u}\bar{u}\bar{v}; u\bar{u}v; \bar{u}uv; uu\bar{v};$   
 $\bar{u}\bar{v}\bar{u}; \bar{u}vu; uv\bar{u}; u\bar{v}u;$   
 $\bar{v}\bar{u}\bar{u}; v\bar{u}\bar{u}; v\bar{u}u; \bar{v}uu;$   
 $u+\frac{1}{2}, u+\frac{1}{2}, v; u+\frac{1}{2}, \frac{1}{2}-u, \bar{v}; \frac{1}{2}-u, u+\frac{1}{2}, \bar{v}; \frac{1}{2}-u, \frac{1}{2}-u, v;$   
 $v+\frac{1}{2}, u+\frac{1}{2}, u; \frac{1}{2}-v, u+\frac{1}{2}, \bar{u}; \frac{1}{2}-v, \frac{1}{2}-u, u; v+\frac{1}{2}, \frac{1}{2}-u, \bar{u};$   
 $u+\frac{1}{2}, v+\frac{1}{2}, u; \frac{1}{2}-u, \frac{1}{2}-v, u; u+\frac{1}{2}, \frac{1}{2}-v, \bar{u}; \frac{1}{2}-u, v+\frac{1}{2}, \bar{u};$   
 $\frac{1}{2}-u, \frac{1}{2}-u, \bar{v}; u+\frac{1}{2}, \frac{1}{2}-u, v; \frac{1}{2}-u, u+\frac{1}{2}, v; u+\frac{1}{2}, u+\frac{1}{2}, \bar{v};$   
 $\frac{1}{2}-u, \frac{1}{2}-v, \bar{u}; \frac{1}{2}-u, v+\frac{1}{2}, u; u+\frac{1}{2}, v+\frac{1}{2}, \bar{u}; u+\frac{1}{2}, \frac{1}{2}-v, u;$   
 $\frac{1}{2}-v, \frac{1}{2}-u, \bar{u}; v+\frac{1}{2}, u+\frac{1}{2}, \bar{u}; v+\frac{1}{2}, \frac{1}{2}-u, u; \frac{1}{2}-v, u+\frac{1}{2}, u;$   
 $u+\frac{1}{2}, u, v+\frac{1}{2}; u+\frac{1}{2}, \bar{u}, \frac{1}{2}-v; \frac{1}{2}-u, u, \frac{1}{2}-v; \frac{1}{2}-u, \bar{u}, v+\frac{1}{2};$   
 $v+\frac{1}{2}, u, u+\frac{1}{2}; \frac{1}{2}-v, u, \frac{1}{2}-u; \frac{1}{2}-v, \bar{u}, u+\frac{1}{2}; v+\frac{1}{2}, \bar{u}, \frac{1}{2}-u;$   
 $u+\frac{1}{2}, v, u+\frac{1}{2}; \frac{1}{2}-u, \bar{v}, u+\frac{1}{2}; u+\frac{1}{2}, \bar{v}, \frac{1}{2}-u; \frac{1}{2}-u, v, \frac{1}{2}-u;$   
 $\frac{1}{2}-u, \bar{u}, \frac{1}{2}-v; u+\frac{1}{2}, \bar{u}, v+\frac{1}{2}; \frac{1}{2}-u, u, v+\frac{1}{2}; u+\frac{1}{2}, u, \frac{1}{2}-v;$   
 $\frac{1}{2}-u, \bar{v}, \frac{1}{2}-u; \frac{1}{2}-u, v, u+\frac{1}{2}; u+\frac{1}{2}, v, \frac{1}{2}-u; u+\frac{1}{2}, \bar{v}, u+\frac{1}{2};$   
 $\frac{1}{2}-v, \bar{u}, \frac{1}{2}-u; v+\frac{1}{2}, u, \frac{1}{2}-u; v+\frac{1}{2}, \bar{u}, u+\frac{1}{2}; \frac{1}{2}-v, u, u+\frac{1}{2};$   
 $u, u+\frac{1}{2}, v+\frac{1}{2}; u, \frac{1}{2}-u, \frac{1}{2}-v; \bar{u}, u+\frac{1}{2}, \frac{1}{2}-v; \bar{u}, \frac{1}{2}-u, v+\frac{1}{2};$   
 $v, u+\frac{1}{2}, u+\frac{1}{2}; \bar{v}, u+\frac{1}{2}, \frac{1}{2}-u; \bar{v}, \frac{1}{2}-u, u+\frac{1}{2}; v, \frac{1}{2}-u, \frac{1}{2}-u;$   
 $u, v+\frac{1}{2}, u+\frac{1}{2}; \bar{u}, \frac{1}{2}-v, u+\frac{1}{2}; u, \frac{1}{2}-v, \frac{1}{2}-u; \bar{u}, v+\frac{1}{2}, \frac{1}{2}-u;$   
 $\bar{u}, \frac{1}{2}-u, \frac{1}{2}-v; u, \frac{1}{2}-u, v+\frac{1}{2}; \bar{u}, u+\frac{1}{2}, v+\frac{1}{2}; u, u+\frac{1}{2}, \frac{1}{2}-v;$   
 $\bar{u}, \frac{1}{2}-v, \frac{1}{2}-u; \bar{u}, v+\frac{1}{2}, u+\frac{1}{2}; u, v+\frac{1}{2}, \frac{1}{2}-u; u, \frac{1}{2}-v, u+\frac{1}{2};$   
 $\bar{v}, \frac{1}{2}-u, \frac{1}{2}-u; v, u+\frac{1}{2}, \frac{1}{2}-u; v, \frac{1}{2}-u, u+\frac{1}{2}; \bar{v}, u+\frac{1}{2}, u+\frac{1}{2};$
- (96c)  $uu0; u+\frac{1}{2}, u, \frac{1}{2}; u\bar{u}0; u+\frac{1}{2}, \bar{u}, \frac{1}{2};$   
 $0uu; \frac{1}{2}, u, u+\frac{1}{2}; 0u\bar{u}; \frac{1}{2}, u, \frac{1}{2}-u;$   
 $u0u; u+\frac{1}{2}, 0, u+\frac{1}{2}; \bar{u}0u; \frac{1}{2}-u, 0, u+\frac{1}{2};$   
 $\bar{u}\bar{u}0; \frac{1}{2}-u, \bar{u}, \frac{1}{2}; \bar{u}u0; \frac{1}{2}-u, u, \frac{1}{2};$   
 $\bar{u}0\bar{u}; \frac{1}{2}-u, 0, \frac{1}{2}-u; 0\bar{u}u; \frac{1}{2}, \bar{u}, u+\frac{1}{2};$   
 $0\bar{u}\bar{u}; \frac{1}{2}, \bar{u}, \frac{1}{2}-u; u0\bar{u}; u+\frac{1}{2}, 0, \frac{1}{2}-u;$   
 $\frac{1}{2}-u, \frac{1}{2}-u, \frac{1}{2}; \bar{u}, \frac{1}{2}-u, 0; \frac{1}{2}-u, u+\frac{1}{2}, \frac{1}{2}; \bar{u}, u+\frac{1}{2}, 0;$   
 $\frac{1}{2}, \frac{1}{2}-u, \frac{1}{2}-u; 0, \frac{1}{2}-u, \bar{u}; \frac{1}{2}, \frac{1}{2}-u, u+\frac{1}{2}; 0, \frac{1}{2}-u, u;$   
 $\frac{1}{2}-u, \frac{1}{2}, \frac{1}{2}-u; \bar{u}\frac{1}{2}\bar{u}; u+\frac{1}{2}, \frac{1}{2}, \frac{1}{2}-u; u\frac{1}{2}\bar{u};$   
 $u+\frac{1}{2}, u+\frac{1}{2}, \frac{1}{2}; u, u+\frac{1}{2}, 0; u+\frac{1}{2}, \frac{1}{2}-u, \frac{1}{2}; u, \frac{1}{2}-u, 0;$   
 $u+\frac{1}{2}, \frac{1}{2}, u+\frac{1}{2}; u\frac{1}{2}u; \frac{1}{2}, u+\frac{1}{2}, \frac{1}{2}-u; 0, u+\frac{1}{2}, \bar{u};$   
 $\frac{1}{2}, u+\frac{1}{2}, u+\frac{1}{2}; 0, u+\frac{1}{2}, u; \frac{1}{2}-u, \frac{1}{2}, u+\frac{1}{2}; \bar{u}\frac{1}{2}u;$

NINETY-SIX EQUIVALENT POSITIONS.—Continued.

- |       |  |  |  |  |
|-------|--|--|--|--|
|       | $u + \frac{1}{2}, u + \frac{1}{2}, 0;$               | $u, u + \frac{1}{2}, \frac{1}{2};$                   | $u + \frac{1}{2}, \frac{1}{2} - u, 0;$               | $u, \frac{1}{2} - u, \frac{1}{2};$                   |
|       | $\frac{1}{2}, u + \frac{1}{2}, u;$                   | $0, u + \frac{1}{2}, u + \frac{1}{2};$               | $\frac{1}{2}, u + \frac{1}{2}, \bar{u};$             | $0, u + \frac{1}{2}, \frac{1}{2} - u;$               |
|       | $u + \frac{1}{2}, \frac{1}{2}, u;$                   | $u, \frac{1}{2}, u + \frac{1}{2};$                   | $\frac{1}{2} - u, \frac{1}{2}, u;$                   | $\bar{u}, \frac{1}{2}, u + \frac{1}{2};$             |
|       | $\frac{1}{2} - u, \frac{1}{2} - u, 0;$               | $\bar{u}, \frac{1}{2} - u, \frac{1}{2};$             | $\frac{1}{2} - u, u + \frac{1}{2}, 0;$               | $\bar{u}, u + \frac{1}{2}, \frac{1}{2};$             |
|       | $\frac{1}{2} - u, \frac{1}{2}, \bar{u};$             | $\bar{u}, \frac{1}{2}, \frac{1}{2} - u;$             | $\frac{1}{2}, \frac{1}{2} - u, u;$                   | $0, \frac{1}{2} - u, u + \frac{1}{2};$               |
|       | $\frac{1}{2}, \frac{1}{2} - u, \bar{u};$             | $0, \frac{1}{2} - u, \frac{1}{2} - u;$               | $u + \frac{1}{2}, \frac{1}{2}, \bar{u};$             | $u, \frac{1}{2}, \frac{1}{2} - u;$                   |
|       | $\bar{u} \bar{u} \frac{1}{2};$                       | $\frac{1}{2} - u, \bar{u}, 0;$                       | $\bar{u} u \frac{1}{2};$                             | $\frac{1}{2} - u, u, 0;$                             |
|       | $0, \bar{u}, \frac{1}{2} - u;$                       | $\frac{1}{2} \bar{u} \bar{u};$                       | $0, \bar{u}, u + \frac{1}{2};$                       | $\frac{1}{2} \bar{u} u;$                             |
|       | $\bar{u}, 0, \frac{1}{2} - u;$                       | $\frac{1}{2} - u, 0, \bar{u};$                       | $u, 0, \frac{1}{2} - u;$                             | $u + \frac{1}{2}, 0, \bar{u};$                       |
|       | $u u \frac{1}{2};$                                   | $u + \frac{1}{2}, u, 0;$                             | $u \bar{u} \frac{1}{2};$                             | $u + \frac{1}{2}, \bar{u}, 0;$                       |
|       | $u, 0, u + \frac{1}{2};$                             | $u + \frac{1}{2}, 0, u;$                             | $0, u, \frac{1}{2} - u;$                             | $\frac{1}{2} u \bar{u};$                             |
|       | $0, u, u + \frac{1}{2};$                             | $\frac{1}{2} u u;$                                   | $\bar{u}, 0, u + \frac{1}{2};$                       | $\frac{1}{2} - u, 0, u.$                             |
| (96d) | $u v \frac{1}{2};$                                   | $\frac{1}{2} - u, \frac{1}{2} - v, \frac{1}{2};$     | $\frac{1}{2}, u + \frac{1}{2}, v;$                   | $\frac{1}{2}, u, \frac{1}{2} - v;$                   |
|       | $\frac{1}{2} u v;$                                   | $\frac{1}{2}, \frac{1}{2} - u, \frac{1}{2} - v;$     | $v + \frac{1}{2}, \frac{1}{2}, u;$                   | $\bar{v}, \frac{1}{2}, u + \frac{1}{2};$             |
|       | $v \frac{1}{2} u;$                                   | $\frac{1}{2} - v, \frac{1}{2}, \frac{1}{2} - u;$     | $\frac{1}{2} - u, \frac{1}{2}, \bar{v};$             | $\bar{u}, \frac{1}{2}, v + \frac{1}{2};$             |
|       | $\bar{v} \bar{u} \frac{1}{2};$                       | $v + \frac{1}{2}, u + \frac{1}{2}, \frac{1}{2};$     | $\frac{1}{2}, \frac{1}{2} - v, \bar{u};$             | $\frac{1}{2}, v, \frac{1}{2} - u;$                   |
|       | $\bar{u} \frac{1}{2} \bar{v};$                       | $u + \frac{1}{2}, \frac{1}{2}, v + \frac{1}{2};$     | $\frac{1}{2}, u + \frac{1}{2}, \bar{v};$             | $\frac{1}{2}, u, v + \frac{1}{2};$                   |
|       | $\frac{1}{2} \bar{v} \bar{u};$                       | $\frac{1}{2}, v + \frac{1}{2}, u + \frac{1}{2};$     | $\frac{1}{2} - v, \frac{1}{2}, u;$                   | $v, \frac{1}{2}, u + \frac{1}{2};$                   |
|       | $u \bar{v} \frac{1}{2};$                             | $\frac{1}{2} - u, v + \frac{1}{2}, \frac{1}{2};$     | $\frac{1}{2} - u, \frac{1}{2}, v;$                   | $\bar{u}, \frac{1}{2}, \frac{1}{2} - v;$             |
|       | $\frac{1}{2} u \bar{v};$                             | $\frac{1}{2}, \frac{1}{2} - u, v + \frac{1}{2};$     | $\frac{1}{2}, v + \frac{1}{2}, \bar{u};$             | $\frac{1}{2}, \bar{v}, \frac{1}{2} - u;$             |
|       | $\bar{v} \frac{1}{2} u;$                             | $v + \frac{1}{2}, \frac{1}{2}, \frac{1}{2} - u;$     | $\frac{1}{2}, \frac{1}{2} - u, v;$                   | $u + \frac{1}{2}, v, \frac{1}{2};$                   |
|       | $v \bar{u} \frac{1}{2};$                             | $\frac{1}{2} - v, u + \frac{1}{2}, \frac{1}{2};$     | $v + \frac{1}{2}, \frac{1}{2}, \bar{u};$             | $\frac{1}{2} - v, \bar{u}, \frac{1}{2};$             |
|       | $\bar{u} \frac{1}{2} v;$                             | $u + \frac{1}{2}, \frac{1}{2}, \frac{1}{2} - v;$     | $u + \frac{1}{2}, \frac{1}{2}, \bar{v};$             | $u + \frac{1}{2}, \bar{v}, \frac{1}{2};$             |
|       | $\frac{1}{2} v \bar{u};$                             | $\frac{1}{2}, \frac{1}{2} - v, u + \frac{1}{2};$     | $\frac{1}{2}, \frac{1}{2} - v, u;$                   | $v + \frac{1}{2}, \bar{u}, \frac{1}{2};$             |
|       | $\bar{u} v \frac{1}{2};$                             | $u + \frac{1}{2}, \frac{1}{2} - v, \frac{1}{2};$     | $\frac{1}{2}, \frac{1}{2} - u, \bar{v};$             | $\frac{1}{2} - u, v, \frac{1}{2};$                   |
|       | $\frac{1}{2} \bar{u} v;$                             | $\frac{1}{2}, u + \frac{1}{2}, \frac{1}{2} - v;$     | $\frac{1}{2} - v, \frac{1}{2}, \bar{u};$             | $\frac{1}{2} - v, u, \frac{1}{2};$                   |
|       | $v \frac{1}{2} \bar{u};$                             | $\frac{1}{2} - v, \frac{1}{2}, u + \frac{1}{2};$     | $u + \frac{1}{2}, \frac{1}{2}, v;$                   | $\frac{1}{2} - u, \bar{v}, \frac{1}{2};$             |
|       | $\bar{v} u \frac{1}{2};$                             | $v + \frac{1}{2}, \frac{1}{2} - u, \frac{1}{2};$     | $\frac{1}{2}, v + \frac{1}{2}, u;$                   | $v + \frac{1}{2}, u, \frac{1}{2};$                   |
|       | $u \frac{1}{2} \bar{v};$                             | $\frac{1}{2} - u, \frac{1}{2}, v + \frac{1}{2};$     | $\frac{1}{2}, \bar{u}, \frac{1}{2} - v;$             | $\bar{u}, \frac{1}{2} - v, \frac{1}{2};$             |
|       | $\frac{1}{2} \bar{v} u;$                             | $\frac{1}{2}, v + \frac{1}{2}, \frac{1}{2} - u;$     | $\bar{v}, \frac{1}{2}, \frac{1}{2} - u;$             | $v, u + \frac{1}{2}, \frac{1}{2};$                   |
|       | $\bar{u} \bar{v} \frac{1}{2};$                       | $u + \frac{1}{2}, v + \frac{1}{2}, \frac{1}{2};$     | $u, \frac{1}{2}, v + \frac{1}{2};$                   | $\bar{u}, v + \frac{1}{2}, \frac{1}{2};$             |
|       | $\frac{1}{2} \bar{u} \bar{v};$                       | $\frac{1}{2}, u + \frac{1}{2}, v + \frac{1}{2};$     | $\frac{1}{2}, v, u + \frac{1}{2};$                   | $\bar{v}, u + \frac{1}{2}, \frac{1}{2};$             |
|       | $\bar{v} \frac{1}{2} \bar{u};$                       | $v + \frac{1}{2}, \frac{1}{2}, u + \frac{1}{2};$     | $\frac{1}{2}, \bar{u}, v + \frac{1}{2};$             | $u, \frac{1}{2} - v, \frac{1}{2};$                   |
|       | $v u \frac{1}{2};$                                   | $\frac{1}{2} - v, \frac{1}{2} - u, \frac{1}{2};$     | $v, \frac{1}{2}, \frac{1}{2} - u;$                   | $v, \frac{1}{2} - u, \frac{1}{2};$                   |
|       | $u \frac{1}{2} v;$                                   | $\frac{1}{2} - u, \frac{1}{2}, \frac{1}{2} - v;$     | $u, \frac{1}{2}, \frac{1}{2} - v;$                   | $u, v + \frac{1}{2}, \frac{1}{2};$                   |
|       | $\frac{1}{2} v u;$                                   | $\frac{1}{2}, \frac{1}{2} - v, \frac{1}{2} - u;$     | $\frac{1}{2}, \bar{v}, u + \frac{1}{2};$             | $\bar{u}, \frac{1}{2} - u, \frac{1}{2}.$             |
| (96e) | $u u v;$   | $u \bar{u} \bar{v};$                                 | $\bar{u} u \bar{v};$                                 | $\bar{u} \bar{u} v;$                                 |
|       | $v u u;$   | $\bar{v} u \bar{u};$                                 | $\bar{v} \bar{u} u;$                                 | $v \bar{u} \bar{u};$                                 |
|       | $u v u;$   | $\bar{u} \bar{v} u;$                                 | $u \bar{v} \bar{u};$                                 | $\bar{u} v \bar{u};$                                 |
|       | $\frac{1}{2} - u, \frac{1}{2} - u, \frac{1}{2} - v;$ | $u + \frac{1}{2}, \frac{1}{2} - u, v + \frac{1}{2};$ | $\frac{1}{2} - u, u + \frac{1}{2}, v + \frac{1}{2};$ | $u + \frac{1}{2}, u + \frac{1}{2}, \frac{1}{2} - v;$ |
|       | $\frac{1}{2} - u, \frac{1}{2} - v, \frac{1}{2} - u;$ | $\frac{1}{2} - u, v + \frac{1}{2}, u + \frac{1}{2};$ | $u + \frac{1}{2}, v + \frac{1}{2}, \frac{1}{2} - u;$ | $u + \frac{1}{2}, \frac{1}{2} - v, u + \frac{1}{2};$ |





NINETY-SIX EQUIVALENT POSITIONS.—*Continued.*

$u, \frac{1}{2}-u, \frac{1}{2};$      $u, u+\frac{1}{2}, \frac{1}{2};$      $0, \frac{1}{2}-u, \frac{1}{2};$      $0, u+\frac{1}{2}, \frac{1}{2};$   
 $\frac{1}{2}, u+\frac{1}{2}, \frac{1}{2}-u;$      $\frac{1}{2}, u+\frac{1}{2}, u+\frac{1}{2};$      $\frac{1}{2}, \frac{1}{2}-u, \frac{1}{2}-u;$      $\frac{1}{2}, \frac{1}{2}-u, u+\frac{1}{2};$   
 $\frac{1}{2}-u, \frac{1}{2}, u+\frac{1}{2};$      $u+\frac{1}{2}, \frac{1}{2}, u+\frac{1}{2};$      $\frac{1}{2}-u, \frac{1}{2}, \frac{1}{2}-u;$      $u+\frac{1}{2}, \frac{1}{2}, \frac{1}{2}-u;$   
 $\frac{1}{2}-u, u+\frac{1}{2}, \frac{1}{2};$      $u+\frac{1}{2}, u+\frac{1}{2}, \frac{1}{2};$      $\frac{1}{2}-u, \frac{1}{2}-u, \frac{1}{2};$      $u+\frac{1}{2}, \frac{1}{2}-u, \frac{1}{2};$   
 $u+\frac{1}{2}, \frac{1}{2}, \frac{1}{2}-u;$      $u+\frac{1}{2}, \frac{1}{2}, u+\frac{1}{2};$      $\frac{1}{2}-u, \frac{1}{2}, \frac{1}{2}-u;$      $\frac{1}{2}-u, \frac{1}{2}, u+\frac{1}{2};$   
 $\frac{1}{2}, \frac{1}{2}-u, u+\frac{1}{2};$      $\frac{1}{2}, u+\frac{1}{2}, u+\frac{1}{2};$      $\frac{1}{2}, \frac{1}{2}-u, \frac{1}{2}-u;$      $\frac{1}{2}, u+\frac{1}{2}, \frac{1}{2}-u;$   
 $\frac{1}{2}-u, u, \frac{1}{2};$      $u+\frac{1}{2}, u, \frac{1}{2};$      $\frac{1}{2}-u, u, \frac{1}{2};$      $u+\frac{1}{2}, 0, \frac{1}{2};$   
 $u, \frac{1}{2}, \frac{1}{2}-u;$      $u, \frac{1}{2}, u+\frac{1}{2};$      $0, \frac{1}{2}, \frac{1}{2}-u;$      $0, \frac{1}{2}, u+\frac{1}{2};$   
 $\frac{1}{2}, \frac{1}{2}-u, u+\frac{1}{2};$      $\frac{1}{2}, u+\frac{1}{2}, u+\frac{1}{2};$      $\frac{1}{2}, \frac{1}{2}-u, \frac{1}{2}-u;$      $\frac{1}{2}, u+\frac{1}{2}, \frac{1}{2}-u;$   
 $\frac{1}{2}-u, u, \frac{1}{2};$      $u+\frac{1}{2}, u, \frac{1}{2};$      $\frac{1}{2}-u, 0, \frac{1}{2};$      $u+\frac{1}{2}, 0, \frac{1}{2};$   
 $u+\frac{1}{2}, \frac{1}{2}, \frac{1}{2}-u;$      $u+\frac{1}{2}, \frac{1}{2}, u+\frac{1}{2};$      $\frac{1}{2}-u, \frac{1}{2}, \frac{1}{2}-u;$      $\frac{1}{2}-u, \frac{1}{2}, u+\frac{1}{2};$   
 $\frac{1}{2}, \frac{1}{2}-u, u;$      $\frac{1}{2}, u+\frac{1}{2}, u;$      $\frac{1}{2}, \frac{1}{2}-u, 0;$      $\frac{1}{2}, u+\frac{1}{2}, 0;$   
 $\frac{1}{2}-u, u+\frac{1}{2}, \frac{1}{2};$      $u+\frac{1}{2}, u+\frac{1}{2}, \frac{1}{2};$      $\frac{1}{2}-u, \frac{1}{2}-u, \frac{1}{2};$      $u+\frac{1}{2}, \frac{1}{2}-u, \frac{1}{2};$   
 $u, \frac{1}{2}, \frac{1}{2}-u;$      $u, \frac{1}{2}, u+\frac{1}{2};$      $0, \frac{1}{2}, \frac{1}{2}-u;$      $0, \frac{1}{2}, u+\frac{1}{2};$   
 $\frac{1}{2}, \frac{1}{2}-u, u;$      $\frac{1}{2}, u+\frac{1}{2}, u;$      $\frac{1}{2}, \frac{1}{2}-u, 0;$      $\frac{1}{2}, u+\frac{1}{2}, 0;$

A. TETARTOEDRY.

SPACE-GROUP  $T^1$ .

One equivalent position:

(a) 1a.            (b) 1b.

Three equivalent positions:

(c) 3a.            (d) 3b.

Four equivalent positions:

(e) 4a.

Six equivalent positions:

(f) 6a.            (h) 6c.

(g) 6b.            (i) 6d.

Twelve equivalent positions:

(j)  $xyz; x\bar{y}\bar{z}; \bar{x}y\bar{z}; \bar{x}\bar{y}z;$   
 $zxy; \bar{z}x\bar{y}; \bar{z}\bar{x}y; z\bar{x}\bar{y};$   
 $yzx; \bar{y}\bar{z}x; y\bar{z}\bar{x}; \bar{y}z\bar{x}.$

SPACE-GROUP  $T^2$ .

Four equivalent positions:

(a) 4b.            (c) 4d.

(b) 4c.            (d) 4e.

Sixteen equivalent positions:

(e) 16a.

Twenty-four equivalent positions:

(f) 24a.            (g) 24b.

SPACE-GROUP  $T^3$  (continued).

Forty-eight equivalent positions:

$$\begin{aligned}
 (h) \quad &xyz; \quad x\bar{y}\bar{z}; \quad \bar{x}y\bar{z}; \quad \bar{x}\bar{y}z; \\
 &xy\bar{z}; \quad \bar{z}x\bar{y}; \quad \bar{z}\bar{x}y; \quad z\bar{x}\bar{y}; \\
 &y\bar{z}x; \quad \bar{y}\bar{z}\bar{x}; \quad y\bar{z}\bar{x}; \quad \bar{y}z\bar{x}; \\
 &x+\frac{1}{2}, y+\frac{1}{2}, z; \quad x+\frac{1}{2}, \frac{1}{2}-y, \bar{z}; \quad \frac{1}{2}-x, y+\frac{1}{2}, \bar{z}; \quad \frac{1}{2}-x, \frac{1}{2}-y, z; \\
 &z+\frac{1}{2}, x+\frac{1}{2}, y; \quad \frac{1}{2}-z, x+\frac{1}{2}, \bar{y}; \quad \frac{1}{2}-z, \frac{1}{2}-x, y; \quad z+\frac{1}{2}, \frac{1}{2}-x, \bar{y}; \\
 &y+\frac{1}{2}, z+\frac{1}{2}, x; \quad \frac{1}{2}-y, \frac{1}{2}-z, x; \quad y+\frac{1}{2}, \frac{1}{2}-z, \bar{x}; \quad \frac{1}{2}-y, z+\frac{1}{2}, \bar{x}; \\
 &x+\frac{1}{2}, y, z+\frac{1}{2}; \quad x+\frac{1}{2}, \bar{y}, \frac{1}{2}-z; \quad \frac{1}{2}-x, y, \frac{1}{2}-z; \quad \frac{1}{2}-x, \bar{y}, z+\frac{1}{2}; \\
 &z+\frac{1}{2}, x, y+\frac{1}{2}; \quad \frac{1}{2}-z, x, \frac{1}{2}-y; \quad \frac{1}{2}-z, \bar{x}, y+\frac{1}{2}; \quad z+\frac{1}{2}, \bar{x}, \frac{1}{2}-y; \\
 &y+\frac{1}{2}, z, x+\frac{1}{2}; \quad \frac{1}{2}-y, \bar{z}, x+\frac{1}{2}; \quad y+\frac{1}{2}, \bar{z}, \frac{1}{2}-x; \quad \frac{1}{2}-y, z, \frac{1}{2}-x; \\
 &x, y+\frac{1}{2}, z+\frac{1}{2}; \quad x, \frac{1}{2}-y, \frac{1}{2}-z; \quad \bar{x}, y+\frac{1}{2}, \frac{1}{2}-z; \quad \bar{x}, \frac{1}{2}-y, z+\frac{1}{2}; \\
 &z, x+\frac{1}{2}, y+\frac{1}{2}; \quad \bar{z}, x+\frac{1}{2}, \frac{1}{2}-y; \quad \bar{z}, \frac{1}{2}-x, y+\frac{1}{2}; \quad z, \frac{1}{2}-x, \frac{1}{2}-y; \\
 &y, z+\frac{1}{2}, x+\frac{1}{2}; \quad \bar{y}, \frac{1}{2}-z, x+\frac{1}{2}; \quad y, \frac{1}{2}-z, \frac{1}{2}-x; \quad \bar{y}, z+\frac{1}{2}, \frac{1}{2}-x.
 \end{aligned}$$

SPACE-GROUP  $T^3$ .

Two equivalent positions:

(a) 2a.

Six equivalent positions:

(b) 6e.

Eight equivalent positions:

(c) 8a.

Twelve equivalent positions:

(d) 12a. (e) 12b.

Twenty-four equivalent positions:

$$\begin{aligned}
 (f) \quad &xyz; \quad x\bar{y}\bar{z}; \quad \bar{x}y\bar{z}; \quad \bar{x}\bar{y}z; \\
 &xy\bar{z}; \quad \bar{z}x\bar{y}; \quad \bar{z}\bar{x}y; \quad z\bar{x}\bar{y}; \\
 &y\bar{z}x; \quad \bar{y}\bar{z}\bar{x}; \quad y\bar{z}\bar{x}; \quad \bar{y}z\bar{x}; \\
 &x+\frac{1}{2}, y+\frac{1}{2}, z+\frac{1}{2}; \quad x+\frac{1}{2}, \frac{1}{2}-y, \frac{1}{2}-z; \quad \frac{1}{2}-x, y+\frac{1}{2}, \frac{1}{2}-z; \\
 & \quad \quad \quad \quad \quad \quad \quad \quad \quad \quad \quad \quad \quad \quad \quad \quad \quad \quad \quad \frac{1}{2}-x, \frac{1}{2}-y, z+\frac{1}{2}; \\
 &z+\frac{1}{2}, x+\frac{1}{2}, y+\frac{1}{2}; \quad \frac{1}{2}-z, x+\frac{1}{2}, \frac{1}{2}-y; \quad \frac{1}{2}-z, \frac{1}{2}-x, y+\frac{1}{2}; \\
 & \quad \quad \quad \quad \quad \quad \quad \quad \quad \quad \quad \quad \quad \quad \quad \quad \quad \quad \quad z+\frac{1}{2}, \frac{1}{2}-x, \frac{1}{2}-y; \\
 &y+\frac{1}{2}, z+\frac{1}{2}, x+\frac{1}{2}; \quad \frac{1}{2}-y, \frac{1}{2}-z, x+\frac{1}{2}; \quad y+\frac{1}{2}, \frac{1}{2}-z, \frac{1}{2}-x; \\
 & \quad \quad \quad \quad \quad \quad \quad \quad \quad \quad \quad \quad \quad \quad \quad \quad \quad \quad \quad \frac{1}{2}-y, z+\frac{1}{2}, \frac{1}{2}-x.
 \end{aligned}$$

SPACE-GROUP  $T^4$ .

Four equivalent positions:

(a) 4f.

Twelve equivalent positions:

$$\begin{aligned}
 (b) \quad &xyz; \quad x+\frac{1}{2}, \frac{1}{2}-y, \bar{z}; \quad \bar{x}, y+\frac{1}{2}, \frac{1}{2}-z; \quad \frac{1}{2}-x, \bar{y}, z+\frac{1}{2}; \\
 &zxy; \quad \bar{z}, x+\frac{1}{2}, \frac{1}{2}-y; \quad \frac{1}{2}-z, \bar{x}, y+\frac{1}{2}; \quad z+\frac{1}{2}, \frac{1}{2}-x, \bar{y}; \\
 &y\bar{z}x; \quad \frac{1}{2}-y, \bar{z}, x+\frac{1}{2}; \quad y+\frac{1}{2}, \frac{1}{2}-z, \bar{x}; \quad \bar{y}, z+\frac{1}{2}, \frac{1}{2}-x.
 \end{aligned}$$

SPACE-GROUP  $T^2$ .

*Eight* equivalent positions:

(a) 8b.

*Twelve* equivalent positions:

(b) 12c.

*Twenty-four* equivalent positions:

(c)  $xyz$ ;  $x, \bar{y}, \frac{1}{2}-z$ ;  $\frac{1}{2}-x, y, \bar{z}$ ;  $\bar{x}, \frac{1}{2}-y, z$ ;  
 $zxy$ ;  $\frac{1}{2}-z, x, \bar{y}$ ;  $\bar{z}, \frac{1}{2}-x, y$ ;  $z, \bar{x}, \frac{1}{2}-y$ ;  
 $yzx$ ;  $\bar{y}, \frac{1}{2}-z, x$ ;  $y, \bar{z}, \frac{1}{2}-x$ ;  $\frac{1}{2}-y, z, \bar{x}$ ;  
 $x+\frac{1}{2}, y+\frac{1}{2}, z+\frac{1}{2}$ ;  $x+\frac{1}{2}, \frac{1}{2}-y, \bar{z}$ ;  $\bar{x}, y+\frac{1}{2}, \frac{1}{2}-z$ ;  
 $\frac{1}{2}-x, \bar{y}, z+\frac{1}{2}$ ;  
 $z+\frac{1}{2}, x+\frac{1}{2}, y+\frac{1}{2}$ ;  $\bar{z}, x+\frac{1}{2}, \frac{1}{2}-y$ ;  $\frac{1}{2}-z, \bar{x}, y+\frac{1}{2}$ ;  
 $z+\frac{1}{2}, \frac{1}{2}-x, \bar{y}$ ;  
 $y+\frac{1}{2}, z+\frac{1}{2}, x+\frac{1}{2}$ ;  $\frac{1}{2}-y, \bar{z}, x+\frac{1}{2}$ ;  $y+\frac{1}{2}, \frac{1}{2}-z, \bar{x}$ ;  
 $\bar{y}, z+\frac{1}{2}, \frac{1}{2}-x$ .

B. PARAMORPHIC HEMIHEDRY.

SPACE-GROUP  $T_2^1$ .

*One* equivalent position:

(a) 1a. (b) 1b.

*Three* equivalent positions:

(c) 3a. (d) 3b.

*Six* equivalent positions:

(e) 6a. (g) 6c.

(f) 6b. (h) 6d.

*Eight* equivalent positions:

(i) 8c.

*Twelve* equivalent positions:

(j) 12d. (k) 12e.

*Twenty-four* equivalent positions:

(l)  $xyz$ ;  $x\bar{y}\bar{z}$ ;  $\bar{x}y\bar{z}$ ;  $\bar{x}\bar{y}z$ ;  
 $zxy$ ;  $\bar{z}x\bar{y}$ ;  $\bar{z}\bar{x}y$ ;  $z\bar{x}\bar{y}$ ;  
 $yzx$ ;  $\bar{y}\bar{z}x$ ;  $y\bar{z}\bar{x}$ ;  $\bar{y}z\bar{x}$ ;  
 $\bar{x}\bar{y}\bar{z}$ ;  $\bar{x}yz$ ;  $x\bar{y}z$ ;  $xy\bar{z}$ ;  
 $\bar{z}\bar{x}\bar{y}$ ;  $z\bar{x}y$ ;  $zxy$ ;  $\bar{z}xy$ ;  
 $\bar{y}\bar{z}\bar{x}$ ;  $y\bar{z}\bar{x}$ ;  $\bar{y}zx$ ;  $y\bar{z}x$ .

SPACE-GROUP  $T_2^2$ .

*Two* equivalent positions:

(a) 2a.

*Four* equivalent positions:

(b) 4d. (c) 4e.



SPACE GROUP  $T_1^2$  (continued).

Six equivalent positions:

(d) 6e.

Eight equivalent positions:

(e) 8d.

Twelve equivalent positions:

(f) 12a. (g) 12b.

Twenty-four equivalent positions:

(h)  $xyz$ ;  $x\bar{y}\bar{z}$ ;  $\bar{x}y\bar{z}$ ;  $\bar{x}\bar{y}z$ ;  
 $zxy$ ;  $\bar{z}\bar{x}\bar{y}$ ;  $\bar{z}\bar{x}y$ ;  $z\bar{x}\bar{y}$ ;  
 $yzx$ ;  $\bar{y}\bar{z}\bar{x}$ ;  $y\bar{z}\bar{x}$ ;  $\bar{y}z\bar{x}$ ;  
 $\frac{1}{2}-x, \frac{1}{2}-y, \frac{1}{2}-z$ ;  $\frac{1}{2}-x, y+\frac{1}{2}, z+\frac{1}{2}$ ;  $x+\frac{1}{2}, \frac{1}{2}-y, z+\frac{1}{2}$ ;  
 $x+\frac{1}{2}, y+\frac{1}{2}, \frac{1}{2}-z$ ;  
 $\frac{1}{2}-z, \frac{1}{2}-x, \frac{1}{2}-y$ ;  $z+\frac{1}{2}, \frac{1}{2}-x, y+\frac{1}{2}$ ;  $z+\frac{1}{2}, x+\frac{1}{2}, \frac{1}{2}-y$ ;  
 $\frac{1}{2}-z, x+\frac{1}{2}, y+\frac{1}{2}$ ;  
 $\frac{1}{2}-y, \frac{1}{2}-z, \frac{1}{2}-x$ ;  $y+\frac{1}{2}, z+\frac{1}{2}, \frac{1}{2}-x$ ;  $\frac{1}{2}-y, z+\frac{1}{2}, x+\frac{1}{2}$ ;  
 $y+\frac{1}{2}, \frac{1}{2}-z, x+\frac{1}{2}$ .

SPACE-GROUP  $T_1^3$ .

Four equivalent positions:

(a) 4b. (b) 4c.

Eight equivalent positions:

(c) 8e.

Twenty-four equivalent positions:

(d) 24c. (e) 24a.

Thirty-two equivalent positions:

(f) 32a.

Forty-eight equivalent positions:

(g) 48a. (h) 48b.

Ninety-six equivalent positions:

(i)  $xyz$ ;  $x\bar{y}\bar{z}$ ;  $\bar{x}y\bar{z}$ ;  $\bar{x}\bar{y}z$ ;  
 $zxy$ ;  $\bar{z}\bar{x}\bar{y}$ ;  $\bar{z}\bar{x}y$ ;  $z\bar{x}\bar{y}$ ;  
 $yzx$ ;  $\bar{y}\bar{z}\bar{x}$ ;  $y\bar{z}\bar{x}$ ;  $\bar{y}z\bar{x}$ ;  
 $\bar{x}\bar{y}\bar{z}$ ;  $\bar{x}yz$ ;  $x\bar{y}z$ ;  $xy\bar{z}$ ;  
 $\bar{z}\bar{x}\bar{y}$ ;  $z\bar{x}y$ ;  $z\bar{x}\bar{y}$ ;  $\bar{z}xy$ ;  
 $\bar{y}\bar{z}\bar{x}$ ;  $y\bar{z}\bar{x}$ ;  $\bar{y}zx$ ;  $y\bar{z}x$ ;  
 $x+\frac{1}{2}, y+\frac{1}{2}, z$ ;  $x+\frac{1}{2}, \frac{1}{2}-y, \bar{z}$ ;  $\frac{1}{2}-x, y+\frac{1}{2}, \bar{z}$ ;  $\frac{1}{2}-x, \frac{1}{2}-y, z$ ;  
 $z+\frac{1}{2}, x+\frac{1}{2}, y$ ;  $\frac{1}{2}-z, x+\frac{1}{2}, \bar{y}$ ;  $\frac{1}{2}-z, \frac{1}{2}-x, y$ ;  $z+\frac{1}{2}, \frac{1}{2}-x, \bar{y}$ ;  
 $y+\frac{1}{2}, z+\frac{1}{2}, x$ ;  $\frac{1}{2}-y, \frac{1}{2}-z, x$ ;  $y+\frac{1}{2}, \frac{1}{2}-z, \bar{x}$ ;  $\frac{1}{2}-y, z+\frac{1}{2}, \bar{x}$ ;  
 $\frac{1}{2}-x, \frac{1}{2}-y, \bar{z}$ ;  $\frac{1}{2}-x, y+\frac{1}{2}, z$ ;  $x+\frac{1}{2}, \frac{1}{2}-y, z$ ;  $x+\frac{1}{2}, y+\frac{1}{2}, \bar{z}$ ;  
 $\frac{1}{2}-z, \frac{1}{2}-x, \bar{y}$ ;  $z+\frac{1}{2}, \frac{1}{2}-x, y$ ;  $z+\frac{1}{2}, x+\frac{1}{2}, \bar{y}$ ;  $\frac{1}{2}-z, x+\frac{1}{2}, y$ ;  
 $\frac{1}{2}-y, \frac{1}{2}-z, \bar{x}$ ;  $y+\frac{1}{2}, z+\frac{1}{2}, \bar{x}$ ;  $\frac{1}{2}-y, z+\frac{1}{2}, x$ ;  $y+\frac{1}{2}, \frac{1}{2}-z, x$ ;

SPACE-GROUP  $T_1^3$  (continued).

$x+\frac{1}{2}, y, z+\frac{1}{2}; x+\frac{1}{2}, \bar{y}, \frac{1}{2}-z; \frac{1}{2}-x, y, \frac{1}{2}-z; \frac{1}{2}-x, \bar{y}, z+\frac{1}{2};$   
 $z+\frac{1}{2}, x, y+\frac{1}{2}; \frac{1}{2}-z, x, \frac{1}{2}-y; \frac{1}{2}-z, \bar{x}, y+\frac{1}{2}; z+\frac{1}{2}, \bar{x}, \frac{1}{2}-y;$   
 $y+\frac{1}{2}, z, x+\frac{1}{2}; \frac{1}{2}-y, \bar{z}, x+\frac{1}{2}; y+\frac{1}{2}, \bar{z}, \frac{1}{2}-x; \frac{1}{2}-y, z, \frac{1}{2}-x;$   
 $\frac{1}{2}-x, \bar{y}, \frac{1}{2}-z; \frac{1}{2}-x, y, z+\frac{1}{2}; x+\frac{1}{2}, \bar{y}, z+\frac{1}{2}; x+\frac{1}{2}, y, \frac{1}{2}-z;$   
 $\frac{1}{2}-z, \bar{x}, \frac{1}{2}-y; z+\frac{1}{2}, \bar{x}, y+\frac{1}{2}; z+\frac{1}{2}, x, \frac{1}{2}-y; \frac{1}{2}-z, x, y+\frac{1}{2};$   
 $\frac{1}{2}-y, \bar{z}, \frac{1}{2}-x; y+\frac{1}{2}, z, \frac{1}{2}-x; \frac{1}{2}-y, z, x+\frac{1}{2}; y+\frac{1}{2}, \bar{z}, x+\frac{1}{2};$   
 $x, y+\frac{1}{2}, z+\frac{1}{2}; x, \frac{1}{2}-y, \frac{1}{2}-z; \bar{x}, y+\frac{1}{2}, \frac{1}{2}-z; \bar{x}, \frac{1}{2}-y, z+\frac{1}{2};$   
 $z, x+\frac{1}{2}, y+\frac{1}{2}; \bar{z}, x+\frac{1}{2}, \frac{1}{2}-y; \bar{z}, \frac{1}{2}-x, y+\frac{1}{2}; z, \frac{1}{2}-x, \frac{1}{2}-y;$   
 $y, z+\frac{1}{2}, x+\frac{1}{2}; \bar{y}, \frac{1}{2}-z, x+\frac{1}{2}; y, \frac{1}{2}-z, \frac{1}{2}-x; \bar{y}, z+\frac{1}{2}, \frac{1}{2}-x;$   
 $\bar{x}, \frac{1}{2}-y, \frac{1}{2}-z; \bar{x}, y+\frac{1}{2}, z+\frac{1}{2}; x, \frac{1}{2}-y, z+\frac{1}{2}; x, y+\frac{1}{2}, \frac{1}{2}-z;$   
 $\bar{z}, \frac{1}{2}-x, \frac{1}{2}-y; z, \frac{1}{2}-x, y+\frac{1}{2}; z, x+\frac{1}{2}, \frac{1}{2}-y; \bar{z}, x+\frac{1}{2}, y+\frac{1}{2};$   
 $\bar{y}, \frac{1}{2}-z, \frac{1}{2}-x; y, z+\frac{1}{2}, \frac{1}{2}-x; \bar{y}, z+\frac{1}{2}, x+\frac{1}{2}; y, \frac{1}{2}-z, x+\frac{1}{2}.$

SPACE-GROUP  $T_1^4$ .

Eight equivalent positions:

(a) 8f. (b) 8g.

Sixteen equivalent positions:

(c) 16b. (d) 16c.

Thirty-two equivalent positions:

(e) 32b.

Forty-eight equivalent positions:

(f) 48c.

Ninety-six equivalent positions:

(g)  $xyz; x\bar{y}\bar{z}; \bar{x}y\bar{z}; \bar{x}\bar{y}z;$   
 $zxy; \bar{z}x\bar{y}; \bar{z}\bar{x}y; z\bar{x}\bar{y};$   
 $yxz; \bar{y}\bar{z}x; y\bar{z}\bar{x}; \bar{y}z\bar{x};$   
 $x+\frac{1}{2}, y+\frac{1}{2}, z; x+\frac{1}{2}, \frac{1}{2}-y, \bar{z}; \frac{1}{2}-x, y+\frac{1}{2}, \bar{z}; \frac{1}{2}-x, \frac{1}{2}-y, z;$   
 $z+\frac{1}{2}, x+\frac{1}{2}, y; \frac{1}{2}-z, x+\frac{1}{2}, \bar{y}; \frac{1}{2}-z, \frac{1}{2}-x, y; z+\frac{1}{2}, \frac{1}{2}-x, \bar{y};$   
 $y+\frac{1}{2}, z+\frac{1}{2}, x; \frac{1}{2}-y, \frac{1}{2}-z, x; y+\frac{1}{2}, \frac{1}{2}-z, \bar{x}; \frac{1}{2}-y, z+\frac{1}{2}, \bar{x};$   
 $x+\frac{1}{2}, y, z+\frac{1}{2}; x+\frac{1}{2}, \bar{y}, \frac{1}{2}-z; \frac{1}{2}-x, y, \frac{1}{2}-z; \frac{1}{2}-x, \bar{y}, z+\frac{1}{2};$   
 $z+\frac{1}{2}, x, y+\frac{1}{2}; \frac{1}{2}-z, x, \frac{1}{2}-y; \frac{1}{2}-z, \bar{x}, y+\frac{1}{2}; z+\frac{1}{2}, \bar{x}, \frac{1}{2}-y;$   
 $y+\frac{1}{2}, z, x+\frac{1}{2}; \frac{1}{2}-y, \bar{z}, x+\frac{1}{2}; y+\frac{1}{2}, \bar{z}, \frac{1}{2}-x; \frac{1}{2}-y, z, \frac{1}{2}-x;$   
 $x, y+\frac{1}{2}, z+\frac{1}{2}; x, \frac{1}{2}-y, \frac{1}{2}-z; \bar{x}, y+\frac{1}{2}, \frac{1}{2}-z; \bar{x}, \frac{1}{2}-y, z+\frac{1}{2};$   
 $z, x+\frac{1}{2}, y+\frac{1}{2}; \bar{z}, x+\frac{1}{2}, \frac{1}{2}-y; \bar{z}, \frac{1}{2}-x, y+\frac{1}{2}; z, \frac{1}{2}-x, \frac{1}{2}-y;$   
 $y, z+\frac{1}{2}, x+\frac{1}{2}; \bar{y}, \frac{1}{2}-z, x+\frac{1}{2}; y, \frac{1}{2}-z, \frac{1}{2}-x; \bar{y}, z+\frac{1}{2}, \frac{1}{2}-x;$   
 $\frac{1}{2}-x, \frac{1}{2}-y, \frac{1}{2}-z; \frac{1}{2}-x, y+\frac{1}{2}, z+\frac{1}{2}; x+\frac{1}{2}, \frac{1}{2}-y, z+\frac{1}{2};$   
 $x+\frac{1}{2}, y+\frac{1}{2}, \frac{1}{2}-z;$   
 $\frac{1}{2}-z, \frac{1}{2}-x, \frac{1}{2}-y; z+\frac{1}{2}, \frac{1}{2}-x, y+\frac{1}{2}; z+\frac{1}{2}, x+\frac{1}{2}, \frac{1}{2}-y;$   
 $\frac{1}{2}-z, x+\frac{1}{2}, y+\frac{1}{2};$   
 $\frac{1}{2}-y, \frac{1}{2}-z, \frac{1}{2}-x; y+\frac{1}{2}, z+\frac{1}{2}, \frac{1}{2}-x; \frac{1}{2}-y, z+\frac{1}{2}, x+\frac{1}{2};$   
 $y+\frac{1}{2}, \frac{1}{2}-z, x+\frac{1}{2};$   
 $\frac{1}{2}-x, \frac{1}{2}-y, \frac{1}{2}-z; \frac{1}{2}-x, y+\frac{1}{2}, z+\frac{1}{2}; x+\frac{1}{2}, \frac{1}{2}-y, z+\frac{1}{2};$   
 $x+\frac{1}{2}, y+\frac{1}{2}, \frac{1}{2}-z;$

SPACE GROUP  $T_2^2$  (continued).*Six* equivalent positions:

(d) 6e.

*Eight* equivalent positions:

(e) 8d.

*Twelve* equivalent positions:

(f) 12a. (g) 12b.

*Twenty-four* equivalent positions:

(h)  $xyz; \quad x\bar{y}\bar{z}; \quad \bar{x}y\bar{z}; \quad \bar{x}\bar{y}z;$   
 $zxy; \quad \bar{z}x\bar{y}; \quad \bar{z}\bar{x}y; \quad z\bar{x}\bar{y};$   
 $yzx; \quad \bar{y}\bar{z}x; \quad y\bar{z}\bar{x}; \quad \bar{y}z\bar{x};$   
 $\frac{1}{2}-x, \frac{1}{2}-y, \frac{1}{2}-z; \quad \frac{1}{2}-x, y+\frac{1}{2}, z+\frac{1}{2}; \quad x+\frac{1}{2}, \frac{1}{2}-y, z+\frac{1}{2};$   
 $x+\frac{1}{2}, y+\frac{1}{2}, \frac{1}{2}-z;$   
 $\frac{1}{2}-z, \frac{1}{2}-x, \frac{1}{2}-y; \quad z+\frac{1}{2}, \frac{1}{2}-x, y+\frac{1}{2}; \quad z+\frac{1}{2}, x+\frac{1}{2}, \frac{1}{2}-y;$   
 $\frac{1}{2}-z, x+\frac{1}{2}, y+\frac{1}{2};$   
 $\frac{1}{2}-y, \frac{1}{2}-z, \frac{1}{2}-x; \quad y+\frac{1}{2}, z+\frac{1}{2}, \frac{1}{2}-x; \quad \frac{1}{2}-y, z+\frac{1}{2}, x+\frac{1}{2};$   
 $y+\frac{1}{2}, \frac{1}{2}-z, x+\frac{1}{2}.$

SPACE-GROUP  $T_2^3$ .*Four* equivalent positions:

(a) 4b. (b) 4c.

*Eight* equivalent positions:

(c) 8e.

*Twenty-four* equivalent positions:

(d) 24c. (e) 24a.

*Thirty-two* equivalent positions:

(f) 32a.

*Forty-eight* equivalent positions:

(g) 48a. (h) 48b.

*Ninety-six* equivalent positions:

(i)  $xyz; \quad x\bar{y}\bar{z}; \quad \bar{x}y\bar{z}; \quad \bar{x}\bar{y}z;$   
 $zxy; \quad \bar{z}x\bar{y}; \quad \bar{z}\bar{x}y; \quad z\bar{x}\bar{y};$   
 $yzx; \quad \bar{y}\bar{z}x; \quad y\bar{z}\bar{x}; \quad \bar{y}z\bar{x};$   
 $\bar{x}\bar{y}\bar{z}; \quad \bar{x}y\bar{z}; \quad x\bar{y}\bar{z}; \quad x\bar{y}z;$   
 $\bar{z}\bar{x}\bar{y}; \quad z\bar{x}y; \quad z\bar{x}\bar{y}; \quad \bar{z}x\bar{y};$   
 $\bar{y}\bar{z}\bar{x}; \quad y\bar{z}\bar{x}; \quad \bar{y}z\bar{x}; \quad y\bar{z}x;$   
 $x+\frac{1}{2}, y+\frac{1}{2}, z; \quad x+\frac{1}{2}, \frac{1}{2}-y, \bar{z}; \quad \frac{1}{2}-x, y+\frac{1}{2}, \bar{z}; \quad \frac{1}{2}-x, \frac{1}{2}-y, z;$   
 $z+\frac{1}{2}, x+\frac{1}{2}, y; \quad \frac{1}{2}-z, x+\frac{1}{2}, \bar{y}; \quad \frac{1}{2}-z, \frac{1}{2}-x, y; \quad z+\frac{1}{2}, \frac{1}{2}-x, \bar{y};$   
 $y+\frac{1}{2}, z+\frac{1}{2}, x; \quad \frac{1}{2}-y, \frac{1}{2}-z, x; \quad y+\frac{1}{2}, \frac{1}{2}-z, \bar{x}; \quad \frac{1}{2}-y, z+\frac{1}{2}, \bar{x};$   
 $\frac{1}{2}-x, \frac{1}{2}-y, \bar{z}; \quad \frac{1}{2}-x, y+\frac{1}{2}, z; \quad x+\frac{1}{2}, \frac{1}{2}-y, z; \quad x+\frac{1}{2}, y+\frac{1}{2}, \bar{z};$   
 $\frac{1}{2}-z, \frac{1}{2}-x, \bar{y}; \quad z+\frac{1}{2}, \frac{1}{2}-x, y; \quad z+\frac{1}{2}, x+\frac{1}{2}, \bar{y}; \quad \frac{1}{2}-z, x+\frac{1}{2}, y;$   
 $\frac{1}{2}-y, \frac{1}{2}-z, \bar{x}; \quad y+\frac{1}{2}, z+\frac{1}{2}, \bar{x}; \quad \frac{1}{2}-y, z+\frac{1}{2}, x; \quad y+\frac{1}{2}, \frac{1}{2}-z, x;$

SPACE-GROUP  $T_2^3$  (continued).

$x+\frac{1}{2}, y, z+\frac{1}{2}; x+\frac{1}{2}, \bar{y}, \frac{1}{2}-z; \frac{1}{2}-x, y, \frac{1}{2}-z; \frac{1}{2}-x, \bar{y}, z+\frac{1}{2};$   
 $z+\frac{1}{2}, x, y+\frac{1}{2}; \frac{1}{2}-z, x, \frac{1}{2}-y; \frac{1}{2}-z, \bar{x}, y+\frac{1}{2}; z+\frac{1}{2}, \bar{x}, \frac{1}{2}-y;$   
 $y+\frac{1}{2}, z, x+\frac{1}{2}; \frac{1}{2}-y, \bar{z}, x+\frac{1}{2}; y+\frac{1}{2}, \bar{z}, \frac{1}{2}-x; \frac{1}{2}-y, z, \frac{1}{2}-x;$   
 $\frac{1}{2}-x, \bar{y}, \frac{1}{2}-z; \frac{1}{2}-x, y, z+\frac{1}{2}; x+\frac{1}{2}, \bar{y}, z+\frac{1}{2}; x+\frac{1}{2}, y, \frac{1}{2}-z;$   
 $\frac{1}{2}-z, \bar{x}, \frac{1}{2}-y; z+\frac{1}{2}, \bar{x}, y+\frac{1}{2}; z+\frac{1}{2}, x, \frac{1}{2}-y; \frac{1}{2}-z, x, y+\frac{1}{2};$   
 $\frac{1}{2}-y, \bar{z}, \frac{1}{2}-x; y+\frac{1}{2}, z, \frac{1}{2}-x; \frac{1}{2}-y, z, x+\frac{1}{2}; y+\frac{1}{2}, \bar{z}, x+\frac{1}{2};$   
 $x, y+\frac{1}{2}, z+\frac{1}{2}; x, \frac{1}{2}-y, \frac{1}{2}-z; \bar{x}, y+\frac{1}{2}, \frac{1}{2}-z; \bar{x}, \frac{1}{2}-y, z+\frac{1}{2};$   
 $z, x+\frac{1}{2}, y+\frac{1}{2}; \bar{z}, x+\frac{1}{2}, \frac{1}{2}-y; \bar{z}, \frac{1}{2}-x, y+\frac{1}{2}; z, \frac{1}{2}-x, \frac{1}{2}-y;$   
 $y, z+\frac{1}{2}, x+\frac{1}{2}; \bar{y}, \frac{1}{2}-z, x+\frac{1}{2}; y, \frac{1}{2}-z, \frac{1}{2}-x; \bar{y}, z+\frac{1}{2}, \frac{1}{2}-x;$   
 $\bar{x}, \frac{1}{2}-y, \frac{1}{2}-z; \bar{x}, y+\frac{1}{2}, z+\frac{1}{2}; x, \frac{1}{2}-y, z+\frac{1}{2}; x, y+\frac{1}{2}, \frac{1}{2}-z;$   
 $\bar{z}, \frac{1}{2}-x, \frac{1}{2}-y; z, \frac{1}{2}-x, y+\frac{1}{2}; z, x+\frac{1}{2}, \frac{1}{2}-y; \bar{z}, x+\frac{1}{2}, y+\frac{1}{2};$   
 $\bar{y}, \frac{1}{2}-z, \frac{1}{2}-x; y, z+\frac{1}{2}, \frac{1}{2}-x; \bar{y}, z+\frac{1}{2}, x+\frac{1}{2}; y, \frac{1}{2}-z, x+\frac{1}{2}.$

SPACE-GROUP  $T_2^4$ .

Eight equivalent positions:

(a) 8f. (b) 8g.

Sixteen equivalent positions:

(c) 16b. (d) 16c.

Thirty-two equivalent positions:

(e) 32b.

Forty-eight equivalent positions:

(f) 48c.

Ninety-six equivalent positions:

(g)  $xyz; x\bar{y}\bar{z}; \bar{x}y\bar{z}; \bar{x}\bar{y}z;$   
 $zxy; \bar{z}\bar{x}\bar{y}; \bar{z}\bar{x}y; z\bar{x}\bar{y};$   
 $yzx; \bar{y}\bar{z}\bar{x}; \bar{y}\bar{z}x; \bar{y}z\bar{x};$   
 $x+\frac{1}{2}, y+\frac{1}{2}, z; x+\frac{1}{2}, \frac{1}{2}-y, \bar{z}; \frac{1}{2}-x, y+\frac{1}{2}, \bar{z}; \frac{1}{2}-x, \frac{1}{2}-y, z;$   
 $z+\frac{1}{2}, x+\frac{1}{2}, y; \frac{1}{2}-z, x+\frac{1}{2}, \bar{y}; \frac{1}{2}-z, \frac{1}{2}-x, y; z+\frac{1}{2}, \frac{1}{2}-x, \bar{y};$   
 $y+\frac{1}{2}, z+\frac{1}{2}, x; \frac{1}{2}-y, \frac{1}{2}-z, x; y+\frac{1}{2}, \frac{1}{2}-z, \bar{x}; \frac{1}{2}-y, z+\frac{1}{2}, \bar{x};$   
 $x+\frac{1}{2}, y, z+\frac{1}{2}; x+\frac{1}{2}, \bar{y}, \frac{1}{2}-z; \frac{1}{2}-x, y, \frac{1}{2}-z; \frac{1}{2}-x, \bar{y}, z+\frac{1}{2};$   
 $z+\frac{1}{2}, x, y+\frac{1}{2}; \frac{1}{2}-z, x, \frac{1}{2}-y; \frac{1}{2}-z, \bar{x}, y+\frac{1}{2}; z+\frac{1}{2}, \bar{x}, \frac{1}{2}-y;$   
 $y+\frac{1}{2}, z, x+\frac{1}{2}; \frac{1}{2}-y, \bar{z}, x+\frac{1}{2}; y+\frac{1}{2}, \bar{z}, \frac{1}{2}-x; \frac{1}{2}-y, z, \frac{1}{2}-x;$   
 $x, y+\frac{1}{2}, z+\frac{1}{2}; x, \frac{1}{2}-y, \frac{1}{2}-z; \bar{x}, y+\frac{1}{2}, \frac{1}{2}-z; \bar{x}, \frac{1}{2}-y, z+\frac{1}{2};$   
 $z, x+\frac{1}{2}, y+\frac{1}{2}; \bar{z}, x+\frac{1}{2}, \frac{1}{2}-y; \bar{z}, \frac{1}{2}-x, y+\frac{1}{2}; z, \frac{1}{2}-x, \frac{1}{2}-y;$   
 $y, z+\frac{1}{2}, x+\frac{1}{2}; \bar{y}, \frac{1}{2}-z, x+\frac{1}{2}; y, \frac{1}{2}-z, \frac{1}{2}-x; \bar{y}, z+\frac{1}{2}, \frac{1}{2}-x;$   
 $\frac{1}{2}-x, \frac{1}{2}-y, \frac{1}{2}-z; \frac{1}{2}-x, y+\frac{1}{2}, z+\frac{1}{2}; x+\frac{1}{2}, \frac{1}{2}-y, z+\frac{1}{2};$   
 $\frac{1}{2}-z, \frac{1}{2}-x, \frac{1}{2}-y; z+\frac{1}{2}, \frac{1}{2}-x, y+\frac{1}{2}; z+\frac{1}{2}, x+\frac{1}{2}, \frac{1}{2}-y;$   
 $\frac{1}{2}-z, x+\frac{1}{2}, y+\frac{1}{2};$   
 $\frac{1}{2}-y, \frac{1}{2}-z, \frac{1}{2}-x; y+\frac{1}{2}, z+\frac{1}{2}, \frac{1}{2}-x; \frac{1}{2}-y, z+\frac{1}{2}, x+\frac{1}{2};$   
 $y+\frac{1}{2}, \frac{1}{2}-z, x+\frac{1}{2};$   
 $\frac{1}{2}-x, \frac{1}{2}-y, \frac{1}{2}-z; \frac{1}{2}-x, y+\frac{1}{2}, z+\frac{1}{2}; x+\frac{1}{2}, \frac{1}{2}-y, z+\frac{1}{2};$   
 $x+\frac{1}{2}, y+\frac{1}{2}, \frac{1}{2}-z;$

SPACE-GROUP  $T_2^4$  (continued).

$$\begin{array}{l}
\frac{1}{2}-z, \frac{1}{2}-x, \frac{1}{2}-y; \quad z+\frac{1}{2}, \frac{1}{2}-x, y+\frac{1}{2}; \quad z+\frac{1}{2}, x+\frac{1}{2}, \frac{1}{2}-y; \\
\frac{1}{2}-z, x+\frac{1}{2}, y+\frac{1}{2}; \\
\frac{1}{2}-y, \frac{1}{2}-z, \frac{1}{2}-x; \quad y+\frac{1}{2}, z+\frac{1}{2}, \frac{1}{2}-x; \quad \frac{1}{2}-y, z+\frac{1}{2}, x+\frac{1}{2}; \\
y+\frac{1}{2}, \frac{1}{2}-z, x+\frac{1}{2}; \\
\frac{1}{2}-x, \frac{1}{2}-y, \frac{1}{2}-z; \quad \frac{1}{2}-x, y+\frac{1}{2}, z+\frac{1}{2}; \quad x+\frac{1}{2}, \frac{1}{2}-y, z+\frac{1}{2}; \\
x+\frac{1}{2}, y+\frac{1}{2}, \frac{1}{2}-z; \\
\frac{1}{2}-z, \frac{1}{2}-x, \frac{1}{2}-y; \quad z+\frac{1}{2}, \frac{1}{2}-x, y+\frac{1}{2}; \quad z+\frac{1}{2}, x+\frac{1}{2}, \frac{1}{2}-y; \\
\frac{1}{2}-z, x+\frac{1}{2}, y+\frac{1}{2}; \\
\frac{1}{2}-y, \frac{1}{2}-z, \frac{1}{2}-x; \quad y+\frac{1}{2}, z+\frac{1}{2}, \frac{1}{2}-x; \quad \frac{1}{2}-y, z+\frac{1}{2}, x+\frac{1}{2}; \\
y+\frac{1}{2}, \frac{1}{2}-z, x+\frac{1}{2}; \\
\frac{1}{2}-x, \frac{1}{2}-y, \frac{1}{2}-z; \quad \frac{1}{2}-x, y+\frac{1}{2}, z+\frac{1}{2}; \quad x+\frac{1}{2}, \frac{1}{2}-y, z+\frac{1}{2}; \\
x+\frac{1}{2}, y+\frac{1}{2}, \frac{1}{2}-z; \\
\frac{1}{2}-z, \frac{1}{2}-x, \frac{1}{2}-y; \quad z+\frac{1}{2}, \frac{1}{2}-x, y+\frac{1}{2}; \quad z+\frac{1}{2}, x+\frac{1}{2}, \frac{1}{2}-y; \\
\frac{1}{2}-z, x+\frac{1}{2}, y+\frac{1}{2}; \\
\frac{1}{2}-y, \frac{1}{2}-z, \frac{1}{2}-x; \quad y+\frac{1}{2}, z+\frac{1}{2}, \frac{1}{2}-x; \quad \frac{1}{2}-y, z+\frac{1}{2}, x+\frac{1}{2}; \\
y+\frac{1}{2}, \frac{1}{2}-z, x+\frac{1}{2}.
\end{array}$$

SPACE-GROUP  $T_2^5$ .

Two equivalent positions:

(a) 2a.

Six equivalent positions:

(b) 6e.

Eight equivalent positions:

(c) 8e.

Twelve equivalent positions:

(d) 12a. (e) 12b.

Sixteen equivalent positions:

(f) 16d.

Twenty-four equivalent positions:

(g) 24d.

Forty-eight equivalent positions:

$$\begin{array}{l}
\text{(h) } xyz; \quad x\bar{y}\bar{z}; \quad \bar{x}y\bar{z}; \quad \bar{x}\bar{y}z; \\
zxy; \quad \bar{z}x\bar{y}; \quad \bar{z}\bar{x}y; \quad z\bar{x}\bar{y}; \\
yzx; \quad \bar{y}\bar{z}x; \quad y\bar{z}\bar{x}; \quad \bar{y}z\bar{x}; \\
\bar{x}y\bar{z}; \quad \bar{x}yz; \quad x\bar{y}z; \quad xy\bar{z}; \\
\bar{z}\bar{x}\bar{y}; \quad z\bar{x}y; \quad z\bar{x}\bar{y}; \quad \bar{z}xy; \\
\bar{y}\bar{z}\bar{x}; \quad yz\bar{x}; \quad \bar{y}zx; \quad y\bar{z}x; \\
x+\frac{1}{2}, y+\frac{1}{2}, z+\frac{1}{2}; \quad x+\frac{1}{2}, \frac{1}{2}-y, \frac{1}{2}-z; \quad \frac{1}{2}-x, y+\frac{1}{2}, \frac{1}{2}-z; \\
\frac{1}{2}-x, \frac{1}{2}-y, z+\frac{1}{2}; \\
z+\frac{1}{2}, x+\frac{1}{2}, y+\frac{1}{2}; \quad \frac{1}{2}-z, x+\frac{1}{2}, \frac{1}{2}-y; \quad \frac{1}{2}-z, \frac{1}{2}-x, y+\frac{1}{2}; \\
z+\frac{1}{2}, \frac{1}{2}-x, \frac{1}{2}-y;
\end{array}$$

SPACE-GROUP  $T_2^5$  (continued).

$$\begin{aligned}
 &y+\frac{1}{2}, z+\frac{1}{2}, x+\frac{1}{2}; \quad \frac{1}{2}-y, \frac{1}{2}-z, x+\frac{1}{2}; \quad y+\frac{1}{2}, \frac{1}{2}-z, \frac{1}{2}-x; \\
 & \qquad \qquad \qquad \qquad \qquad \qquad \qquad \qquad \qquad \qquad \qquad \qquad \qquad \frac{1}{2}-y, z+\frac{1}{2}, \frac{1}{2}-x; \\
 &\frac{1}{2}-x, \frac{1}{2}-y, \frac{1}{2}-z; \quad \frac{1}{2}-x, y+\frac{1}{2}, z+\frac{1}{2}; \quad x+\frac{1}{2}, \frac{1}{2}-y, z+\frac{1}{2}; \\
 & \qquad \qquad \qquad \qquad \qquad \qquad \qquad \qquad \qquad \qquad \qquad \qquad \qquad x+\frac{1}{2}, y+\frac{1}{2}, \frac{1}{2}-z; \\
 &\frac{1}{2}-z, \frac{1}{2}-x, \frac{1}{2}-y; \quad z+\frac{1}{2}, \frac{1}{2}-x, y+\frac{1}{2}; \quad z+\frac{1}{2}, x+\frac{1}{2}, \frac{1}{2}-y; \\
 & \qquad \qquad \qquad \qquad \qquad \qquad \qquad \qquad \qquad \qquad \qquad \qquad \qquad \frac{1}{2}-z, x+\frac{1}{2}, y+\frac{1}{2}; \\
 &\frac{1}{2}-y, \frac{1}{2}-z, \frac{1}{2}-x; \quad y+\frac{1}{2}, z+\frac{1}{2}, \frac{1}{2}-x; \quad \frac{1}{2}-y, z+\frac{1}{2}, x+\frac{1}{2}; \\
 & \qquad \qquad \qquad \qquad \qquad \qquad \qquad \qquad \qquad \qquad \qquad \qquad \qquad y+\frac{1}{2}, \frac{1}{2}-z, x+\frac{1}{2}.
 \end{aligned}$$

SPACE-GROUP  $T_2^6$ .

Four equivalent positions:

(a) 4b.                      (b) 4c.

Eight equivalent positions:

(c) 8h.

Twenty-four equivalent positions:

(d)  $xyz$ ;  $x+\frac{1}{2}, \frac{1}{2}-y, \bar{z}$ ;  $\bar{x}, y+\frac{1}{2}, \frac{1}{2}-z$ ;  $\frac{1}{2}-x, \bar{y}, z+\frac{1}{2}$ ;  
 $zxy$ ;  $\bar{z}, x+\frac{1}{2}, \frac{1}{2}-y$ ;  $\frac{1}{2}-z, \bar{x}, y+\frac{1}{2}$ ;  $z+\frac{1}{2}, \frac{1}{2}-x, \bar{y}$ ;  
 $yzx$ ;  $\frac{1}{2}-y, \bar{z}, x+\frac{1}{2}$ ;  $y+\frac{1}{2}, \frac{1}{2}-z, \bar{x}$ ;  $\bar{y}, z+\frac{1}{2}, \frac{1}{2}-x$ ;  
 $\bar{x}\bar{y}\bar{z}$ ;  $\frac{1}{2}-x, y+\frac{1}{2}, z$ ;  $x, \frac{1}{2}-y, z+\frac{1}{2}$ ;  $x+\frac{1}{2}, y, \frac{1}{2}-z$ ;  
 $\bar{z}\bar{x}\bar{y}$ ;  $z, \frac{1}{2}-x, y+\frac{1}{2}$ ;  $z+\frac{1}{2}, x, \frac{1}{2}-y$ ;  $\frac{1}{2}-z, x+\frac{1}{2}, y$ ;  
 $\bar{y}\bar{z}\bar{x}$ ;  $y+\frac{1}{2}, z, \frac{1}{2}-x$ ;  $\frac{1}{2}-y, z+\frac{1}{2}, x$ ;  $y, \frac{1}{2}-z, x+\frac{1}{2}$

SPACE-GROUP  $T_2^7$ .

Eight equivalent positions:

(a) 8i.                      (b) 8e.

Sixteen equivalent positions:

(c) 16e.

Twenty-four equivalent positions:

(d) 24e.

Forty-eight equivalent positions:

(e)  $xyz$ ;  $x, \bar{y}, \frac{1}{2}-z$ ;  $\frac{1}{2}-x, y, \bar{z}$ ;  $\bar{x}, \frac{1}{2}-y, z$ ;  
 $zxy$ ;  $\frac{1}{2}-z, x, \bar{y}$ ;  $\bar{z}, \frac{1}{2}-x, y$ ;  $z, \bar{x}, \frac{1}{2}-y$ ;  
 $yzx$ ;  $\bar{y}, \frac{1}{2}-z, x$ ;  $y, \bar{z}, \frac{1}{2}-x$ ;  $\frac{1}{2}-y, z, \bar{x}$ ;  
 $\bar{x}\bar{y}\bar{z}$ ;  $\bar{x}, y, z+\frac{1}{2}$ ;  $x+\frac{1}{2}, \bar{y}, z$ ;  $x, y+\frac{1}{2}, \bar{z}$ ;  
 $\bar{z}\bar{x}\bar{y}$ ;  $z+\frac{1}{2}, \bar{x}, y$ ;  $z, x+\frac{1}{2}, \bar{y}$ ;  $\bar{z}, x, y+\frac{1}{2}$ ;  
 $\bar{y}\bar{z}\bar{x}$ ;  $y, z+\frac{1}{2}, \bar{x}$ ;  $\bar{y}, z, x+\frac{1}{2}$ ;  $y+\frac{1}{2}, \bar{z}, x$ ;  
 $x+\frac{1}{2}, y+\frac{1}{2}, z+\frac{1}{2}$ ;  $x+\frac{1}{2}, \frac{1}{2}-y, \bar{z}$ ;  $\bar{x}, y+\frac{1}{2}, \frac{1}{2}-z$ ;  
 $\frac{1}{2}-x, \bar{y}, z+\frac{1}{2}$ ;  
 $z+\frac{1}{2}, x+\frac{1}{2}, y+\frac{1}{2}$ ;  $\bar{z}, x+\frac{1}{2}, \frac{1}{2}-y$ ;  $\frac{1}{2}-z, \bar{x}, y+\frac{1}{2}$ ;  
 $z+\frac{1}{2}, \frac{1}{2}-x, \bar{y}$ ;  
 $y+\frac{1}{2}, z+\frac{1}{2}, x+\frac{1}{2}$ ;  $\frac{1}{2}-y, \bar{z}, x+\frac{1}{2}$ ;  $y+\frac{1}{2}, \frac{1}{2}-z, \bar{x}$ ;  
 $\bar{y}, z+\frac{1}{2}, \frac{1}{2}-x$ ;



SPACE-GROUP  $T_d^2$  (continued).

*Ninety-six* equivalent positions:

- (i)  $xyz$ ;  $x\bar{y}\bar{z}$ ;  $\bar{x}y\bar{z}$ ;  $\bar{x}\bar{y}z$ ;  
 $zxy$ ;  $\bar{z}x\bar{y}$ ;  $\bar{z}\bar{x}y$ ;  $z\bar{x}\bar{y}$ ;  
 $yzx$ ;  $\bar{y}\bar{z}x$ ;  $y\bar{z}\bar{x}$ ;  $\bar{y}z\bar{x}$ ;  
 $yxz$ ;  $\bar{y}x\bar{z}$ ;  $y\bar{x}\bar{z}$ ;  $\bar{y}\bar{x}z$ ;  
 $xzy$ ;  $x\bar{z}\bar{y}$ ;  $\bar{x}\bar{z}y$ ;  $\bar{x}z\bar{y}$ ;  
 $zyx$ ;  $\bar{z}\bar{y}x$ ;  $\bar{z}y\bar{x}$ ;  $z\bar{y}\bar{x}$ ;  
 $x+\frac{1}{2}, y+\frac{1}{2}, z$ ;  $x+\frac{1}{2}, \frac{1}{2}-y, \bar{z}$ ;  $\frac{1}{2}-x, y+\frac{1}{2}, \bar{z}$ ;  $\frac{1}{2}-x, \frac{1}{2}-y, z$ ;  
 $z+\frac{1}{2}, x+\frac{1}{2}, y$ ;  $\frac{1}{2}-z, x+\frac{1}{2}, \bar{y}$ ;  $\frac{1}{2}-z, \frac{1}{2}-x, y$ ;  $z+\frac{1}{2}, \frac{1}{2}-x, \bar{y}$ ;  
 $y+\frac{1}{2}, z+\frac{1}{2}, x$ ;  $\frac{1}{2}-y, \frac{1}{2}-z, x$ ;  $y+\frac{1}{2}, \frac{1}{2}-z, \bar{x}$ ;  $\frac{1}{2}-y, z+\frac{1}{2}, \bar{x}$ ;  
 $y+\frac{1}{2}, x+\frac{1}{2}, z$ ;  $\frac{1}{2}-y, x+\frac{1}{2}, \bar{z}$ ;  $y+\frac{1}{2}, \frac{1}{2}-x, \bar{z}$ ;  $\frac{1}{2}-y, \frac{1}{2}-x, z$ ;  
 $x+\frac{1}{2}, z+\frac{1}{2}, y$ ;  $x+\frac{1}{2}, \frac{1}{2}-z, \bar{y}$ ;  $\frac{1}{2}-x, \frac{1}{2}-z, y$ ;  $\frac{1}{2}-x, z+\frac{1}{2}, \bar{y}$ ;  
 $z+\frac{1}{2}, y+\frac{1}{2}, x$ ;  $\frac{1}{2}-z, \frac{1}{2}-y, x$ ;  $\frac{1}{2}-z, y+\frac{1}{2}, \bar{x}$ ;  $z+\frac{1}{2}, \frac{1}{2}-y, \bar{x}$ ;  
 $x+\frac{1}{2}, y, z+\frac{1}{2}$ ;  $x+\frac{1}{2}, \bar{y}, \frac{1}{2}-z$ ;  $\frac{1}{2}-x, y, \frac{1}{2}-z$ ;  $\frac{1}{2}-x, \bar{y}, z+\frac{1}{2}$ ;  
 $z+\frac{1}{2}, x, y+\frac{1}{2}$ ;  $\frac{1}{2}-z, x, \frac{1}{2}-y$ ;  $\frac{1}{2}-z, \bar{x}, y+\frac{1}{2}$ ;  $z+\frac{1}{2}, \bar{x}, \frac{1}{2}-y$ ;  
 $y+\frac{1}{2}, z, x+\frac{1}{2}$ ;  $\frac{1}{2}-y, \bar{z}, x+\frac{1}{2}$ ;  $y+\frac{1}{2}, \bar{z}, \frac{1}{2}-x$ ;  $\frac{1}{2}-y, z, \frac{1}{2}-x$ ;  
 $y+\frac{1}{2}, x, z+\frac{1}{2}$ ;  $\frac{1}{2}-y, x, \frac{1}{2}-z$ ;  $y+\frac{1}{2}, \bar{x}, \frac{1}{2}-z$ ;  $\frac{1}{2}-y, \bar{x}, z+\frac{1}{2}$ ;  
 $x+\frac{1}{2}, z, y+\frac{1}{2}$ ;  $x+\frac{1}{2}, \bar{z}, \frac{1}{2}-y$ ;  $\frac{1}{2}-x, \bar{z}, y+\frac{1}{2}$ ;  $\frac{1}{2}-x, z, \frac{1}{2}-y$ ;  
 $z+\frac{1}{2}, y, x+\frac{1}{2}$ ;  $\frac{1}{2}-z, \bar{y}, x+\frac{1}{2}$ ;  $\frac{1}{2}-z, y, \frac{1}{2}-x$ ;  $z+\frac{1}{2}, \bar{y}, \frac{1}{2}-x$ ;  
 $x, y+\frac{1}{2}, z+\frac{1}{2}$ ;  $x, \frac{1}{2}-y, \frac{1}{2}-z$ ;  $\bar{x}, y+\frac{1}{2}, \frac{1}{2}-z$ ;  $\bar{x}, \frac{1}{2}-y, z+\frac{1}{2}$ ;  
 $z, x+\frac{1}{2}, y+\frac{1}{2}$ ;  $\bar{z}, x+\frac{1}{2}, \frac{1}{2}-y$ ;  $\bar{z}, \frac{1}{2}-x, y+\frac{1}{2}$ ;  $z, \frac{1}{2}-x, \frac{1}{2}-y$ ;  
 $y, z+\frac{1}{2}, x+\frac{1}{2}$ ;  $\bar{y}, \frac{1}{2}-z, x+\frac{1}{2}$ ;  $y, \frac{1}{2}-z, \frac{1}{2}-x$ ;  $\bar{y}, z+\frac{1}{2}, \frac{1}{2}-x$ ;  
 $y, x+\frac{1}{2}, z+\frac{1}{2}$ ;  $\bar{y}, x+\frac{1}{2}, \frac{1}{2}-z$ ;  $y, \frac{1}{2}-x, \frac{1}{2}-z$ ;  $\bar{y}, \frac{1}{2}-x, z+\frac{1}{2}$ ;  
 $x, z+\frac{1}{2}, y+\frac{1}{2}$ ;  $x, \frac{1}{2}-z, \frac{1}{2}-y$ ;  $\bar{x}, \frac{1}{2}-z, y+\frac{1}{2}$ ;  $\bar{x}, z+\frac{1}{2}, \frac{1}{2}-y$ ;  
 $z, y+\frac{1}{2}, x+\frac{1}{2}$ ;  $\bar{z}, \frac{1}{2}-y, x+\frac{1}{2}$ ;  $\bar{z}, y+\frac{1}{2}, \frac{1}{2}-x$ ;  $z, \frac{1}{2}-y, \frac{1}{2}-x$ .

SPACE-GROUP  $T_d^3$ .

*Two* equivalent positions:

- (a) 2a.

*Six* equivalent positions:

- (b) 6c.

*Eight* equivalent positions:

- (c) 8a.

*Twelve* equivalent positions:

- (d) 12h. (e) 12a.

*Twenty-four* equivalent positions:

- (f) 24f. (g) 24g.

*Forty-eight* equivalent positions:

- (h)  $xyz$ ;  $x\bar{y}\bar{z}$ ;  $\bar{x}y\bar{z}$ ;  $\bar{x}\bar{y}z$ ;  
 $zxy$ ;  $\bar{z}x\bar{y}$ ;  $\bar{z}\bar{x}y$ ;  $z\bar{x}\bar{y}$ ;  
 $yxz$ ;  $\bar{y}\bar{z}x$ ;  $y\bar{z}\bar{x}$ ;  $\bar{y}z\bar{x}$ ;  
 $yxz$ ;  $\bar{y}x\bar{z}$ ;  $y\bar{x}\bar{z}$ ;  $\bar{y}\bar{x}z$ ;  
 $xzy$ ;  $x\bar{z}\bar{y}$ ;  $\bar{x}\bar{z}y$ ;  $\bar{x}z\bar{y}$ ;  
 $zyx$ ;  $\bar{z}\bar{y}x$ ;  $\bar{z}y\bar{x}$ ;  $z\bar{y}\bar{x}$ ;



SPACE-GROUP  $T_d^3$  (continued).

$$\begin{array}{ll} x+\frac{1}{2}, y+\frac{1}{2}, z+\frac{1}{2}; & x+\frac{1}{2}, \frac{1}{2}-y, \frac{1}{2}-z; \quad \frac{1}{2}-x, y+\frac{1}{2}, \frac{1}{2}-z; \\ & \frac{1}{2}-x, \frac{1}{2}-y, z+\frac{1}{2}; \\ z+\frac{1}{2}, x+\frac{1}{2}, y+\frac{1}{2}; & \frac{1}{2}-z, x+\frac{1}{2}, \frac{1}{2}-y; \quad \frac{1}{2}-z, \frac{1}{2}-x, y+\frac{1}{2}; \\ & z+\frac{1}{2}, \frac{1}{2}-x, \frac{1}{2}-y; \\ y+\frac{1}{2}, z+\frac{1}{2}, x+\frac{1}{2}; & \frac{1}{2}-y, \frac{1}{2}-z, x+\frac{1}{2}; \quad y+\frac{1}{2}, \frac{1}{2}-z, \frac{1}{2}-x; \\ & \frac{1}{2}-y, z+\frac{1}{2}, \frac{1}{2}-x; \\ y+\frac{1}{2}, x+\frac{1}{2}, z+\frac{1}{2}; & \frac{1}{2}-y, x+\frac{1}{2}, \frac{1}{2}-z; \quad y+\frac{1}{2}, \frac{1}{2}-x, \frac{1}{2}-z; \\ & \frac{1}{2}-y, \frac{1}{2}-x, z+\frac{1}{2}; \\ x+\frac{1}{2}, z+\frac{1}{2}, y+\frac{1}{2}; & x+\frac{1}{2}, \frac{1}{2}-z, \frac{1}{2}-y; \quad \frac{1}{2}-x, \frac{1}{2}-z, y+\frac{1}{2}; \\ & \frac{1}{2}-x, z+\frac{1}{2}, \frac{1}{2}-y; \\ z+\frac{1}{2}, y+\frac{1}{2}, x+\frac{1}{2}; & \frac{1}{2}-z, \frac{1}{2}-y, x+\frac{1}{2}; \quad \frac{1}{2}-z, y+\frac{1}{2}, \frac{1}{2}-x; \\ & z+\frac{1}{2}, \frac{1}{2}-y, \frac{1}{2}-x; \end{array}$$

SPACE-GROUP  $T_d^4$ .*Two* equivalent positions:

(a) 2a.

*Six* equivalent positions:

(b) 6e. (d) 6g.

(c) 6f.

*Eight* equivalent positions:

(e) 8a.

*Twelve* equivalent positions:

(f) 12a. (h) 12j.

(g) 12i.

*Twenty-four* equivalent positions:

$$\begin{array}{ll} (i) \quad xyz; & x\bar{y}\bar{z}; & \bar{x}y\bar{z}; & \bar{x}\bar{y}z; \\ & x\bar{y}z; & \bar{x}y\bar{z}; & \bar{x}\bar{y}z; \\ & y\bar{z}x; & \bar{y}\bar{z}x; & y\bar{z}\bar{x}; \\ & y+\frac{1}{2}, x+\frac{1}{2}, z+\frac{1}{2}; & \frac{1}{2}-y, x+\frac{1}{2}, \frac{1}{2}-z; & y+\frac{1}{2}, \frac{1}{2}-x, \frac{1}{2}-z; \\ & & & \frac{1}{2}-y, \frac{1}{2}-x, z+\frac{1}{2}; \\ & x+\frac{1}{2}, z+\frac{1}{2}, y+\frac{1}{2}; & x+\frac{1}{2}, \frac{1}{2}-z, \frac{1}{2}-y; & \frac{1}{2}-x, \frac{1}{2}-z, y+\frac{1}{2}; \\ & & & \frac{1}{2}-x, z+\frac{1}{2}, \frac{1}{2}-y; \\ & z+\frac{1}{2}, y+\frac{1}{2}, x+\frac{1}{2}; & \frac{1}{2}-z, \frac{1}{2}-y, x+\frac{1}{2}; & \frac{1}{2}-z, y+\frac{1}{2}, \frac{1}{2}-x; \\ & & & z+\frac{1}{2}, \frac{1}{2}-y, \frac{1}{2}-x. \end{array}$$

SPACE-GROUP  $T_d^5$ .*Eight* equivalent positions:

(a) 8i. (b) 8e.

*Twenty-four* equivalent positions:

(c) 24c. (d) 24h.

*Thirty-two* equivalent positions:

(e) 32c.

SPACE-GROUP  $T_4^5$  (continued).

Forty-eight equivalent positions:

(f) 48c. (g) 48a.

Ninety-six equivalent positions:

(h)  $xyz$ ;  $x\bar{y}\bar{z}$ ;  $\bar{x}y\bar{z}$ ;  $\bar{x}\bar{y}z$ ;  
 $zxy$ ;  $\bar{z}x\bar{y}$ ;  $\bar{z}\bar{x}y$ ;  $z\bar{x}\bar{y}$ ;  
 $yzx$ ;  $\bar{y}\bar{z}x$ ;  $y\bar{z}\bar{x}$ ;  $\bar{y}z\bar{x}$ ;  
 $y+\frac{1}{2}, x+\frac{1}{2}, z+\frac{1}{2}; \frac{1}{2}-y, x+\frac{1}{2}, \frac{1}{2}-z; y+\frac{1}{2}, \frac{1}{2}-x, \frac{1}{2}-z;$   
 $\frac{1}{2}-y, \frac{1}{2}-x, z+\frac{1}{2};$   
 $x+\frac{1}{2}, z+\frac{1}{2}, y+\frac{1}{2}; x+\frac{1}{2}, \frac{1}{2}-z, \frac{1}{2}-y; \frac{1}{2}-x, \frac{1}{2}-z, y+\frac{1}{2};$   
 $\frac{1}{2}-x, z+\frac{1}{2}, \frac{1}{2}-y;$   
 $z+\frac{1}{2}, y+\frac{1}{2}, x+\frac{1}{2}; \frac{1}{2}-z, \frac{1}{2}-y, x+\frac{1}{2}; \frac{1}{2}-z, y+\frac{1}{2}, \frac{1}{2}-x;$   
 $z+\frac{1}{2}, \frac{1}{2}-y, \frac{1}{2}-x;$   
 $x+\frac{1}{2}, y+\frac{1}{2}, z; x+\frac{1}{2}, \frac{1}{2}-y, \bar{z}; \frac{1}{2}-x, y+\frac{1}{2}, \bar{z}; \frac{1}{2}-x, \frac{1}{2}-y, z;$   
 $z+\frac{1}{2}, x+\frac{1}{2}, y; \frac{1}{2}-z, x+\frac{1}{2}, \bar{y}; \frac{1}{2}-z, \frac{1}{2}-x, y; z+\frac{1}{2}, \frac{1}{2}-x, \bar{y};$   
 $y+\frac{1}{2}, z+\frac{1}{2}, x; \frac{1}{2}-y, \frac{1}{2}-z, x; y+\frac{1}{2}, \frac{1}{2}-z, \bar{x}; \frac{1}{2}-y, z+\frac{1}{2}, \bar{x};$   
 $y, x, z+\frac{1}{2}; \bar{y}, x, \frac{1}{2}-z; y, \bar{x}, \frac{1}{2}-z; \bar{y}, \bar{x}, z+\frac{1}{2};$   
 $x, z, y+\frac{1}{2}; x, \bar{z}, \frac{1}{2}-y; \bar{x}, \bar{z}, y+\frac{1}{2}; \bar{x}, z, \frac{1}{2}-y;$   
 $z, y, x+\frac{1}{2}; \bar{z}, \bar{y}, x+\frac{1}{2}; \bar{z}, y, \frac{1}{2}-x; z, \bar{y}, \frac{1}{2}-x;$   
 $x+\frac{1}{2}, y, z+\frac{1}{2}; x+\frac{1}{2}, \bar{y}, \frac{1}{2}-z; \frac{1}{2}-x, y, \frac{1}{2}-z; \frac{1}{2}-x, \bar{y}, z+\frac{1}{2};$   
 $z+\frac{1}{2}, x, y+\frac{1}{2}; \frac{1}{2}-z, x, \frac{1}{2}-y; \frac{1}{2}-z, \bar{x}, y+\frac{1}{2}; z+\frac{1}{2}, \bar{x}, \frac{1}{2}-y;$   
 $y+\frac{1}{2}, z, x+\frac{1}{2}; \frac{1}{2}-y, \bar{z}, x+\frac{1}{2}; y+\frac{1}{2}, \bar{z}, \frac{1}{2}-x; \frac{1}{2}-y, z, \frac{1}{2}-x;$   
 $y, x+\frac{1}{2}, z; \bar{y}, x+\frac{1}{2}, \bar{z}; y, \frac{1}{2}-x, \bar{z}; \bar{y}, \frac{1}{2}-x, z;$   
 $x, z+\frac{1}{2}, y; x, \frac{1}{2}-z, \bar{y}; \bar{x}, \frac{1}{2}-z, y; \bar{x}, z+\frac{1}{2}, \bar{y};$   
 $z, y+\frac{1}{2}, x; \bar{z}, \frac{1}{2}-y, x; \bar{z}, y+\frac{1}{2}, \bar{x}; z, \frac{1}{2}-y, \bar{x};$   
 $x, y+\frac{1}{2}, z+\frac{1}{2}; x, \frac{1}{2}-y, \frac{1}{2}-z; \bar{x}, y+\frac{1}{2}, \frac{1}{2}-z; \bar{x}, \frac{1}{2}-y, z+\frac{1}{2};$   
 $z, x+\frac{1}{2}, y+\frac{1}{2}; \bar{z}, x+\frac{1}{2}, \frac{1}{2}-y; \bar{z}, \frac{1}{2}-x, y+\frac{1}{2}; z, \frac{1}{2}-x, \frac{1}{2}-y;$   
 $y, z+\frac{1}{2}, x+\frac{1}{2}; \bar{y}, \frac{1}{2}-z, x+\frac{1}{2}; y, \frac{1}{2}-z, \frac{1}{2}-x; \bar{y}, z+\frac{1}{2}, \frac{1}{2}-x;$   
 $y+\frac{1}{2}, x, z; \frac{1}{2}-y, x, \bar{z}; y+\frac{1}{2}, \bar{x}, \bar{z}; \frac{1}{2}-y, \bar{x}, z;$   
 $x+\frac{1}{2}, z, y; x+\frac{1}{2}, \bar{z}, \bar{y}; \frac{1}{2}-x, \bar{z}, y; \frac{1}{2}-x, z, \bar{y};$   
 $z+\frac{1}{2}, y, x; \frac{1}{2}-z, \bar{y}, x; \frac{1}{2}-z, y, \bar{x}; z+\frac{1}{2}, \bar{y}, \bar{x}.$

SPACE-GROUP  $T_4^6$ .

Twelve equivalent positions:

(a) 12k. (b) 12l.

Sixteen equivalent positions:

(c) 16f.

Twenty-four equivalent positions:

(d) 24i.

Forty-eight equivalent positions:

(e)  $xyz$ ;  $x, \bar{y}, \frac{1}{2}-z; \frac{1}{2}-x, y, \bar{z}; \bar{x}, \frac{1}{2}-y, z;$   
 $zxy$ ;  $\frac{1}{2}-z, x, \bar{y}; \bar{z}, \frac{1}{2}-x, y; z, \bar{x}, \frac{1}{2}-y;$   
 $yzx$ ;  $\bar{y}, \frac{1}{2}-z, x; y, \bar{z}, \frac{1}{2}-x; \frac{1}{2}-y, z, \bar{x};$

SPACE-GROUP  $T_2^6$  (continued).

$$\begin{array}{l}
y+\frac{1}{2}, x+\frac{1}{2}, z+\frac{1}{2}; \quad \frac{1}{2}-y, x+\frac{1}{2}, \frac{1}{2}-z; \quad y+\frac{1}{2}, \frac{1}{2}-x, \frac{1}{2}-z; \\
\frac{1}{2}-y, \frac{1}{2}-x, z+\frac{1}{2}; \\
x+\frac{1}{2}, z+\frac{1}{2}, y+\frac{1}{2}; \quad x+\frac{1}{2}, \frac{1}{2}-z, \frac{1}{2}-y; \quad \frac{1}{2}-x, \frac{1}{2}-z, y+\frac{1}{2}; \\
\frac{1}{2}-x, z+\frac{1}{2}, \frac{1}{2}-y; \\
z+\frac{1}{2}, y+\frac{1}{2}, x+\frac{1}{2}; \quad \frac{1}{2}-z, \frac{1}{2}-y, x+\frac{1}{2}; \quad \frac{1}{2}-z, y+\frac{1}{2}, \frac{1}{2}-x; \\
z+\frac{1}{2}, \frac{1}{2}-y, \frac{1}{2}-x; \\
x+\frac{1}{2}, y+\frac{1}{2}, z+\frac{1}{2}; \quad x+\frac{1}{2}, \frac{1}{2}-y, \bar{z}; \quad \bar{x}, y+\frac{1}{2}, \frac{1}{2}-z; \\
\frac{1}{2}-x, \bar{y}, z+\frac{1}{2}; \\
z+\frac{1}{2}, x+\frac{1}{2}, y+\frac{1}{2}; \quad \bar{z}, x+\frac{1}{2}, \frac{1}{2}-y; \quad \frac{1}{2}-z, \bar{x}, y+\frac{1}{2}; \\
z+\frac{1}{2}, \frac{1}{2}-x, \bar{y}; \\
y+\frac{1}{2}, z+\frac{1}{2}, x+\frac{1}{2}; \quad \frac{1}{2}-y, \bar{z}, x+\frac{1}{2}; \quad y+\frac{1}{2}, \frac{1}{2}-z, \bar{x}; \\
\bar{y}, z+\frac{1}{2}, \frac{1}{2}-x; \\
y+\frac{1}{2}, x+\frac{1}{2}, z+\frac{1}{2}; \quad \frac{1}{2}-y, x+\frac{1}{2}, \frac{1}{2}-z; \quad y+\frac{1}{2}, \frac{1}{2}-x, \frac{1}{2}-z; \\
\frac{1}{2}-y, \frac{1}{2}-x, z+\frac{1}{2}; \\
x+\frac{1}{2}, z+\frac{1}{2}, y+\frac{1}{2}; \quad x+\frac{1}{2}, \frac{1}{2}-z, \frac{1}{2}-y; \quad \frac{1}{2}-x, \frac{1}{2}-z, y+\frac{1}{2}; \\
\frac{1}{2}-x, z+\frac{1}{2}, \frac{1}{2}-y; \\
z+\frac{1}{2}, y+\frac{1}{2}, x+\frac{1}{2}; \quad \frac{1}{2}-z, \frac{1}{2}-y, x+\frac{1}{2}; \quad \frac{1}{2}-z, y+\frac{1}{2}, \frac{1}{2}-x; \\
z+\frac{1}{2}, \frac{1}{2}-y, \frac{1}{2}-x.
\end{array}$$

## D. ENANTIOMORPHIC HEMIHEDRY.

SPACE-GROUP  $O^1$ .

One equivalent position:

(a) 1a.            (b) 1b.

Three equivalent positions:

(c) 3a.            (d) 3b.

Six equivalent positions:

(e) 6a.            (g) 6c.

(f) 6b.            (h) 6d.

Eight equivalent positions:

(i) 8c.

Twelve equivalent positions:

(j) 12m.            (k) 12n.

Twenty-four equivalent positions:

(l)  $xyz; \quad x\bar{y}\bar{z}; \quad \bar{x}y\bar{z}; \quad \bar{x}\bar{y}z;$   
 $zxy; \quad \bar{z}\bar{x}\bar{y}; \quad \bar{z}\bar{x}y; \quad z\bar{x}\bar{y};$   
 $yxz; \quad \bar{y}\bar{z}x; \quad y\bar{z}\bar{x}; \quad \bar{y}z\bar{x};$   
 $\bar{y}\bar{z}\bar{x}; \quad y\bar{x}z; \quad \bar{y}xz; \quad yx\bar{z};$   
 $\bar{z}\bar{x}\bar{y}; \quad \bar{z}\bar{x}y; \quad xz\bar{y}; \quad x\bar{z}y;$   
 $\bar{z}\bar{y}\bar{x}; \quad zy\bar{x}; \quad z\bar{y}x; \quad \bar{z}yx.$

SPACE-GROUP  $O^2$ .

*Two* equivalent positions:

(a) 2a.

*Four* equivalent positions:

(b) 4d.            (c) 4e.

*Six* equivalent positions:

(d) 6e.            (f) 6g.  
(e) 6f.

*Eight* equivalent positions:

(g) 8d.

*Twelve* equivalent positions:

(h) 12a.            (k) 12o.  
(i) 12i.            (l) 12p.  
(j) 12j.

*Twenty-four* equivalent positions:

(m)  $xyz$ ;     $x\bar{y}\bar{z}$ ;     $\bar{x}y\bar{z}$ ;     $\bar{x}\bar{y}z$ ;  
 $zxy$ ;     $\bar{z}x\bar{y}$ ;     $\bar{z}\bar{x}y$ ;     $z\bar{x}\bar{y}$ ;  
 $yzx$ ;     $\bar{y}\bar{z}x$ ;     $y\bar{z}\bar{x}$ ;     $\bar{y}z\bar{x}$ ;  
 $\frac{1}{2}-y, \frac{1}{2}-x, \frac{1}{2}-z$ ;  $y+\frac{1}{2}, \frac{1}{2}-x, z+\frac{1}{2}$ ;  $\frac{1}{2}-y, x+\frac{1}{2}, z+\frac{1}{2}$ ;  
 $y+\frac{1}{2}, x+\frac{1}{2}, \frac{1}{2}-z$ ;  
 $\frac{1}{2}-x, \frac{1}{2}-z, \frac{1}{2}-y$ ;  $\frac{1}{2}-x, z+\frac{1}{2}, y+\frac{1}{2}$ ;  $x+\frac{1}{2}, z+\frac{1}{2}, \frac{1}{2}-y$ ;  
 $x+\frac{1}{2}, \frac{1}{2}-z, y+\frac{1}{2}$ ;  
 $\frac{1}{2}-z, \frac{1}{2}-y, \frac{1}{2}-x$ ;  $z+\frac{1}{2}, y+\frac{1}{2}, \frac{1}{2}-x$ ;  $z+\frac{1}{2}, \frac{1}{2}-y, x+\frac{1}{2}$ ;  
 $\frac{1}{2}-z, y+\frac{1}{2}, x+\frac{1}{2}$ .

SPACE-GROUP  $O^3$ .

*Four* equivalent positions:

(a) 4b.            (b) 4c.

*Eight* equivalent positions:

(c) 8e.

*Twenty-four* equivalent positions:

(d) 24c.            (e) 24a.

*Thirty-two* equivalent positions:

(f) 32a.

*Forty-eight* equivalent positions:

(g) 48f.            (i) 48a.  
(h) 48g.

SPACE-GROUP  $O^3$  (continued).

Ninety-six equivalent positions:

- (j)  $xyz$ ;  $xy\bar{z}$ ;  $\bar{x}y\bar{z}$ ;  $\bar{x}\bar{y}z$ ;  
 $zxy$ ;  $\bar{z}x\bar{y}$ ;  $\bar{z}\bar{x}y$ ;  $z\bar{x}\bar{y}$ ;  
 $yxz$ ;  $\bar{y}\bar{z}x$ ;  $y\bar{z}\bar{x}$ ;  $\bar{y}z\bar{x}$ ;  
 $\bar{y}\bar{z}\bar{x}$ ;  $y\bar{z}x$ ;  $\bar{y}z\bar{x}$ ;  $y\bar{z}\bar{x}$ ;  
 $\bar{x}\bar{z}y$ ;  $\bar{x}zy$ ;  $\bar{x}z\bar{y}$ ;  $\bar{x}\bar{z}y$ ;  
 $\bar{z}y\bar{x}$ ;  $zy\bar{x}$ ;  $z\bar{y}x$ ;  $\bar{z}yx$ ;  
 $x+\frac{1}{2}, y+\frac{1}{2}, z$ ;  $x+\frac{1}{2}, \frac{1}{2}-y, \bar{z}$ ;  $\frac{1}{2}-x, y+\frac{1}{2}, \bar{z}$ ;  $\frac{1}{2}-x, \frac{1}{2}-y, z$ ;  
 $z+\frac{1}{2}, x+\frac{1}{2}, y$ ;  $\frac{1}{2}-z, x+\frac{1}{2}, \bar{y}$ ;  $\frac{1}{2}-z, \frac{1}{2}-x, y$ ;  $z+\frac{1}{2}, \frac{1}{2}-x, \bar{y}$ ;  
 $y+\frac{1}{2}, z+\frac{1}{2}, x$ ;  $\frac{1}{2}-y, \frac{1}{2}-z, x$ ;  $y+\frac{1}{2}, \frac{1}{2}-z, \bar{x}$ ;  $\frac{1}{2}-y, z+\frac{1}{2}, \bar{x}$ ;  
 $\frac{1}{2}-y, \frac{1}{2}-x, \bar{z}$ ;  $y+\frac{1}{2}, \frac{1}{2}-x, z$ ;  $\frac{1}{2}-y, x+\frac{1}{2}, z$ ;  $y+\frac{1}{2}, x+\frac{1}{2}, \bar{z}$ ;  
 $\frac{1}{2}-x, \frac{1}{2}-z, \bar{y}$ ;  $\frac{1}{2}-x, z+\frac{1}{2}, y$ ;  $x+\frac{1}{2}, z+\frac{1}{2}, \bar{y}$ ;  $x+\frac{1}{2}, \frac{1}{2}-z, y$ ;  
 $\frac{1}{2}-z, \frac{1}{2}-y, \bar{x}$ ;  $z+\frac{1}{2}, y+\frac{1}{2}, \bar{x}$ ;  $z+\frac{1}{2}, \frac{1}{2}-y, x$ ;  $\frac{1}{2}-z, y+\frac{1}{2}, x$ ;  
 $x+\frac{1}{2}, y, z+\frac{1}{2}$ ;  $x+\frac{1}{2}, \bar{y}, \frac{1}{2}-z$ ;  $\frac{1}{2}-x, y, \frac{1}{2}-z$ ;  $\frac{1}{2}-x, \bar{y}, z+\frac{1}{2}$ ;  
 $z+\frac{1}{2}, x, y+\frac{1}{2}$ ;  $\frac{1}{2}-z, x, \frac{1}{2}-y$ ;  $\frac{1}{2}-z, \bar{x}, y+\frac{1}{2}$ ;  $z+\frac{1}{2}, \bar{x}, \frac{1}{2}-y$ ;  
 $y+\frac{1}{2}, z, x+\frac{1}{2}$ ;  $\frac{1}{2}-y, z, x+\frac{1}{2}$ ;  $y+\frac{1}{2}, z, \frac{1}{2}-x$ ;  $\frac{1}{2}-y, z, \frac{1}{2}-x$ ;  
 $\frac{1}{2}-y, \bar{x}, \frac{1}{2}-z$ ;  $y+\frac{1}{2}, \bar{x}, z+\frac{1}{2}$ ;  $\frac{1}{2}-y, x, z+\frac{1}{2}$ ;  $y+\frac{1}{2}, x, \frac{1}{2}-z$ ;  
 $\frac{1}{2}-x, \bar{z}, \frac{1}{2}-y$ ;  $\frac{1}{2}-x, z, y+\frac{1}{2}$ ;  $x+\frac{1}{2}, z, \frac{1}{2}-y$ ;  $x+\frac{1}{2}, \bar{z}, y+\frac{1}{2}$ ;  
 $\frac{1}{2}-z, \bar{y}, \frac{1}{2}-x$ ;  $z+\frac{1}{2}, y, \frac{1}{2}-x$ ;  $z+\frac{1}{2}, \bar{y}, x+\frac{1}{2}$ ;  $\frac{1}{2}-z, y, x+\frac{1}{2}$ ;  
 $x, y+\frac{1}{2}, z+\frac{1}{2}$ ;  $x, \frac{1}{2}-y, \frac{1}{2}-z$ ;  $\bar{x}, y+\frac{1}{2}, \frac{1}{2}-z$ ;  $\bar{x}, \frac{1}{2}-y, z+\frac{1}{2}$ ;  
 $z, x+\frac{1}{2}, y+\frac{1}{2}$ ;  $\bar{z}, x+\frac{1}{2}, \frac{1}{2}-y$ ;  $\bar{z}, \frac{1}{2}-x, y+\frac{1}{2}$ ;  $z, \frac{1}{2}-x, \frac{1}{2}-y$ ;  
 $y, z+\frac{1}{2}, x+\frac{1}{2}$ ;  $\bar{y}, \frac{1}{2}-z, x+\frac{1}{2}$ ;  $y, \frac{1}{2}-z, \frac{1}{2}-x$ ;  $\bar{y}, z+\frac{1}{2}, \frac{1}{2}-x$ ;  
 $\bar{y}, \frac{1}{2}-x, \frac{1}{2}-z$ ;  $y, \frac{1}{2}-x, z+\frac{1}{2}$ ;  $\bar{y}, x+\frac{1}{2}, z+\frac{1}{2}$ ;  $y, x+\frac{1}{2}, \frac{1}{2}-z$ ;  
 $\bar{x}, \frac{1}{2}-z, \frac{1}{2}-y$ ;  $\bar{x}, z+\frac{1}{2}, y+\frac{1}{2}$ ;  $x, z+\frac{1}{2}, \frac{1}{2}-y$ ;  $x, \frac{1}{2}-z, y+\frac{1}{2}$ ;  
 $\bar{z}, \frac{1}{2}-y, \frac{1}{2}-x$ ;  $z, y+\frac{1}{2}, \frac{1}{2}-x$ ;  $z, \frac{1}{2}-y, x+\frac{1}{2}$ ;

SPACE-GROUP  $O^4$ .

Eight equivalent positions:

- (a) 8f. (b) 8g.

Sixteen equivalent positions:

- (c) 16b. (d) 16c.

Thirty-two equivalent positions:

- (e) 32b.

Forty-eight equivalent positions:

- (f) 48c. (g) 48h.

Ninety-six equivalent positions:

- (h)  $xyz$ ;  $xy\bar{z}$ ;  $\bar{x}y\bar{z}$ ;  $\bar{x}\bar{y}z$ ;  
 $zxy$ ;  $\bar{z}x\bar{y}$ ;  $\bar{z}\bar{x}y$ ;  $z\bar{x}\bar{y}$ ;  
 $yxz$ ;  $\bar{y}\bar{z}x$ ;  $y\bar{z}\bar{x}$ ;  $\bar{y}z\bar{x}$ ;  
 $\frac{1}{2}-y, \frac{1}{2}-x, \frac{1}{2}-z$ ;  $y+\frac{1}{2}, \frac{1}{2}-x, z+\frac{1}{2}$ ;  $\frac{1}{2}-y, x+\frac{1}{2}, z+\frac{1}{2}$ ;  
 $y+\frac{1}{2}, x+\frac{1}{2}, \frac{1}{2}-z$ ;  
 $\frac{1}{2}-x, \frac{1}{2}-z, \frac{1}{2}-y$ ;  $\frac{1}{2}-x, z+\frac{1}{2}, y+\frac{1}{2}$ ;  $x+\frac{1}{2}, z+\frac{1}{2}, \frac{1}{2}-y$ ;  
 $x+\frac{1}{2}, \frac{1}{2}-z, y+\frac{1}{2}$ ;

SPACE-GROUP  $O^4$  (continued).

$\frac{1}{2}-z, \frac{1}{2}-y, \frac{1}{2}-x; z+\frac{1}{2}, y+\frac{1}{2}, \frac{1}{2}-x; z+\frac{1}{2}, \frac{1}{2}-y, x+\frac{1}{2};$   
 $\frac{1}{2}-z, y+\frac{1}{2}, x+\frac{1}{2};$   
 $x+\frac{1}{2}, y+\frac{1}{2}, z; x+\frac{1}{2}, \frac{1}{2}-y, \bar{z}; \frac{1}{2}-x, y+\frac{1}{2}, \bar{x}; \frac{1}{2}-x, \frac{1}{2}-y, z;$   
 $z+\frac{1}{2}, x+\frac{1}{2}, y; \frac{1}{2}-z, x+\frac{1}{2}, \bar{y}; \frac{1}{2}-z, \frac{1}{2}-x, y; z+\frac{1}{2}, \frac{1}{2}-x, \bar{y};$   
 $y+\frac{1}{2}, z+\frac{1}{2}, x; \frac{1}{2}-y, \frac{1}{2}-z, x; y+\frac{1}{2}, \frac{1}{2}-z, \bar{x}; \frac{1}{2}-y, z+\frac{1}{2}, \bar{x};$   
 $\frac{1}{2}-y, \frac{1}{2}-x, \frac{1}{2}-z; y+\frac{1}{2}, \frac{1}{2}-x, z+\frac{1}{2}; \frac{1}{2}-y, x+\frac{1}{2}, z+\frac{1}{2};$   
 $y+\frac{1}{2}, x+\frac{1}{2}, \frac{1}{2}-z;$   
 $\frac{1}{2}-x, \frac{1}{2}-z, \frac{1}{2}-y; \frac{1}{2}-x, z+\frac{1}{2}, y+\frac{1}{2}; x+\frac{1}{2}, z+\frac{1}{2}, \frac{1}{2}-y;$   
 $x+\frac{1}{2}, \frac{1}{2}-z, y+\frac{1}{2};$   
 $\frac{1}{2}-z, \frac{1}{2}-y, \frac{1}{2}-x; z+\frac{1}{2}, y+\frac{1}{2}, \frac{1}{2}-x; z+\frac{1}{2}, \frac{1}{2}-y, x+\frac{1}{2};$   
 $\frac{1}{2}-z, y+\frac{1}{2}, x+\frac{1}{2};$   
 $x+\frac{1}{2}, y, z+\frac{1}{2}; x+\frac{1}{2}, \bar{y}, \frac{1}{2}-z; \frac{1}{2}-x, y, \frac{1}{2}-z; \frac{1}{2}-x, \bar{y}, z+\frac{1}{2};$   
 $z+\frac{1}{2}, x, y+\frac{1}{2}; \frac{1}{2}-z, x, \frac{1}{2}-y; \frac{1}{2}-z, \bar{x}, y+\frac{1}{2}; z+\frac{1}{2}, \bar{x}, \frac{1}{2}-y;$   
 $y+\frac{1}{2}, z, x+\frac{1}{2}; \frac{1}{2}-y, \bar{z}, x+\frac{1}{2}; y+\frac{1}{2}, \bar{z}, \frac{1}{2}-x; \frac{1}{2}-y, z, \frac{1}{2}-x;$   
 $\frac{1}{2}-y, \frac{1}{2}-x, \frac{1}{2}-z; y+\frac{1}{2}, \frac{1}{2}-x, z+\frac{1}{2}; \frac{1}{2}-y, x+\frac{1}{2}, z+\frac{1}{2};$   
 $y+\frac{1}{2}, x+\frac{1}{2}, \frac{1}{2}-z;$   
 $\frac{1}{2}-x, \frac{1}{2}-z, \frac{1}{2}-y; \frac{1}{2}-x, z+\frac{1}{2}, y+\frac{1}{2}; x+\frac{1}{2}, z+\frac{1}{2}, \frac{1}{2}-y;$   
 $x+\frac{1}{2}, \frac{1}{2}-z, y+\frac{1}{2};$   
 $\frac{1}{2}-z, \frac{1}{2}-y, \frac{1}{2}-x; z+\frac{1}{2}, y+\frac{1}{2}, \frac{1}{2}-x; z+\frac{1}{2}, \frac{1}{2}-y, x+\frac{1}{2};$   
 $\frac{1}{2}-z, y+\frac{1}{2}, x+\frac{1}{2};$   
 $x, y+\frac{1}{2}, z+\frac{1}{2}; x, \frac{1}{2}-y, \frac{1}{2}-z; \bar{x}, y+\frac{1}{2}, \frac{1}{2}-z; \bar{x}, \frac{1}{2}-y, z+\frac{1}{2};$   
 $z, x+\frac{1}{2}, y+\frac{1}{2}; \bar{z}, x+\frac{1}{2}, \frac{1}{2}-y; \bar{z}, \frac{1}{2}-x, y+\frac{1}{2}; z, \frac{1}{2}-x, \frac{1}{2}-y;$   
 $y, z+\frac{1}{2}, x+\frac{1}{2}; \bar{y}, \frac{1}{2}-z, x+\frac{1}{2}; y, \frac{1}{2}-z, \frac{1}{2}-x; \bar{y}, z+\frac{1}{2}, \frac{1}{2}-x;$   
 $\frac{1}{2}-y, \frac{1}{2}-x, \frac{1}{2}-z; y+\frac{1}{2}, \frac{1}{2}-x, z+\frac{1}{2}; \frac{1}{2}-y, x+\frac{1}{2}, z+\frac{1}{2};$   
 $y+\frac{1}{2}, x+\frac{1}{2}, \frac{1}{2}-z;$   
 $\frac{1}{2}-x, \frac{1}{2}-z, \frac{1}{2}-y; \frac{1}{2}-x, z+\frac{1}{2}, y+\frac{1}{2}; x+\frac{1}{2}, z+\frac{1}{2}, \frac{1}{2}-y;$   
 $x+\frac{1}{2}, \frac{1}{2}-z, y+\frac{1}{2};$   
 $\frac{1}{2}-z, \frac{1}{2}-y, \frac{1}{2}-x; z+\frac{1}{2}, y+\frac{1}{2}, \frac{1}{2}-x; z+\frac{1}{2}, \frac{1}{2}-y, x+\frac{1}{2};$   
 $\frac{1}{2}-z, y+\frac{1}{2}, x+\frac{1}{2}$

SPACE-GROUP  $O^5$ .

Two equivalent positions:

(a) 2a.

Six equivalent positions:

(b) 6e.

Eight equivalent positions:

(c) 8e.

Twelve equivalent positions:

(d) 12h. (f) 12b.

(e) 12a.

Sixteen equivalent positions:

(g) 16d.

SPACE-GROUP  $O^5$  (continued).*Twenty-four* equivalent positions:

(h) 24j.      (i) 24k.

*Forty-eight* equivalent positions:

(j)  $xyz$ ;  $xy\bar{z}$ ;  $\bar{x}y\bar{z}$ ;  $\bar{x}\bar{y}z$ ;  
 $zxy$ ;  $\bar{z}x\bar{y}$ ;  $\bar{z}\bar{x}y$ ;  $z\bar{x}\bar{y}$ ;  
 $yxz$ ;  $\bar{y}\bar{z}x$ ;  $y\bar{z}\bar{x}$ ;  $\bar{y}z\bar{x}$ ;  
 $\bar{y}\bar{z}\bar{x}$ ;  $y\bar{x}z$ ;  $\bar{y}xz$ ;  $y\bar{x}\bar{z}$ ;  
 $\bar{y}\bar{x}\bar{z}$ ;  $\bar{x}zy$ ;  $\bar{x}z\bar{y}$ ;  $\bar{x}\bar{z}y$ ;  
 $\bar{x}\bar{z}\bar{y}$ ;  $z\bar{y}x$ ;  $z\bar{y}\bar{x}$ ;  $\bar{z}y\bar{x}$ ;  
 $x+\frac{1}{2}, y+\frac{1}{2}, z+\frac{1}{2}$ ;  $x+\frac{1}{2}, \frac{1}{2}-y, \frac{1}{2}-z$ ;  $\frac{1}{2}-x, y+\frac{1}{2}, \frac{1}{2}-z$ ;  
 $\frac{1}{2}-x, \frac{1}{2}-y, z+\frac{1}{2}$ ;  
 $z+\frac{1}{2}, x+\frac{1}{2}, y+\frac{1}{2}$ ;  $\frac{1}{2}-z, x+\frac{1}{2}, \frac{1}{2}-y$ ;  $\frac{1}{2}-z, \frac{1}{2}-x, y+\frac{1}{2}$ ;  
 $z+\frac{1}{2}, \frac{1}{2}-x, \frac{1}{2}-y$ ;  
 $y+\frac{1}{2}, z+\frac{1}{2}, x+\frac{1}{2}$ ;  $\frac{1}{2}-y, \frac{1}{2}-z, x+\frac{1}{2}$ ;  $y+\frac{1}{2}, \frac{1}{2}-z, \frac{1}{2}-x$ ;  
 $\frac{1}{2}-y, z+\frac{1}{2}, \frac{1}{2}-x$ ;  
 $\frac{1}{2}-y, \frac{1}{2}-x, \frac{1}{2}-z$ ;  $y+\frac{1}{2}, \frac{1}{2}-x, z+\frac{1}{2}$ ;  $\frac{1}{2}-y, x+\frac{1}{2}, z+\frac{1}{2}$ ;  
 $y+\frac{1}{2}, x+\frac{1}{2}, \frac{1}{2}-z$ ;  
 $\frac{1}{2}-x, \frac{1}{2}-z, \frac{1}{2}-y$ ;  $\frac{1}{2}-x, z+\frac{1}{2}, y+\frac{1}{2}$ ;  $x+\frac{1}{2}, z+\frac{1}{2}, \frac{1}{2}-y$ ;  
 $x+\frac{1}{2}, \frac{1}{2}-z, y+\frac{1}{2}$ ;  
 $\frac{1}{2}-z, \frac{1}{2}-y, \frac{1}{2}-x$ ;  $z+\frac{1}{2}, y+\frac{1}{2}, \frac{1}{2}-x$ ;  $z+\frac{1}{2}, \frac{1}{2}-y, x+\frac{1}{2}$ ;  
 $\frac{1}{2}-z, y+\frac{1}{2}, x+\frac{1}{2}$ .

SPACE-GROUP  $O^6$ .*Four* equivalent positions:

(a) 4g.      (b) 4h.

*Eight* equivalent positions:

(c) 8j.

*Twelve* equivalent positions:

(d) 12q.

*Twenty-four* equivalent positions:

(e)  $xyz$ ;  $x+\frac{1}{2}, \frac{1}{2}-y, \bar{z}$ ;  $\bar{x}, y+\frac{1}{2}, \frac{1}{2}-z$ ;  $\frac{1}{2}-x, \bar{y}, z+\frac{1}{2}$ ;  
 $zxy$ ;  $\bar{z}, x+\frac{1}{2}, \frac{1}{2}-y$ ;  $\frac{1}{2}-z, \bar{x}, y+\frac{1}{2}$ ;  $z+\frac{1}{2}, \frac{1}{2}-x, \bar{y}$ ;  
 $yxz$ ;  $\frac{1}{2}-y, \bar{z}, x+\frac{1}{2}$ ;  $y+\frac{1}{2}, \frac{1}{2}-z, \bar{x}$ ;  $\bar{y}, z+\frac{1}{2}, \frac{1}{2}-x$ ;  
 $\frac{1}{2}-y, \frac{1}{2}-x, \frac{1}{2}-z$ ;  $y+\frac{1}{2}, \frac{1}{2}-x, z+\frac{1}{2}$ ;  $\frac{1}{2}-y, x+\frac{1}{2}, z+\frac{1}{2}$ ;  
 $y+\frac{1}{2}, x+\frac{1}{2}, \frac{1}{2}-z$ ;  
 $\frac{1}{2}-x, \frac{1}{2}-z, \frac{1}{2}-y$ ;  $\frac{1}{2}-x, z+\frac{1}{2}, y+\frac{1}{2}$ ;  $x+\frac{1}{2}, z+\frac{1}{2}, \frac{1}{2}-y$ ;  
 $x+\frac{1}{2}, \frac{1}{2}-z, y+\frac{1}{2}$ ;  
 $\frac{1}{2}-z, \frac{1}{2}-y, \frac{1}{2}-x$ ;  $z+\frac{1}{2}, y+\frac{1}{2}, \frac{1}{2}-x$ ;  $z+\frac{1}{2}, \frac{1}{2}-y, x+\frac{1}{2}$ ;  
 $\frac{1}{2}-z, y+\frac{1}{2}, x+\frac{1}{2}$ .

It is evident that a suitable transformation would simplify the two unique cases.

SPACE-GROUP  $O^7$ .

Four equivalent positions:

- (a) 4i. (b) 4j.

Eight equivalent positions:

- (c) 8k.

Twelve equivalent positions:

- (d) 12r.

Twenty-four equivalent positions:

- (e)  $xyz$ ;  $x+\frac{1}{2}, \frac{1}{2}-y, \bar{z}$ ;  $\bar{x}, y+\frac{1}{2}, \frac{1}{2}-z$ ;  $\frac{1}{2}-x, \bar{y}, z+\frac{1}{2}$ ;  
 $zxy$ ;  $\bar{z}, x+\frac{1}{2}, \frac{1}{2}-y$ ;  $\frac{1}{2}-z, \bar{x}, y+\frac{1}{2}$ ;  $z+\frac{1}{2}, \frac{1}{2}-x, \bar{y}$ ;  
 $yzx$ ;  $\frac{1}{2}-y, \bar{z}, x+\frac{1}{2}$ ;  $y+\frac{1}{2}, \frac{1}{2}-z, \bar{x}$ ;  $\bar{y}, z+\frac{1}{2}, \frac{1}{2}-x$ ;  
 $\frac{1}{2}-y, \frac{1}{2}-x, \frac{1}{2}-z$ ;  $y+\frac{1}{2}, \frac{1}{2}-x, z+\frac{1}{2}$ ;  $\frac{1}{2}-y, x+\frac{1}{2}, z+\frac{1}{2}$ ;  
 $y+\frac{1}{2}, x+\frac{1}{2}, \frac{1}{2}-z$ ;  
 $\frac{1}{2}-x, \frac{1}{2}-z, \frac{1}{2}-y$ ;  $\frac{1}{2}-x, z+\frac{1}{2}, y+\frac{1}{2}$ ;  $x+\frac{1}{2}, z+\frac{1}{2}, \frac{1}{2}-y$ ;  
 $x+\frac{1}{2}, \frac{1}{2}-z, y+\frac{1}{2}$ ;  
 $\frac{1}{2}-z, \frac{1}{2}-y, \frac{1}{2}-x$ ;  $z+\frac{1}{2}, y+\frac{1}{2}, \frac{1}{2}-x$ ;  $z+\frac{1}{2}, \frac{1}{2}-y, z+\frac{1}{2}$ ;  
 $\frac{1}{2}-z, y+\frac{1}{2}, x+\frac{1}{2}$ .

SPACE-GROUP  $O^8$ .

Eight equivalent positions:

- (a) 8l. (b) 8m.

Twelve equivalent positions:

- (c) 12s. (d) 12l.

Sixteen equivalent positions:

- (e) 16g.

Twenty-four equivalent positions:

- (f) 24l. (g) 24m. (h) 24n.

Forty-eight equivalent positions:

- (i)  $xyz$ ;  $x, \bar{y}, \frac{1}{2}-z$ ;  $\frac{1}{2}-x, y, \bar{z}$ ;  $\bar{x}, \frac{1}{2}-y, z$ ;  
 $zxy$ ;  $\frac{1}{2}-z, x, \bar{y}$ ;  $\bar{z}, \frac{1}{2}-x, y$ ;  $z, \bar{x}, \frac{1}{2}-y$ ;  
 $yzx$ ;  $\bar{y}, \frac{1}{2}-z, x$ ;  $y, \bar{z}, \frac{1}{2}-x$ ;  $\frac{1}{2}-y, z, \bar{x}$ ;  
 $\frac{1}{2}-y, \frac{1}{2}-x, \frac{1}{2}-z$ ;  $y+\frac{1}{2}, \frac{1}{2}-x, z+\frac{1}{2}$ ;  $\frac{1}{2}-y, x+\frac{1}{2}, z+\frac{1}{2}$ ;  
 $y+\frac{1}{2}, x+\frac{1}{2}, \frac{1}{2}-z$ ;  
 $\frac{1}{2}-x, \frac{1}{2}-z, \frac{1}{2}-y$ ;  $\frac{1}{2}-x, z+\frac{1}{2}, y+\frac{1}{2}$ ;  $x+\frac{1}{2}, z+\frac{1}{2}, \frac{1}{2}-y$ ;  
 $x+\frac{1}{2}, \frac{1}{2}-z, y+\frac{1}{2}$ ;  
 $\frac{1}{2}-z, \frac{1}{2}-y, \frac{1}{2}-x$ ;  $z+\frac{1}{2}, y+\frac{1}{2}, \frac{1}{2}-x$ ;  $z+\frac{1}{2}, \frac{1}{2}-y, x+\frac{1}{2}$ ;  
 $\frac{1}{2}-z, y+\frac{1}{2}, x+\frac{1}{2}$ ;  
 $x+\frac{1}{2}, y+\frac{1}{2}, z+\frac{1}{2}$ ;  $x+\frac{1}{2}, \frac{1}{2}-y, \bar{z}$ ;  $\bar{x}, y+\frac{1}{2}, \frac{1}{2}-z$ ;  
 $\frac{1}{2}-x, \bar{y}, z+\frac{1}{2}$ ;



SPACE-GROUP  $O^8$  (continued).

$$\begin{array}{l}
z+\frac{1}{2}, x+\frac{1}{2}, y+\frac{1}{2}; \quad \bar{z}, x+\frac{1}{2}, \frac{1}{2}-y; \quad \frac{1}{2}-z, \bar{x}, y+\frac{1}{2}; \\
\phantom{z+\frac{1}{2}, x+\frac{1}{2}, y+\frac{1}{2};} \phantom{\bar{z}, x+\frac{1}{2}, \frac{1}{2}-y;} \phantom{\frac{1}{2}-z, \bar{x}, y+\frac{1}{2};} \phantom{z+\frac{1}{2}, x+\frac{1}{2}, y+\frac{1}{2};} z+\frac{1}{2}, \frac{1}{2}-x, \bar{y}; \\
y+\frac{1}{2}, z+\frac{1}{2}, x+\frac{1}{2}; \quad \frac{1}{2}-y, \bar{z}, x+\frac{1}{2}; \quad y+\frac{1}{2}, \frac{1}{2}-z, \bar{x}; \\
\phantom{y+\frac{1}{2}, z+\frac{1}{2}, x+\frac{1}{2};} \phantom{\frac{1}{2}-y, \bar{z}, x+\frac{1}{2};} \phantom{y+\frac{1}{2}, \frac{1}{2}-z, \bar{x};} \phantom{z+\frac{1}{2}, x+\frac{1}{2}, y+\frac{1}{2};} \bar{y}, z+\frac{1}{2}, \frac{1}{2}-x; \\
\frac{1}{2}-y, \frac{1}{2}-x, \frac{1}{2}-z; \quad y+\frac{1}{2}, \frac{1}{2}-x, z+\frac{1}{2}; \quad \frac{1}{2}-y, x+\frac{1}{2}, z+\frac{1}{2}; \\
\phantom{\frac{1}{2}-y, \frac{1}{2}-x, \frac{1}{2}-z;} \phantom{y+\frac{1}{2}, \frac{1}{2}-x, z+\frac{1}{2};} \phantom{\frac{1}{2}-y, x+\frac{1}{2}, z+\frac{1}{2};} \phantom{z+\frac{1}{2}, x+\frac{1}{2}, y+\frac{1}{2};} y+\frac{1}{2}, x+\frac{1}{2}, \frac{1}{2}-z; \\
\frac{1}{2}-x, \frac{1}{2}-z, \frac{1}{2}-y; \quad \frac{1}{2}-x, z+\frac{1}{2}, y+\frac{1}{2}; \quad x+\frac{1}{2}, z+\frac{1}{2}, \frac{1}{2}-y; \\
\phantom{\frac{1}{2}-x, \frac{1}{2}-z, \frac{1}{2}-y;} \phantom{\frac{1}{2}-x, z+\frac{1}{2}, y+\frac{1}{2};} \phantom{x+\frac{1}{2}, z+\frac{1}{2}, \frac{1}{2}-y;} \phantom{z+\frac{1}{2}, x+\frac{1}{2}, y+\frac{1}{2};} x+\frac{1}{2}, \frac{1}{2}-z, y+\frac{1}{2}; \\
\frac{1}{2}-z, \frac{1}{2}-y, \frac{1}{2}-x; \quad z+\frac{1}{2}, y+\frac{1}{2}, \frac{1}{2}-x; \quad z+\frac{1}{2}, \frac{1}{2}-y, x+\frac{1}{2}; \\
\phantom{\frac{1}{2}-z, \frac{1}{2}-y, \frac{1}{2}-x;} \phantom{z+\frac{1}{2}, y+\frac{1}{2}, \frac{1}{2}-x;} \phantom{z+\frac{1}{2}, \frac{1}{2}-y, x+\frac{1}{2};} \phantom{z+\frac{1}{2}, x+\frac{1}{2}, y+\frac{1}{2};} \frac{1}{2}-z, y+\frac{1}{2}, x+\frac{1}{2}.
\end{array}$$

## E. HOLOHEDRY.

SPACE-GROUP  $O_2^1$ .

One equivalent position:

(a) 1a.            (b) 1b.

Three equivalent positions:

(c) 3a.            (d) 3b.

Six equivalent positions:

(e) 6a.            (f) 6d.

Eight equivalent positions:

(g) 8c.

Twelve equivalent positions:

(h) 12f.            (j) 12n.

(i) 12m.

Twenty-four equivalent positions:

(k) 24o.            (m) 24q.

(l) 24p.

Forty-eight equivalent positions:

(n)  $xyz; \quad x\bar{y}\bar{z}; \quad \bar{x}y\bar{z}; \quad \bar{x}\bar{y}z;$   
 $zxy; \quad \bar{z}x\bar{y}; \quad \bar{z}\bar{x}y; \quad z\bar{x}\bar{y};$   
 $yzx; \quad \bar{y}\bar{z}x; \quad y\bar{z}\bar{x}; \quad \bar{y}z\bar{x};$   
 $\bar{y}\bar{x}\bar{z}; \quad y\bar{x}z; \quad \bar{y}xz; \quad yx\bar{z};$   
 $\bar{x}\bar{z}\bar{y}; \quad \bar{x}zy; \quad xz\bar{y}; \quad x\bar{z}y;$   
 $\bar{z}\bar{y}\bar{x}; \quad zy\bar{x}; \quad z\bar{y}x; \quad \bar{z}yx;$   
 $\bar{x}\bar{y}\bar{z}; \quad \bar{x}yz; \quad x\bar{y}z; \quad xy\bar{z};$   
 $\bar{z}\bar{x}\bar{y}; \quad z\bar{x}y; \quad zxy; \quad \bar{z}xy;$   
 $\bar{y}\bar{z}\bar{x}; \quad yz\bar{x}; \quad \bar{y}zx; \quad y\bar{z}x;$   
 $yxz; \quad \bar{y}x\bar{z}; \quad y\bar{x}\bar{z}; \quad \bar{y}\bar{x}z;$   
 $zxy; \quad x\bar{z}\bar{y}; \quad \bar{x}\bar{z}y; \quad \bar{x}z\bar{y};$   
 $zyx; \quad \bar{z}\bar{y}x; \quad \bar{z}y\bar{x}; \quad z\bar{y}\bar{x};$

SPACE GROUP  $O_h^2$ .

*Two* equivalent positions:

(a) 2a.

*Six* equivalent positions:

(b) 6e.

*Eight* equivalent positions:

(c) 8e.

*Twelve* equivalent positions:

(d) 12h. (e) 12a.

*Sixteen* equivalent positions:

(f) 16d.

*Twenty-four* equivalent positions:

(g) 24f. (h) 24j.

*Forty-eight* equivalent positions:

- (i)  $xyz$ ;  $x\bar{y}\bar{z}$ ;  $\bar{x}y\bar{z}$ ;  $\bar{x}\bar{y}z$ ;  
 $zxy$ ;  $\bar{z}x\bar{y}$ ;  $\bar{z}\bar{x}y$ ;  $z\bar{x}\bar{y}$ ;  
 $yzx$ ;  $\bar{y}\bar{z}x$ ;  $y\bar{z}\bar{x}$ ;  $\bar{y}z\bar{x}$ ;  
 $\bar{y}\bar{z}\bar{x}$ ;  $y\bar{x}z$ ;  $\bar{y}xz$ ;  $yx\bar{z}$ ;  
 $\bar{x}\bar{z}\bar{y}$ ;  $\bar{x}zy$ ;  $xz\bar{y}$ ;  $x\bar{z}y$ ;  
 $\bar{z}y\bar{x}$ ;  $zy\bar{x}$ ;  $z\bar{y}x$ ;  $\bar{z}yx$ ;  
 $\frac{1}{2}-x, \frac{1}{2}-y, \frac{1}{2}-z$ ;  $\frac{1}{2}-x, y+\frac{1}{2}, z+\frac{1}{2}$ ;  $x+\frac{1}{2}, \frac{1}{2}-y, z+\frac{1}{2}$ ;  
 $x+\frac{1}{2}, y+\frac{1}{2}, \frac{1}{2}-z$ ;  
 $\frac{1}{2}-z, \frac{1}{2}-x, \frac{1}{2}-y$ ;  $z+\frac{1}{2}, \frac{1}{2}-x, y+\frac{1}{2}$ ;  $z+\frac{1}{2}, x+\frac{1}{2}, \frac{1}{2}-y$ ;  
 $\frac{1}{2}-z, x+\frac{1}{2}, y+\frac{1}{2}$ ;  
 $\frac{1}{2}-y, \frac{1}{2}-z, \frac{1}{2}-x$ ;  $y+\frac{1}{2}, z+\frac{1}{2}, \frac{1}{2}-x$ ;  $\frac{1}{2}-y, z+\frac{1}{2}, x+\frac{1}{2}$ ;  
 $y+\frac{1}{2}, \frac{1}{2}-z, x+\frac{1}{2}$ ;  
 $y+\frac{1}{2}, x+\frac{1}{2}, z+\frac{1}{2}$ ;  $\frac{1}{2}-y, x+\frac{1}{2}, \frac{1}{2}-z$ ;  $y+\frac{1}{2}, \frac{1}{2}-x, \frac{1}{2}-z$ ;  
 $\frac{1}{2}-y, \frac{1}{2}-x, z+\frac{1}{2}$ ;  
 $x+\frac{1}{2}, z+\frac{1}{2}, y+\frac{1}{2}$ ;  $x+\frac{1}{2}, \frac{1}{2}-z, \frac{1}{2}-y$ ;  $\frac{1}{2}-x, \frac{1}{2}-z, y+\frac{1}{2}$ ;  
 $\frac{1}{2}-x, z+\frac{1}{2}, \frac{1}{2}-y$ ;  
 $z+\frac{1}{2}, y+\frac{1}{2}, x+\frac{1}{2}$ ;  $\frac{1}{2}-z, \frac{1}{2}-y, x+\frac{1}{2}$ ;  $\frac{1}{2}-z, y+\frac{1}{2}, \frac{1}{2}-x$ ;  
 $z+\frac{1}{2}, \frac{1}{2}-y, \frac{1}{2}-x$ .

SPACE-GROUP  $O_h^3$ .

*Two* equivalent positions:

(a) 2a.

*Six* equivalent positions:

(b) 6e. (c) 6f. (d) 6g.

*Eight* equivalent positions:

(e) 8e.

SPACE-GROUP  $O_h^2$  (continued).*Twelve* equivalent positions:

(f) 12a.            (g) 12i.            (h) 12j.

*Sixteen* equivalent positions:

(i) 16d.

*Twenty-four* equivalent positions:

(j) 24a.            (k) 24r.

*Forty-eight* equivalent positions:

(l)  $xyz; \quad x\bar{y}\bar{z}; \quad \bar{x}y\bar{z}; \quad \bar{x}\bar{y}z;$   
 $zxy; \quad \bar{z}x\bar{y}; \quad \bar{z}\bar{x}y; \quad z\bar{x}\bar{y};$   
 $yzx; \quad \bar{y}\bar{z}x; \quad y\bar{z}\bar{x}; \quad \bar{y}z\bar{x};$   
 $\frac{1}{2}-y, \frac{1}{2}-x, \frac{1}{2}-z; \quad y+\frac{1}{2}, \frac{1}{2}-x, z+\frac{1}{2}; \quad \frac{1}{2}-y, x+\frac{1}{2}, z+\frac{1}{2};$   
 $\qquad\qquad\qquad y+\frac{1}{2}, x+\frac{1}{2}, \frac{1}{2}-z;$   
 $\frac{1}{2}-x, \frac{1}{2}-z, \frac{1}{2}-y; \quad \frac{1}{2}-x, z+\frac{1}{2}, y+\frac{1}{2}; \quad x+\frac{1}{2}, z+\frac{1}{2}, \frac{1}{2}-y;$   
 $\qquad\qquad\qquad x+\frac{1}{2}, \frac{1}{2}-z, y+\frac{1}{2};$   
 $\frac{1}{2}-z, \frac{1}{2}-y, \frac{1}{2}-x; \quad z+\frac{1}{2}, y+\frac{1}{2}, \frac{1}{2}-x; \quad z+\frac{1}{2}, \frac{1}{2}-y, x+\frac{1}{2};$   
 $\qquad\qquad\qquad \frac{1}{2}-z, y+\frac{1}{2}, x+\frac{1}{2};$   
 $\bar{x}y\bar{z}; \quad \bar{x}\bar{y}z; \quad x\bar{y}\bar{z}; \quad xy\bar{z};$   
 $\bar{z}x\bar{y}; \quad z\bar{x}\bar{y}; \quad z\bar{x}y; \quad \bar{z}xy;$   
 $\bar{y}\bar{z}\bar{x}; \quad y\bar{z}x; \quad \bar{y}zx; \quad y\bar{z}x;$   
 $y+\frac{1}{2}, x+\frac{1}{2}, z+\frac{1}{2}; \quad \frac{1}{2}-y, x+\frac{1}{2}, \frac{1}{2}-z; \quad y+\frac{1}{2}, \frac{1}{2}-x, \frac{1}{2}-z;$   
 $\qquad\qquad\qquad \frac{1}{2}-y, \frac{1}{2}-x, z+\frac{1}{2};$   
 $x+\frac{1}{2}, z+\frac{1}{2}, y+\frac{1}{2}; \quad x+\frac{1}{2}, \frac{1}{2}-z, \frac{1}{2}-y; \quad \frac{1}{2}-x, \frac{1}{2}-z, y+\frac{1}{2};$   
 $\qquad\qquad\qquad \frac{1}{2}-x, z+\frac{1}{2}, \frac{1}{2}-y;$   
 $z+\frac{1}{2}, y+\frac{1}{2}, x+\frac{1}{2}; \quad \frac{1}{2}-z, \frac{1}{2}-y, x+\frac{1}{2}; \quad \frac{1}{2}-z, y+\frac{1}{2}, \frac{1}{2}-x;$   
 $\qquad\qquad\qquad z+\frac{1}{2}, \frac{1}{2}-y, \frac{1}{2}-x.$

SPACE-GROUP  $O_h^4$ .*Two* equivalent positions:

(a) 2a.

*Four* equivalent positions:

(b) 4d.            (c) 4e.

*Six* equivalent positions:

(d) 6e.

*Eight* equivalent positions:

(e) 8d.

*Twelve* equivalent positions:

(f) 12h.            (g) 12a.

*Twenty-four* equivalent positions:

(h) 24f.            (i) 24t.            (j) 24u.

SPACE-GROUP  $O_h^4$  (continued).

Forty-eight equivalent positions:

- (k)  $xyz; \quad x\bar{y}\bar{z}; \quad \bar{x}y\bar{z}; \quad \bar{x}\bar{y}z;$   
 $zxy; \quad \bar{z}x\bar{y}; \quad \bar{z}\bar{x}y; \quad z\bar{x}\bar{y};$   
 $yzx; \quad \bar{y}\bar{z}x; \quad y\bar{z}\bar{x}; \quad \bar{y}z\bar{x};$   
 $\frac{1}{2}-y, \frac{1}{2}-x, \frac{1}{2}-z; \quad y+\frac{1}{2}, \frac{1}{2}-x, z+\frac{1}{2}; \quad \frac{1}{2}-y, x+\frac{1}{2}, z+\frac{1}{2};$   
 $y+\frac{1}{2}, x+\frac{1}{2}, \frac{1}{2}-z;$   
 $\frac{1}{2}-x, \frac{1}{2}-z, \frac{1}{2}-y; \quad \frac{1}{2}-x, z+\frac{1}{2}, y+\frac{1}{2}; \quad x+\frac{1}{2}, z+\frac{1}{2}, \frac{1}{2}-y;$   
 $x+\frac{1}{2}, \frac{1}{2}-z, y+\frac{1}{2};$   
 $\frac{1}{2}-z, \frac{1}{2}-y, \frac{1}{2}-x; \quad z+\frac{1}{2}, y+\frac{1}{2}, \frac{1}{2}-x; \quad z+\frac{1}{2}, \frac{1}{2}-y, x+\frac{1}{2};$   
 $\frac{1}{2}-z, y+\frac{1}{2}, x+\frac{1}{2};$   
 $\frac{1}{2}-x, \frac{1}{2}-y, \frac{1}{2}-z; \quad \frac{1}{2}-x, y+\frac{1}{2}, z+\frac{1}{2}; \quad x+\frac{1}{2}, \frac{1}{2}-y, z+\frac{1}{2};$   
 $x+\frac{1}{2}, y+\frac{1}{2}, \frac{1}{2}-z;$   
 $\frac{1}{2}-z, \frac{1}{2}-x, \frac{1}{2}-y; \quad z+\frac{1}{2}, \frac{1}{2}-x, y+\frac{1}{2}; \quad z+\frac{1}{2}, x+\frac{1}{2}, \frac{1}{2}-y;$   
 $\frac{1}{2}-z, x+\frac{1}{2}, y+\frac{1}{2};$   
 $\frac{1}{2}-y, \frac{1}{2}-z, \frac{1}{2}-x; \quad y+\frac{1}{2}, z+\frac{1}{2}, \frac{1}{2}-x; \quad \frac{1}{2}-y, z+\frac{1}{2}, x+\frac{1}{2};$   
 $y+\frac{1}{2}, \frac{1}{2}-z, x+\frac{1}{2};$   
 $yxz; \quad \bar{y}x\bar{z}; \quad y\bar{x}\bar{z}; \quad \bar{y}\bar{x}z;$   
 $xzy; \quad x\bar{z}\bar{y}; \quad \bar{x}\bar{z}y; \quad \bar{x}z\bar{y};$   
 $zyx; \quad \bar{z}\bar{y}x; \quad \bar{z}y\bar{x}; \quad z\bar{y}\bar{x}.$

SPACE-GROUP  $O_h^5$ .

Four equivalent positions:

- (a) 4b.            (b) 4c.

Eight equivalent positions:

- (c) 8e.

Twenty-four equivalent positions:

- (d) 24c.            (e) 24a.

Thirty-two equivalent positions:

- (f) 32a.

Forty-eight equivalent positions:

- (g) 48a.            (h) 48f.            (i) 48g.

Ninety-six equivalent positions:

- (j) 96a.            (k) 96b.

One hundred ninety-two equivalent positions:

- (l)  $xyz; \quad x\bar{y}\bar{z}; \quad \bar{x}y\bar{z}; \quad \bar{x}\bar{y}z;$   
 $zxy; \quad \bar{z}x\bar{y}; \quad \bar{z}\bar{x}y; \quad z\bar{x}\bar{y};$   
 $yzx; \quad \bar{y}\bar{z}x; \quad y\bar{z}\bar{x}; \quad \bar{y}z\bar{x};$   
 $\bar{y}\bar{x}\bar{z}; \quad y\bar{x}z; \quad \bar{y}xz; \quad yx\bar{z};$   
 $\bar{x}\bar{z}\bar{y}; \quad \bar{x}zy; \quad xz\bar{y}; \quad x\bar{z}y;$   
 $\bar{z}\bar{y}\bar{x}; \quad zy\bar{x}; \quad z\bar{y}x; \quad \bar{z}yx;$   
 $\bar{x}\bar{y}\bar{z}; \quad \bar{x}yz; \quad x\bar{y}z; \quad xy\bar{z};$   
 $\bar{z}\bar{x}\bar{y}; \quad \bar{z}xy; \quad z\bar{x}y; \quad \bar{z}xy;$

SPACE-GROUP  $O_h^5$  (continued).

$\bar{y}\bar{z}\bar{x}$ ;	$y\bar{z}\bar{x}$ ;	$\bar{y}zx$ ;	$y\bar{z}x$ ;
$yxz$ ;	$\bar{y}x\bar{z}$ ;	$y\bar{x}\bar{z}$ ;	$\bar{y}\bar{x}z$ ;
$xzy$ ;	$x\bar{z}\bar{y}$ ;	$\bar{x}\bar{z}y$ ;	$\bar{x}z\bar{y}$ ;
$zyx$ ;	$\bar{z}\bar{y}\bar{x}$ ;	$\bar{z}y\bar{x}$ ;	$z\bar{y}\bar{x}$ ;
$x+\frac{1}{2}, y+\frac{1}{2}, z$ ;	$x+\frac{1}{2}, \frac{1}{2}-y, \bar{z}$ ;	$\frac{1}{2}-x, y+\frac{1}{2}, \bar{z}$ ;	$\frac{1}{2}-x, \frac{1}{2}-y, z$ ;
$z+\frac{1}{2}, x+\frac{1}{2}, y$ ;	$\frac{1}{2}-z, x+\frac{1}{2}, \bar{y}$ ;	$\frac{1}{2}-z, \frac{1}{2}-x, y$ ;	$z+\frac{1}{2}, \frac{1}{2}-x, \bar{y}$ ;
$y+\frac{1}{2}, z+\frac{1}{2}, x$ ;	$\frac{1}{2}-y, \frac{1}{2}-z, x$ ;	$y+\frac{1}{2}, \frac{1}{2}-z, \bar{x}$ ;	$\frac{1}{2}-y, z+\frac{1}{2}, \bar{x}$ ;
$\frac{1}{2}-y, \frac{1}{2}-x, \bar{z}$ ;	$y+\frac{1}{2}, \frac{1}{2}-x, z$ ;	$\frac{1}{2}-y, x+\frac{1}{2}, z$ ;	$y+\frac{1}{2}, x+\frac{1}{2}, \bar{z}$ ;
$\frac{1}{2}-x, \frac{1}{2}-z, \bar{y}$ ;	$\frac{1}{2}-x, z+\frac{1}{2}, y$ ;	$x+\frac{1}{2}, z+\frac{1}{2}, \bar{y}$ ;	$x+\frac{1}{2}, \frac{1}{2}-z, y$ ;
$\frac{1}{2}-z, \frac{1}{2}-y, \bar{x}$ ;	$z+\frac{1}{2}, y+\frac{1}{2}, \bar{x}$ ;	$z+\frac{1}{2}, \frac{1}{2}-y, x$ ;	$\frac{1}{2}-z, y+\frac{1}{2}, x$ ;
$\frac{1}{2}-x, \frac{1}{2}-y, \bar{z}$ ;	$\frac{1}{2}-x, y+\frac{1}{2}, z$ ;	$x+\frac{1}{2}, \frac{1}{2}-y, z$ ;	$x+\frac{1}{2}, y+\frac{1}{2}, \bar{z}$ ;
$\frac{1}{2}-z, \frac{1}{2}-x, \bar{y}$ ;	$z+\frac{1}{2}, \frac{1}{2}-x, y$ ;	$z+\frac{1}{2}, x+\frac{1}{2}, \bar{y}$ ;	$\frac{1}{2}-z, x+\frac{1}{2}, y$ ;
$\frac{1}{2}-y, \frac{1}{2}-z, \bar{x}$ ;	$y+\frac{1}{2}, z+\frac{1}{2}, \bar{x}$ ;	$\frac{1}{2}-y, z+\frac{1}{2}, x$ ;	$y+\frac{1}{2}, \frac{1}{2}-z, x$ ;
$y+\frac{1}{2}, x+\frac{1}{2}, z$ ;	$\frac{1}{2}-y, x+\frac{1}{2}, \bar{z}$ ;	$y+\frac{1}{2}, \frac{1}{2}-x, \bar{z}$ ;	$\frac{1}{2}-y, \frac{1}{2}-x, z$ ;
$x+\frac{1}{2}, z+\frac{1}{2}, y$ ;	$x+\frac{1}{2}, \frac{1}{2}-z, \bar{y}$ ;	$\frac{1}{2}-x, \frac{1}{2}-z, y$ ;	$\frac{1}{2}-x, z+\frac{1}{2}, \bar{y}$ ;
$z+\frac{1}{2}, y+\frac{1}{2}, x$ ;	$\frac{1}{2}-z, \frac{1}{2}-y, x$ ;	$\frac{1}{2}-z, y+\frac{1}{2}, \bar{x}$ ;	$z+\frac{1}{2}, \frac{1}{2}-y, \bar{x}$ ;
$x+\frac{1}{2}, y, z+\frac{1}{2}$ ;	$x+\frac{1}{2}, \bar{y}, \frac{1}{2}-z$ ;	$\frac{1}{2}-x, y, \frac{1}{2}-z$ ;	$\frac{1}{2}-x, \bar{y}, z+\frac{1}{2}$ ;
$z+\frac{1}{2}, x, y+\frac{1}{2}$ ;	$\frac{1}{2}-z, x, \frac{1}{2}-y$ ;	$\frac{1}{2}-z, \bar{x}, y+\frac{1}{2}$ ;	$z+\frac{1}{2}, \bar{x}, \frac{1}{2}-y$ ;
$y+\frac{1}{2}, z, x+\frac{1}{2}$ ;	$\frac{1}{2}-y, \bar{z}, x+\frac{1}{2}$ ;	$y+\frac{1}{2}, \bar{z}, \frac{1}{2}-x$ ;	$\frac{1}{2}-y, z, \frac{1}{2}-x$ ;
$\frac{1}{2}-y, \bar{x}, \frac{1}{2}-z$ ;	$y+\frac{1}{2}, \bar{x}, z+\frac{1}{2}$ ;	$\frac{1}{2}-y, x, z+\frac{1}{2}$ ;	$y+\frac{1}{2}, x, \frac{1}{2}-z$ ;
$\frac{1}{2}-x, \bar{z}, \frac{1}{2}-y$ ;	$\frac{1}{2}-x, z, y+\frac{1}{2}$ ;	$x+\frac{1}{2}, z, \frac{1}{2}-y$ ;	$x+\frac{1}{2}, \bar{z}, y+\frac{1}{2}$ ;
$\frac{1}{2}-z, \bar{y}, \frac{1}{2}-x$ ;	$z+\frac{1}{2}, y, \frac{1}{2}-x$ ;	$z+\frac{1}{2}, \bar{y}, x+\frac{1}{2}$ ;	$\frac{1}{2}-z, y, x+\frac{1}{2}$ ;
$\frac{1}{2}-x, \bar{y}, \frac{1}{2}-z$ ;	$\frac{1}{2}-x, y, z+\frac{1}{2}$ ;	$x+\frac{1}{2}, \bar{y}, z+\frac{1}{2}$ ;	$x+\frac{1}{2}, y, \frac{1}{2}-z$ ;
$\frac{1}{2}-z, \bar{x}, \frac{1}{2}-y$ ;	$z+\frac{1}{2}, \bar{x}, y+\frac{1}{2}$ ;	$z+\frac{1}{2}, x, \frac{1}{2}-y$ ;	$\frac{1}{2}-z, x, y+\frac{1}{2}$ ;
$\frac{1}{2}-y, \bar{z}, \frac{1}{2}-x$ ;	$y+\frac{1}{2}, \bar{z}, \frac{1}{2}-x$ ;	$\frac{1}{2}-y, z, x+\frac{1}{2}$ ;	$y+\frac{1}{2}, \bar{z}, x+\frac{1}{2}$ ;
$y+\frac{1}{2}, x, z+\frac{1}{2}$ ;	$\frac{1}{2}-y, x, \frac{1}{2}-z$ ;	$y+\frac{1}{2}, \bar{x}, \frac{1}{2}-z$ ;	$\frac{1}{2}-y, \bar{x}, z+\frac{1}{2}$ ;
$x+\frac{1}{2}, z, y+\frac{1}{2}$ ;	$x+\frac{1}{2}, \bar{z}, \frac{1}{2}-y$ ;	$\frac{1}{2}-x, \bar{z}, y+\frac{1}{2}$ ;	$\frac{1}{2}-x, z, \frac{1}{2}-y$ ;
$z+\frac{1}{2}, y, x+\frac{1}{2}$ ;	$\frac{1}{2}-z, \bar{y}, x+\frac{1}{2}$ ;	$\frac{1}{2}-z, y, \frac{1}{2}-x$ ;	$\frac{1}{2}-z, \bar{y}, \frac{1}{2}-x$ ;
$x, y+\frac{1}{2}, z+\frac{1}{2}$ ;	$x, \frac{1}{2}-y, \frac{1}{2}-z$ ;	$\bar{x}, y+\frac{1}{2}, \frac{1}{2}-z$ ;	$\bar{x}, \frac{1}{2}-y, z+\frac{1}{2}$ ;
$z, x+\frac{1}{2}, y+\frac{1}{2}$ ;	$\bar{z}, x+\frac{1}{2}, \frac{1}{2}-y$ ;	$\bar{z}, \frac{1}{2}-x, y+\frac{1}{2}$ ;	$z, \frac{1}{2}-x, \frac{1}{2}-y$ ;
$y, z+\frac{1}{2}, x+\frac{1}{2}$ ;	$\bar{y}, \frac{1}{2}-z, x+\frac{1}{2}$ ;	$y, \frac{1}{2}-z, \frac{1}{2}-x$ ;	$\bar{y}, z+\frac{1}{2}, \frac{1}{2}-x$ ;
$\bar{y}, \frac{1}{2}-x, \frac{1}{2}-z$ ;	$y, \frac{1}{2}-x, z+\frac{1}{2}$ ;	$\bar{y}, x+\frac{1}{2}, z+\frac{1}{2}$ ;	$y, x+\frac{1}{2}, \frac{1}{2}-z$ ;
$\bar{x}, \frac{1}{2}-z, \frac{1}{2}-y$ ;	$\bar{x}, z+\frac{1}{2}, y+\frac{1}{2}$ ;	$x, z+\frac{1}{2}, \frac{1}{2}-y$ ;	$\bar{x}, \frac{1}{2}-z, y+\frac{1}{2}$ ;
$\bar{z}, \frac{1}{2}-y, \frac{1}{2}-x$ ;	$z, y+\frac{1}{2}, \frac{1}{2}-x$ ;	$z, \frac{1}{2}-y, x+\frac{1}{2}$ ;	$\bar{z}, y+\frac{1}{2}, x+\frac{1}{2}$ ;
$\bar{x}, \frac{1}{2}-y, \frac{1}{2}-z$ ;	$\bar{x}, y+\frac{1}{2}, z+\frac{1}{2}$ ;	$x, \frac{1}{2}-y, z+\frac{1}{2}$ ;	$\bar{x}, y+\frac{1}{2}, \frac{1}{2}-z$ ;
$\bar{z}, \frac{1}{2}-x, \frac{1}{2}-y$ ;	$z, \frac{1}{2}-x, y+\frac{1}{2}$ ;	$z, x+\frac{1}{2}, \frac{1}{2}-y$ ;	$\bar{z}, x+\frac{1}{2}, y+\frac{1}{2}$ ;
$\bar{y}, \frac{1}{2}-z, \frac{1}{2}-x$ ;	$y, z+\frac{1}{2}, \frac{1}{2}-x$ ;	$\bar{y}, z+\frac{1}{2}, x+\frac{1}{2}$ ;	$y, \frac{1}{2}-z, x+\frac{1}{2}$ ;
$y, x+\frac{1}{2}, z+\frac{1}{2}$ ;	$\bar{y}, x+\frac{1}{2}, \frac{1}{2}-z$ ;	$y, \frac{1}{2}-x, \frac{1}{2}-z$ ;	$\bar{y}, \frac{1}{2}-x, z+\frac{1}{2}$ ;
$x, z+\frac{1}{2}, y+\frac{1}{2}$ ;	$\bar{x}, \frac{1}{2}-z, \frac{1}{2}-y$ ;	$\bar{x}, \frac{1}{2}-z, y+\frac{1}{2}$ ;	$\bar{x}, z+\frac{1}{2}, \frac{1}{2}-y$ ;
$z, y+\frac{1}{2}, x+\frac{1}{2}$ ;	$\bar{z}, \frac{1}{2}-y, x+\frac{1}{2}$ ;	$\bar{z}, y+\frac{1}{2}, \frac{1}{2}-x$ ;	$z, \frac{1}{2}-y, \frac{1}{2}-x$ ;

SPACE-GROUP  $O_h^6$ .*Eight* equivalent positions:

(a) 8i. (b) 8e.

*Twenty-four* equivalent positions:

(c) 24c. (d) 24h.

SPACE-GROUP  $O_h^c$  (continued).

Forty-eight equivalent positions:

(e) 48a. (f) 48e.

Sixty-four equivalent positions:

(g) 64a.

Ninety-six equivalent positions:

(h) 96c. (i) 96d.

One hundred ninety-two equivalent positions:

- (j)  $xyz$ ;  $x\bar{y}\bar{z}$ ;  $\bar{x}y\bar{z}$ ;  $\bar{x}\bar{y}z$ ;  
 $zxy$ ;  $\bar{z}x\bar{y}$ ;  $\bar{z}\bar{x}y$ ;  $z\bar{x}\bar{y}$ ;  
 $yzx$ ;  $\bar{y}\bar{z}x$ ;  $y\bar{z}\bar{x}$ ;  $\bar{y}z\bar{x}$ ;  
 $\bar{y}\bar{z}\bar{x}$ ;  $y\bar{x}z$ ;  $\bar{y}xz$ ;  $yx\bar{z}$ ;  
 $\bar{x}\bar{z}y$ ;  $\bar{x}zy$ ;  $xz\bar{y}$ ;  $x\bar{z}y$ ;  
 $\bar{z}y\bar{x}$ ;  $zy\bar{x}$ ;  $z\bar{y}x$ ;  $\bar{z}yx$ ;  
 $\frac{1}{2}-x, \frac{1}{2}-y, \frac{1}{2}-z$ ;  $\frac{1}{2}-x, y+\frac{1}{2}, z+\frac{1}{2}$ ;  $x+\frac{1}{2}, \frac{1}{2}-y, z+\frac{1}{2}$ ;  
 $x+\frac{1}{2}, y+\frac{1}{2}, \frac{1}{2}-z$ ;  
 $\frac{1}{2}-z, \frac{1}{2}-x, \frac{1}{2}-y$ ;  $z+\frac{1}{2}, \frac{1}{2}-x, y+\frac{1}{2}$ ;  $z+\frac{1}{2}, x+\frac{1}{2}, \frac{1}{2}-y$ ;  
 $\frac{1}{2}-z, x+\frac{1}{2}, y+\frac{1}{2}$ ;  
 $\frac{1}{2}-y, \frac{1}{2}-z, \frac{1}{2}-x$ ;  $y+\frac{1}{2}, z+\frac{1}{2}, \frac{1}{2}-x$ ;  $\frac{1}{2}-y, z+\frac{1}{2}, x+\frac{1}{2}$ ;  
 $y+\frac{1}{2}, \frac{1}{2}-z, x+\frac{1}{2}$ ;  
 $y+\frac{1}{2}, x+\frac{1}{2}, z+\frac{1}{2}$ ;  $\frac{1}{2}-y, x+\frac{1}{2}, \frac{1}{2}-z$ ;  $y+\frac{1}{2}, \frac{1}{2}-x, \frac{1}{2}-z$ ;  
 $\frac{1}{2}-y, \frac{1}{2}-x, z+\frac{1}{2}$ ;  
 $x+\frac{1}{2}, z+\frac{1}{2}, y+\frac{1}{2}$ ;  $x+\frac{1}{2}, \frac{1}{2}-z, \frac{1}{2}-y$ ;  $\frac{1}{2}-x, \frac{1}{2}-z, y+\frac{1}{2}$ ;  
 $\frac{1}{2}-x, z+\frac{1}{2}, \frac{1}{2}-y$ ;  
 $z+\frac{1}{2}, y+\frac{1}{2}, x+\frac{1}{2}$ ;  $\frac{1}{2}-z, \frac{1}{2}-y, x+\frac{1}{2}$ ;  $\frac{1}{2}-z, y+\frac{1}{2}, \frac{1}{2}-x$ ;  
 $z+\frac{1}{2}, \frac{1}{2}-y, \frac{1}{2}-x$ ;  
 $x+\frac{1}{2}, y+\frac{1}{2}, z$ ;  $x+\frac{1}{2}, \frac{1}{2}-y, \bar{z}$ ;  $\frac{1}{2}-x, y+\frac{1}{2}, \bar{z}$ ;  $\frac{1}{2}-x, \frac{1}{2}-y, z$ ;  
 $z+\frac{1}{2}, x+\frac{1}{2}, y$ ;  $\frac{1}{2}-z, x+\frac{1}{2}, \bar{y}$ ;  $\frac{1}{2}-z, \frac{1}{2}-x, y$ ;  $z+\frac{1}{2}, \frac{1}{2}-x, \bar{y}$ ;  
 $y+\frac{1}{2}, z+\frac{1}{2}, x$ ;  $\frac{1}{2}-y, \frac{1}{2}-z, x$ ;  $y+\frac{1}{2}, \frac{1}{2}-z, \bar{x}$ ;  $\frac{1}{2}-y, z+\frac{1}{2}, \bar{x}$ ;  
 $\frac{1}{2}-y, \frac{1}{2}-x, \bar{z}$ ;  $y+\frac{1}{2}, \frac{1}{2}-x, z$ ;  $\frac{1}{2}-y, x+\frac{1}{2}, z$ ;  $y+\frac{1}{2}, x+\frac{1}{2}, \bar{z}$ ;  
 $\frac{1}{2}-x, \frac{1}{2}-z, \bar{y}$ ;  $\frac{1}{2}-x, z+\frac{1}{2}, y$ ;  $x+\frac{1}{2}, z+\frac{1}{2}, \bar{y}$ ;  $x+\frac{1}{2}, \frac{1}{2}-z, y$ ;  
 $\frac{1}{2}-z, \frac{1}{2}-y, \bar{x}$ ;  $z+\frac{1}{2}, y+\frac{1}{2}, \bar{x}$ ;  $z+\frac{1}{2}, \frac{1}{2}-y, x$ ;  $\frac{1}{2}-z, y+\frac{1}{2}, x$ ;  
 $\bar{x}, \bar{y}, \frac{1}{2}-z$ ;  $\bar{x}, y, z+\frac{1}{2}$ ;  $x, \bar{y}, z+\frac{1}{2}$ ;  $x, y, \frac{1}{2}-z$ ;  
 $\bar{z}, \bar{x}, \frac{1}{2}-y$ ;  $z, \bar{x}, y+\frac{1}{2}$ ;  $z, x, \frac{1}{2}-y$ ;  $\bar{z}, x, y+\frac{1}{2}$ ;  
 $\bar{y}, \bar{z}, \frac{1}{2}-x$ ;  $y, z, \frac{1}{2}-x$ ;  $\bar{y}, z, x+\frac{1}{2}$ ;  $y, \bar{z}, x+\frac{1}{2}$ ;  
 $y, x, z+\frac{1}{2}$ ;  $\bar{y}, x, \frac{1}{2}-z$ ;  $y, \bar{x}, \frac{1}{2}-z$ ;  $\bar{y}, x, z+\frac{1}{2}$ ;  
 $x, z, y+\frac{1}{2}$ ;  $x, \bar{z}, \frac{1}{2}-y$ ;  $\bar{x}, \bar{z}, y+\frac{1}{2}$ ;  $\bar{x}, z, \frac{1}{2}-y$ ;  
 $z, y, x+\frac{1}{2}$ ;  $\bar{z}, \bar{y}, x+\frac{1}{2}$ ;  $\bar{z}, y, \frac{1}{2}-x$ ;  $z, \bar{y}, \frac{1}{2}-x$ ;  
 $x+\frac{1}{2}, y, z+\frac{1}{2}$ ;  $x+\frac{1}{2}, \bar{y}, \frac{1}{2}-z$ ;  $\frac{1}{2}-x, y, \frac{1}{2}-z$ ;  $\frac{1}{2}-x, \bar{y}, z+\frac{1}{2}$ ;  
 $z+\frac{1}{2}, x, y+\frac{1}{2}$ ;  $\frac{1}{2}-z, x, \frac{1}{2}-y$ ;  $\frac{1}{2}-z, \bar{x}, y+\frac{1}{2}$ ;  $z+\frac{1}{2}, \bar{x}, \frac{1}{2}-y$ ;  
 $y+\frac{1}{2}, z, x+\frac{1}{2}$ ;  $\frac{1}{2}-y, \bar{z}, x+\frac{1}{2}$ ;  $y+\frac{1}{2}, \bar{z}, \frac{1}{2}-x$ ;  $\frac{1}{2}-y, z, \frac{1}{2}-x$ ;  
 $\frac{1}{2}-y, \bar{x}, \frac{1}{2}-z$ ;  $y+\frac{1}{2}, \bar{x}, z+\frac{1}{2}$ ;  $\frac{1}{2}-y, x, z+\frac{1}{2}$ ;  $y+\frac{1}{2}, x, \frac{1}{2}-z$ ;  
 $\frac{1}{2}-x, \bar{z}, \frac{1}{2}-y$ ;  $\frac{1}{2}-x, z, y+\frac{1}{2}$ ;  $x+\frac{1}{2}, z, \frac{1}{2}-y$ ;  $x+\frac{1}{2}, \bar{z}, y+\frac{1}{2}$ ;  
 $\frac{1}{2}-z, \bar{y}, \frac{1}{2}-x$ ;  $z+\frac{1}{2}, y, \frac{1}{2}-x$ ;  $z+\frac{1}{2}, \bar{y}, x+\frac{1}{2}$ ;  $\frac{1}{2}-z, y, x+\frac{1}{2}$ ;

SPACE-GROUP  $O_h^6$  (continued).

$\bar{x}, \frac{1}{2}-y, \bar{z};$	$\bar{x}, y+\frac{1}{2}, z;$	$x, \frac{1}{2}-y, z;$	$x, y+\frac{1}{2}, \bar{z};$
$\bar{z}, \frac{1}{2}-x, \bar{y};$	$z, \frac{1}{2}-x, y;$	$z, x+\frac{1}{2}, \bar{y};$	$\bar{z}, x+\frac{1}{2}, y;$
$\bar{y}, \frac{1}{2}-z, \bar{x};$	$y, z+\frac{1}{2}, \bar{x};$	$\bar{y}, z+\frac{1}{2}, x;$	$y, \frac{1}{2}-z, x;$
$y, x+\frac{1}{2}, z;$	$\bar{y}, x+\frac{1}{2}, \bar{z};$	$y, \frac{1}{2}-x, \bar{z};$	$\bar{y}, \frac{1}{2}-x, z;$
$x, z+\frac{1}{2}, y;$	$x, \frac{1}{2}-z, \bar{y};$	$\bar{x}, \frac{1}{2}-z, y;$	$\bar{x}, z+\frac{1}{2}, \bar{y};$
$z, y+\frac{1}{2}, x;$	$\bar{z}, \frac{1}{2}-y, x;$	$\bar{z}, y+\frac{1}{2}, \bar{x};$	$z, \frac{1}{2}-y, \bar{x};$
$x, y+\frac{1}{2}, z+\frac{1}{2};$	$x, \frac{1}{2}-y, \frac{1}{2}-z;$	$\bar{x}, y+\frac{1}{2}, \frac{1}{2}-z;$	$\bar{x}, \frac{1}{2}-y, z+\frac{1}{2};$
$z, x+\frac{1}{2}, y+\frac{1}{2};$	$\bar{z}, x+\frac{1}{2}, \frac{1}{2}-y;$	$\bar{z}, \frac{1}{2}-x, y+\frac{1}{2};$	$z, \frac{1}{2}-x, \frac{1}{2}-y;$
$y, z+\frac{1}{2}, x+\frac{1}{2};$	$\bar{y}, \frac{1}{2}-z, x+\frac{1}{2};$	$y, \frac{1}{2}-z, \frac{1}{2}-x;$	$\bar{y}, z+\frac{1}{2}, \frac{1}{2}-x;$
$\bar{y}, \frac{1}{2}-x, \frac{1}{2}-z;$	$y, \frac{1}{2}-x, z+\frac{1}{2};$	$\bar{y}, x+\frac{1}{2}, z+\frac{1}{2};$	$y, x+\frac{1}{2}, \frac{1}{2}-z;$
$\bar{x}, \frac{1}{2}-z, \frac{1}{2}-y;$	$\bar{x}, z+\frac{1}{2}, y+\frac{1}{2};$	$x, z+\frac{1}{2}, \frac{1}{2}-y;$	$x, \frac{1}{2}-z, y+\frac{1}{2};$
$\bar{z}, \frac{1}{2}-y, \frac{1}{2}-x;$	$z, y+\frac{1}{2}, \frac{1}{2}-x;$	$z, \frac{1}{2}-y, x+\frac{1}{2};$	$\bar{z}, y+\frac{1}{2}, x+\frac{1}{2};$
$\frac{1}{2}-x, \bar{y}, \bar{z};$	$\frac{1}{2}-x, y, z;$	$x+\frac{1}{2}, \bar{y}, z;$	$x+\frac{1}{2}, y, \bar{z};$
$\frac{1}{2}-z, \bar{x}, \bar{y};$	$z+\frac{1}{2}, \bar{x}, y;$	$z+\frac{1}{2}, x, \bar{y};$	$\frac{1}{2}-z, x, y;$
$\frac{1}{2}-y, \bar{z}, \bar{x};$	$y+\frac{1}{2}, z, \bar{x};$	$\frac{1}{2}-y, z, x;$	$y+\frac{1}{2}, \bar{z}, x;$
$y+\frac{1}{2}, x, z;$	$\frac{1}{2}-y, x, \bar{z};$	$y+\frac{1}{2}, \bar{x}, \bar{z};$	$\frac{1}{2}-y, \bar{x}, z;$
$x+\frac{1}{2}, z, y;$	$x+\frac{1}{2}, \bar{z}, \bar{y};$	$\frac{1}{2}-x, \bar{z}, y;$	$\frac{1}{2}-x, z, \bar{y};$
$z+\frac{1}{2}, y, x;$	$\frac{1}{2}-z, \bar{y}, x;$	$\frac{1}{2}-z, y, \bar{x};$	$z+\frac{1}{2}, \bar{y}, \bar{x};$

SPACE-GROUP  $O_h^7$ .

*Eight* equivalent positions:

(a) 8f.                      (b) 8g.

*Sixteen* equivalent positions:

(c) 16b.                      (d) 16c.

*Thirty-two* equivalent positions:

(e) 32b.

*Forty-eight* equivalent positions:

(f) 48c.

*Ninety-six* equivalent positions:

(g) 96e.                      (h) 96f.

*One hundred ninety-two* equivalent positions:

- (i)  $xyz; \quad x\bar{y}\bar{z}; \quad \bar{x}y\bar{z}; \quad \bar{x}\bar{y}z;$   
 $zxy; \quad \bar{z}x\bar{y}; \quad \bar{z}\bar{x}y; \quad z\bar{x}\bar{y};$   
 $yzx; \quad \bar{y}\bar{z}x; \quad y\bar{z}\bar{x}; \quad \bar{y}z\bar{x};$   
 $\frac{1}{2}-y, \frac{1}{2}-x, \frac{1}{2}-z; \quad y+\frac{1}{2}, \frac{1}{2}-x, z+\frac{1}{2}; \quad \frac{1}{2}-y, x+\frac{1}{2}, z+\frac{1}{2};$   
 $\quad \quad \quad y+\frac{1}{2}, x+\frac{1}{2}, \frac{1}{2}-z;$   
 $\frac{1}{2}-x, \frac{1}{2}-z, \frac{1}{2}-y; \quad \frac{1}{2}-x, z+\frac{1}{2}, y+\frac{1}{2}; \quad x+\frac{1}{2}, z+\frac{1}{2}, \frac{1}{2}-y;$   
 $\quad \quad \quad x+\frac{1}{2}, \frac{1}{2}-z, y+\frac{1}{2};$   
 $\frac{1}{2}-z, \frac{1}{2}-y, \frac{1}{2}-x; \quad z+\frac{1}{2}, y+\frac{1}{2}, \frac{1}{2}-x; \quad z+\frac{1}{2}, \frac{1}{2}-y, x+\frac{1}{2};$   
 $\quad \quad \quad \frac{1}{2}-z, y+\frac{1}{2}, x+\frac{1}{2};$   
 $\frac{1}{2}-x, \frac{1}{2}-y, \frac{1}{2}-z; \quad \frac{1}{2}-x, y+\frac{1}{2}, z+\frac{1}{2}; \quad x+\frac{1}{2}, \frac{1}{2}-y, z+\frac{1}{2};$   
 $\quad \quad \quad x+\frac{1}{2}, y+\frac{1}{2}, \frac{1}{2}-z;$

SPACE-GROUP  $O_h^7$  (continued).

$\frac{1}{2}-z, \frac{1}{2}-x, \frac{1}{2}-y; z+\frac{1}{2}, \frac{1}{2}-x, y+\frac{1}{2}; z+\frac{1}{2}, x+\frac{1}{2}, \frac{1}{2}-y;$   
 $\frac{1}{2}-z, x+\frac{1}{2}, y+\frac{1}{2};$   
 $\frac{1}{2}-y, \frac{1}{2}-z, \frac{1}{2}-x; y+\frac{1}{2}, z+\frac{1}{2}, \frac{1}{2}-x; \frac{1}{2}-y, z+\frac{1}{2}, x+\frac{1}{2};$   
 $y+\frac{1}{2}, \frac{1}{2}-z, x+\frac{1}{2};$   
 $yxz; \bar{y}x\bar{z}; y\bar{x}\bar{z}; \bar{y}\bar{x}z;$   
 $xzy; x\bar{z}\bar{y}; \bar{x}\bar{z}y; \bar{x}z\bar{y};$   
 $zyx; \bar{z}\bar{y}\bar{x}; \bar{z}y\bar{x}; z\bar{y}\bar{x};$   
 $x+\frac{1}{2}, y+\frac{1}{2}, z; x+\frac{1}{2}, \frac{1}{2}-y, \bar{z}; \frac{1}{2}-x, y+\frac{1}{2}, \bar{z}; \frac{1}{2}-x, \frac{1}{2}-y, z;$   
 $z+\frac{1}{2}, x+\frac{1}{2}, y; \frac{1}{2}-z, x+\frac{1}{2}, \bar{y}; \frac{1}{2}-z, \frac{1}{2}-x, y; z+\frac{1}{2}, \frac{1}{2}-x, \bar{y};$   
 $y+\frac{1}{2}, z+\frac{1}{2}, x; \frac{1}{2}-y, \frac{1}{2}-z, x; y+\frac{1}{2}, \frac{1}{2}-z, \bar{x}; \frac{1}{2}-y, z+\frac{1}{2}, \bar{x};$   
 $\frac{1}{2}-y, \frac{1}{2}-x, \frac{1}{2}-z; y+\frac{1}{2}, \frac{1}{2}-x, z+\frac{1}{2}; \frac{1}{2}-y, x+\frac{1}{2}, z+\frac{1}{2};$   
 $y+\frac{1}{2}, x+\frac{1}{2}, \frac{1}{2}-z;$   
 $\frac{1}{2}-x, \frac{1}{2}-z, \frac{1}{2}-y; \frac{1}{2}-x, z+\frac{1}{2}, y+\frac{1}{2}; x+\frac{1}{2}, z+\frac{1}{2}, \frac{1}{2}-y;$   
 $x+\frac{1}{2}, \frac{1}{2}-z, y+\frac{1}{2};$   
 $\frac{1}{2}-z, \frac{1}{2}-y, \frac{1}{2}-x; z+\frac{1}{2}, y+\frac{1}{2}, \frac{1}{2}-x; z+\frac{1}{2}, \frac{1}{2}-y, x+\frac{1}{2};$   
 $\frac{1}{2}-z, y+\frac{1}{2}, x+\frac{1}{2};$   
 $\frac{1}{2}-x, \frac{1}{2}-y, \frac{1}{2}-z; \frac{1}{2}-x, y+\frac{1}{2}, z+\frac{1}{2}; x+\frac{1}{2}, \frac{1}{2}-y, z+\frac{1}{2};$   
 $x+\frac{1}{2}, y+\frac{1}{2}, \frac{1}{2}-z;$   
 $\frac{1}{2}-z, \frac{1}{2}-x, \frac{1}{2}-y; z+\frac{1}{2}, \frac{1}{2}-x, y+\frac{1}{2}; z+\frac{1}{2}, x+\frac{1}{2}, \frac{1}{2}-y;$   
 $\frac{1}{2}-z, x+\frac{1}{2}, y+\frac{1}{2};$   
 $\frac{1}{2}-y, \frac{1}{2}-z, \frac{1}{2}-x; y+\frac{1}{2}, z+\frac{1}{2}, \frac{1}{2}-x; \frac{1}{2}-y, z+\frac{1}{2}, x+\frac{1}{2};$   
 $y+\frac{1}{2}, \frac{1}{2}-z, x+\frac{1}{2};$   
 $y+\frac{1}{2}, x+\frac{1}{2}, z; \frac{1}{2}-y, x+\frac{1}{2}, \bar{z}; y+\frac{1}{2}, \frac{1}{2}-x, \bar{z}; \frac{1}{2}-y, \frac{1}{2}-x, z;$   
 $x+\frac{1}{2}, z+\frac{1}{2}, y; x+\frac{1}{2}, \frac{1}{2}-z, \bar{y}; \frac{1}{2}-x, \frac{1}{2}-z, y; \frac{1}{2}-x, z+\frac{1}{2}, \bar{y};$   
 $z+\frac{1}{2}, y+\frac{1}{2}, x; \frac{1}{2}-z, \frac{1}{2}-y, x; \frac{1}{2}-z, y+\frac{1}{2}, \bar{x}; z+\frac{1}{2}, \frac{1}{2}-y, \bar{x};$   
 $x+\frac{1}{2}, y, z+\frac{1}{2}; x+\frac{1}{2}, \bar{y}, \frac{1}{2}-z; \frac{1}{2}-x, y, \frac{1}{2}-z; \frac{1}{2}-x, \bar{y}, z+\frac{1}{2};$   
 $z+\frac{1}{2}, x, y+\frac{1}{2}; \frac{1}{2}-z, x, \frac{1}{2}-y; \frac{1}{2}-z, \bar{x}, y+\frac{1}{2}; z+\frac{1}{2}, \bar{x}, \frac{1}{2}-y;$   
 $y+\frac{1}{2}, z, x+\frac{1}{2}; \frac{1}{2}-y, \bar{z}, x+\frac{1}{2}; y+\frac{1}{2}, \bar{z}, \frac{1}{2}-x; \frac{1}{2}-y, z, \frac{1}{2}-x;$   
 $\frac{1}{2}-y, \frac{1}{2}-x, \frac{1}{2}-z; y+\frac{1}{2}, \frac{1}{2}-x, z+\frac{1}{2}; \frac{1}{2}-y, x+\frac{1}{2}, z+\frac{1}{2};$   
 $y+\frac{1}{2}, x+\frac{1}{2}, \frac{1}{2}-z;$   
 $\frac{1}{2}-x, \frac{1}{2}-z, \frac{1}{2}-y; \frac{1}{2}-x, z+\frac{1}{2}, y+\frac{1}{2}; x+\frac{1}{2}, z+\frac{1}{2}, \frac{1}{2}-y;$   
 $x+\frac{1}{2}, \frac{1}{2}-z, y+\frac{1}{2};$   
 $\frac{1}{2}-z, \frac{1}{2}-y, \frac{1}{2}-x; z+\frac{1}{2}, y+\frac{1}{2}, \frac{1}{2}-x; z+\frac{1}{2}, \frac{1}{2}-y, x+\frac{1}{2};$   
 $\frac{1}{2}-z, y+\frac{1}{2}, x+\frac{1}{2};$   
 $\frac{1}{2}-x, \frac{1}{2}-y, \frac{1}{2}-z; \frac{1}{2}-x, y+\frac{1}{2}, z+\frac{1}{2}; x+\frac{1}{2}, \frac{1}{2}-y, z+\frac{1}{2};$   
 $x+\frac{1}{2}, y+\frac{1}{2}, \frac{1}{2}-z;$   
 $\frac{1}{2}-z, \frac{1}{2}-x, \frac{1}{2}-y; z+\frac{1}{2}, \frac{1}{2}-x, y+\frac{1}{2}; z+\frac{1}{2}, x+\frac{1}{2}, \frac{1}{2}-y;$   
 $\frac{1}{2}-z, x+\frac{1}{2}, y+\frac{1}{2};$   
 $\frac{1}{2}-y, \frac{1}{2}-z, \frac{1}{2}-x; y+\frac{1}{2}, z+\frac{1}{2}, \frac{1}{2}-x; \frac{1}{2}-y, z+\frac{1}{2}, x+\frac{1}{2};$   
 $y+\frac{1}{2}, \frac{1}{2}-z, x+\frac{1}{2};$   
 $y+\frac{1}{2}, x, z+\frac{1}{2}; \frac{1}{2}-y, x, \frac{1}{2}-z; y+\frac{1}{2}, \bar{x}, \frac{1}{2}-z; \frac{1}{2}-y, \bar{x}, z+\frac{1}{2};$   
 $x+\frac{1}{2}, z, y+\frac{1}{2}; x+\frac{1}{2}, \bar{z}, \frac{1}{2}-y; \frac{1}{2}-x, \bar{z}, y+\frac{1}{2}; \frac{1}{2}-x, z, \frac{1}{2}-y;$   
 $z+\frac{1}{2}, y, x+\frac{1}{2}; \frac{1}{2}-z, \bar{y}, x+\frac{1}{2}; \frac{1}{2}-z, y, \frac{1}{2}-x; z+\frac{1}{2}, \bar{y}, \frac{1}{2}-x;$   
 $x, y+\frac{1}{2}, z+\frac{1}{2}; x, \frac{1}{2}-y, \frac{1}{2}-z; \bar{x}, y+\frac{1}{2}, \frac{1}{2}-z; \bar{x}, \frac{1}{2}-y, z+\frac{1}{2};$   
 $z, x+\frac{1}{2}, y+\frac{1}{2}; \bar{z}, x+\frac{1}{2}, \frac{1}{2}-y; \bar{z}, \frac{1}{2}-x, y+\frac{1}{2}; z, \frac{1}{2}-x, \frac{1}{2}-y;$



SPACE-GROUP  $O_h^7$  (continued).

$y, z+\frac{1}{2}, x+\frac{1}{2}; \bar{y}, \frac{1}{2}-z, x+\frac{1}{2}; y, \frac{1}{2}-z, \frac{1}{2}-x; \bar{y}, z+\frac{1}{2}, \frac{1}{2}-x;$   
 $\frac{1}{2}-y, \frac{1}{2}-x, \frac{1}{2}-z; y+\frac{1}{2}, \frac{1}{2}-x, z+\frac{1}{2}; \frac{1}{2}-y, x+\frac{1}{2}, z+\frac{1}{2};$   
 $y+\frac{1}{2}, x+\frac{1}{2}, \frac{1}{2}-z;$   
 $\frac{1}{2}-x, \frac{1}{2}-z, \frac{1}{2}-y; \frac{1}{2}-x, z+\frac{1}{2}, y+\frac{1}{2}; x+\frac{1}{2}, z+\frac{1}{2}, \frac{1}{2}-y;$   
 $x+\frac{1}{2}, \frac{1}{2}-z, y+\frac{1}{2};$   
 $\frac{1}{2}-z, \frac{1}{2}-y, \frac{1}{2}-x; z+\frac{1}{2}, y+\frac{1}{2}, \frac{1}{2}-x; z+\frac{1}{2}, \frac{1}{2}-y, x+\frac{1}{2};$   
 $\frac{1}{2}-z, y+\frac{1}{2}, x+\frac{1}{2};$   
 $\frac{1}{2}-x, \frac{1}{2}-y, \frac{1}{2}-z; \frac{1}{2}-x, y+\frac{1}{2}, z+\frac{1}{2}; x+\frac{1}{2}, \frac{1}{2}-y, z+\frac{1}{2};$   
 $x+\frac{1}{2}, y+\frac{1}{2}, \frac{1}{2}-z;$   
 $\frac{1}{2}-z, \frac{1}{2}-x, \frac{1}{2}-y; z+\frac{1}{2}, \frac{1}{2}-x, y+\frac{1}{2}; z+\frac{1}{2}, x+\frac{1}{2}, \frac{1}{2}-y;$   
 $\frac{1}{2}-z, x+\frac{1}{2}, y+\frac{1}{2};$   
 $\frac{1}{2}-y, \frac{1}{2}-z, \frac{1}{2}-x; y+\frac{1}{2}, z+\frac{1}{2}, \frac{1}{2}-x; \frac{1}{2}-y, z+\frac{1}{2}, x+\frac{1}{2};$   
 $y+\frac{1}{2}, \frac{1}{2}-z, x+\frac{1}{2};$   
 $y, x+\frac{1}{2}, z+\frac{1}{2}; \bar{y}, x+\frac{1}{2}, \frac{1}{2}-z; y, \frac{1}{2}-x, \frac{1}{2}-z; \bar{y}, \frac{1}{2}-x, z+\frac{1}{2};$   
 $x, z+\frac{1}{2}, y+\frac{1}{2}; x, \frac{1}{2}-z, \frac{1}{2}-y; \bar{x}, \frac{1}{2}-z, y+\frac{1}{2}; \bar{x}, z+\frac{1}{2}, \frac{1}{2}-y;$   
 $z, y+\frac{1}{2}, x+\frac{1}{2}; \bar{z}, \frac{1}{2}-y, x+\frac{1}{2}; \bar{z}, y+\frac{1}{2}, \frac{1}{2}-x; z, \frac{1}{2}-y, \frac{1}{2}-x.$

SPACE-GROUP  $O_h^8$ .

Sixteen equivalent positions:

(a) 16h.

Thirty-two equivalent positions:

(b) 32d. (c) 32e.

Forty-eight equivalent positions:

(d) 48i.

Sixty-four equivalent positions:

(e) 64b.

Ninety-six equivalent positions:

(f) 96g. (g) 96h.

One hundred ninety-two equivalent positions:

(h)  $xyz; x\bar{y}\bar{z}; \bar{x}y\bar{z}; \bar{x}\bar{y}z;$   
 $zxy; \bar{z}\bar{x}\bar{y}; \bar{z}\bar{x}y; z\bar{x}\bar{y};$   
 $yzx; \bar{y}\bar{z}x; y\bar{z}\bar{x}; \bar{y}z\bar{x};$   
 $\frac{1}{2}-y, \frac{1}{2}-x, \frac{1}{2}-z; y+\frac{1}{2}, \frac{1}{2}-x, z+\frac{1}{2}; \frac{1}{2}-y, x+\frac{1}{2}, z+\frac{1}{2};$   
 $y+\frac{1}{2}, x+\frac{1}{2}, \frac{1}{2}-z;$   
 $\frac{1}{2}-x, \frac{1}{2}-z, \frac{1}{2}-y; \frac{1}{2}-x, z+\frac{1}{2}, y+\frac{1}{2}; x+\frac{1}{2}, z+\frac{1}{2}, \frac{1}{2}-y;$   
 $x+\frac{1}{2}, \frac{1}{2}-z, y+\frac{1}{2};$   
 $\frac{1}{2}-z, \frac{1}{2}-y, \frac{1}{2}-x; z+\frac{1}{2}, y+\frac{1}{2}, \frac{1}{2}-x; z+\frac{1}{2}, \frac{1}{2}-y, x+\frac{1}{2};$   
 $\frac{1}{2}-z, y+\frac{1}{2}, x+\frac{1}{2};$   
 $\frac{1}{2}-x, \frac{1}{2}-y, \frac{1}{2}-z; \frac{1}{2}-x, y+\frac{1}{2}, z+\frac{1}{2}; x+\frac{1}{2}, \frac{1}{2}-y, z+\frac{1}{2};$   
 $x+\frac{1}{2}, y+\frac{1}{2}, \frac{1}{2}-z;$   
 $\frac{1}{2}-z, \frac{1}{2}-x, \frac{1}{2}-y; z+\frac{1}{2}, \frac{1}{2}-x, y+\frac{1}{2}; z+\frac{1}{2}, x+\frac{1}{2}, \frac{1}{2}-y;$   
 $\frac{1}{2}-z, x+\frac{1}{2}, y+\frac{1}{2};$

SPACE-GROUP  $O_h^2$  (continued).

$\frac{1}{2}-y, \frac{1}{2}-z, \frac{1}{2}-x; y+\frac{1}{2}, z+\frac{1}{2}, \frac{1}{2}-x; \frac{1}{2}-y, z+\frac{1}{2}, x+\frac{1}{2};$   
 $y+\frac{1}{2}, \frac{1}{2}-z, x+\frac{1}{2};$   
 $y+\frac{1}{2}, x+\frac{1}{2}, z+\frac{1}{2}; \frac{1}{2}-y, x+\frac{1}{2}, \frac{1}{2}-z; y+\frac{1}{2}, \frac{1}{2}-x, \frac{1}{2}-z;$   
 $\frac{1}{2}-y, \frac{1}{2}-x, z+\frac{1}{2};$   
 $x+\frac{1}{2}, z+\frac{1}{2}, y+\frac{1}{2}; x+\frac{1}{2}, \frac{1}{2}-z, \frac{1}{2}-y; \frac{1}{2}-x, \frac{1}{2}-z, y+\frac{1}{2};$   
 $\frac{1}{2}-x, z+\frac{1}{2}, \frac{1}{2}-y;$   
 $z+\frac{1}{2}, y+\frac{1}{2}, x+\frac{1}{2}; \frac{1}{2}-z, \frac{1}{2}-y, x+\frac{1}{2}; \frac{1}{2}-z, y+\frac{1}{2}, \frac{1}{2}-x;$   
 $z+\frac{1}{2}, \frac{1}{2}-y, \frac{1}{2}-x;$   
 $x+\frac{1}{2}, y+\frac{1}{2}, z; x+\frac{1}{2}, \frac{1}{2}-y, \bar{z}; \frac{1}{2}-x, y+\frac{1}{2}, \bar{z}; \frac{1}{2}-x, \frac{1}{2}-y, z;$   
 $z+\frac{1}{2}, x+\frac{1}{2}, y; \frac{1}{2}-z, x+\frac{1}{2}, \bar{y}; \frac{1}{2}-z, \frac{1}{2}-x, y; z+\frac{1}{2}, \frac{1}{2}-x, \bar{y};$   
 $y+\frac{1}{2}, z+\frac{1}{2}, x; \frac{1}{2}-y, \frac{1}{2}-z, x; y+\frac{1}{2}, \frac{1}{2}-z, \bar{x}; \frac{1}{2}-y, z+\frac{1}{2}, \bar{x};$   
 $\frac{1}{2}-y, \frac{1}{2}-x, \frac{1}{2}-z; y+\frac{1}{2}, \frac{1}{2}-x, z+\frac{1}{2}; \frac{1}{2}-y, x+\frac{1}{2}, z+\frac{1}{2};$   
 $y+\frac{1}{2}, x+\frac{1}{2}, \frac{1}{2}-z;$   
 $\frac{1}{2}-x, \frac{1}{2}-z, \frac{1}{2}-y; \frac{1}{2}-x, z+\frac{1}{2}, y+\frac{1}{2}; x+\frac{1}{2}, z+\frac{1}{2}, \frac{1}{2}-y;$   
 $x+\frac{1}{2}, \frac{1}{2}-z, y+\frac{1}{2};$   
 $\frac{1}{2}-z, \frac{1}{2}-y, \frac{1}{2}-x; z+\frac{1}{2}, y+\frac{1}{2}, \frac{1}{2}-x; z+\frac{1}{2}, \frac{1}{2}-y, x+\frac{1}{2};$   
 $\frac{1}{2}-z, y+\frac{1}{2}, x+\frac{1}{2};$   
 $\frac{1}{2}-x, \frac{1}{2}-y, \frac{1}{2}-z; \frac{1}{2}-x, y+\frac{1}{2}, z+\frac{1}{2}; x+\frac{1}{2}, \frac{1}{2}-y, z+\frac{1}{2};$   
 $x+\frac{1}{2}, y+\frac{1}{2}, \frac{1}{2}-z;$   
 $\frac{1}{2}-z, \frac{1}{2}-x, \frac{1}{2}-y; z+\frac{1}{2}, \frac{1}{2}-x, y+\frac{1}{2}; z+\frac{1}{2}, x+\frac{1}{2}, \frac{1}{2}-y;$   
 $\frac{1}{2}-z, x+\frac{1}{2}, y+\frac{1}{2};$   
 $\frac{1}{2}-y, \frac{1}{2}-z, \frac{1}{2}-x; y+\frac{1}{2}, z+\frac{1}{2}, \frac{1}{2}-x; \frac{1}{2}-y, z+\frac{1}{2}, x+\frac{1}{2};$   
 $y+\frac{1}{2}, \frac{1}{2}-z, x+\frac{1}{2};$   
 $y, x, z+\frac{1}{2}; \bar{y}, x, \frac{1}{2}-z; y, \bar{x}, \frac{1}{2}-z; \bar{y}, \bar{x}, z+\frac{1}{2};$   
 $x, z, y+\frac{1}{2}; x, \bar{z}, \frac{1}{2}-y; \bar{x}, \bar{z}, y+\frac{1}{2}; \bar{x}, z, \frac{1}{2}-y;$   
 $z, y, x+\frac{1}{2}; \bar{z}, \bar{y}, x+\frac{1}{2}; \bar{z}, y, \frac{1}{2}-x; z, \bar{y}, \frac{1}{2}-x;$   
 $x+\frac{1}{2}, y, z+\frac{1}{2}; x+\frac{1}{2}, \bar{y}, \frac{1}{2}-z; \frac{1}{2}-x, y, \frac{1}{2}-z; \frac{1}{2}-x, \bar{y}, z+\frac{1}{2};$   
 $z+\frac{1}{2}, x, y+\frac{1}{2}; \frac{1}{2}-z, x, \frac{1}{2}-y; \frac{1}{2}-z, \bar{x}, y+\frac{1}{2}; z+\frac{1}{2}, \bar{x}, \frac{1}{2}-y;$   
 $y+\frac{1}{2}, z, x+\frac{1}{2}; \frac{1}{2}-y, \bar{z}, x+\frac{1}{2}; y+\frac{1}{2}, \bar{z}, \frac{1}{2}-x; \frac{1}{2}-y, z, \frac{1}{2}-x;$   
 $\frac{1}{2}-y, \frac{1}{2}-x, \frac{1}{2}-z; y+\frac{1}{2}, \frac{1}{2}-x, z+\frac{1}{2}; \frac{1}{2}-y, x+\frac{1}{2}, z+\frac{1}{2};$   
 $y+\frac{1}{2}, x+\frac{1}{2}, \frac{1}{2}-z;$   
 $\frac{1}{2}-x, \frac{1}{2}-z, \frac{1}{2}-y; \frac{1}{2}-x, z+\frac{1}{2}, y+\frac{1}{2}; x+\frac{1}{2}, z+\frac{1}{2}, \frac{1}{2}-y;$   
 $x+\frac{1}{2}, \frac{1}{2}-z, y+\frac{1}{2};$   
 $\frac{1}{2}-z, \frac{1}{2}-y, \frac{1}{2}-x; z+\frac{1}{2}, y+\frac{1}{2}, \frac{1}{2}-x; z+\frac{1}{2}, \frac{1}{2}-y, x+\frac{1}{2};$   
 $\frac{1}{2}-z, y+\frac{1}{2}, x+\frac{1}{2};$   
 $\frac{1}{2}-x, \frac{1}{2}-y, \frac{1}{2}-z; \frac{1}{2}-x, y+\frac{1}{2}, z+\frac{1}{2}; x+\frac{1}{2}, \frac{1}{2}-y, z+\frac{1}{2};$   
 $x+\frac{1}{2}, y+\frac{1}{2}, \frac{1}{2}-z;$   
 $\frac{1}{2}-z, \frac{1}{2}-x, \frac{1}{2}-y; z+\frac{1}{2}, \frac{1}{2}-x, y+\frac{1}{2}; z+\frac{1}{2}, x+\frac{1}{2}, \frac{1}{2}-y;$   
 $\frac{1}{2}-z, x+\frac{1}{2}, y+\frac{1}{2};$   
 $\frac{1}{2}-y, \frac{1}{2}-z, \frac{1}{2}-x; y+\frac{1}{2}, z+\frac{1}{2}, \frac{1}{2}-x; \frac{1}{2}-y, z+\frac{1}{2}, x+\frac{1}{2};$   
 $y+\frac{1}{2}, \frac{1}{2}-z, x+\frac{1}{2};$   
 $y, x+\frac{1}{2}, z; \bar{y}, x+\frac{1}{2}, \bar{z}; y, \frac{1}{2}-x, \bar{z}; \bar{y}, \frac{1}{2}-x, z;$   
 $x, z+\frac{1}{2}, y; x, \frac{1}{2}-z, \bar{y}; \bar{x}, \frac{1}{2}-z, y; \bar{x}, z+\frac{1}{2}, \bar{y};$   
 $z, y+\frac{1}{2}, x; \bar{z}, \frac{1}{2}-y, x; \bar{z}, y+\frac{1}{2}, \bar{x}; z, \frac{1}{2}-y, \bar{x};$   
 $x, y+\frac{1}{2}, z+\frac{1}{2}; x, \frac{1}{2}-y, \frac{1}{2}-z; \bar{x}, y+\frac{1}{2}, \frac{1}{2}-z; \bar{x}, \frac{1}{2}-y, z+\frac{1}{2};$

SPACE-GROUP  $O_h^6$  (continued).

$z, x+\frac{1}{2}, y+\frac{1}{2}; \bar{z}, x+\frac{1}{2}, \frac{1}{2}-y; \bar{z}, \frac{1}{2}-x, y+\frac{1}{2}; z, \frac{1}{2}-x, \frac{1}{2}-y;$   
 $y, z+\frac{1}{2}, x+\frac{1}{2}; \bar{y}, \frac{1}{2}-z, x+\frac{1}{2}; y, \frac{1}{2}-z, \frac{1}{2}-x; \bar{y}, z+\frac{1}{2}, \frac{1}{2}-x;$   
 $\frac{1}{2}-y, \frac{1}{2}-x, \frac{1}{2}-z; y+\frac{1}{2}, \frac{1}{2}-x, z+\frac{1}{2}; \frac{1}{2}-y, x+\frac{1}{2}, z+\frac{1}{2};$   
 $y+\frac{1}{2}, x+\frac{1}{2}, \frac{1}{2}-z;$   
 $\frac{1}{2}-x, \frac{1}{2}-z, \frac{1}{2}-y; \frac{1}{2}-x, z+\frac{1}{2}, y+\frac{1}{2}; x+\frac{1}{2}, z+\frac{1}{2}, \frac{1}{2}-y;$   
 $x+\frac{1}{2}, \frac{1}{2}-z, y+\frac{1}{2};$   
 $\frac{1}{2}-z, \frac{1}{2}-y, \frac{1}{2}-x; z+\frac{1}{2}, y+\frac{1}{2}, \frac{1}{2}-x; z+\frac{1}{2}, \frac{1}{2}-y, x+\frac{1}{2};$   
 $\frac{1}{2}-z, y+\frac{1}{2}, x+\frac{1}{2};$   
 $\frac{1}{2}-x, \frac{1}{2}-y, \frac{1}{2}-z; \frac{1}{2}-x, y+\frac{1}{2}, z+\frac{1}{2}; x+\frac{1}{2}, \frac{1}{2}-y, z+\frac{1}{2};$   
 $x+\frac{1}{2}, y+\frac{1}{2}, \frac{1}{2}-z;$   
 $\frac{1}{2}-z, \frac{1}{2}-x, \frac{1}{2}-y; z+\frac{1}{2}, \frac{1}{2}-x, y+\frac{1}{2}; z+\frac{1}{2}, x+\frac{1}{2}, \frac{1}{2}-y;$   
 $\frac{1}{2}-z, x+\frac{1}{2}, y+\frac{1}{2};$   
 $\frac{1}{2}-y, \frac{1}{2}-z, \frac{1}{2}-x; y+\frac{1}{2}, z+\frac{1}{2}, \frac{1}{2}-x; \frac{1}{2}-y, z+\frac{1}{2}, x+\frac{1}{2};$   
 $y+\frac{1}{2}, \frac{1}{2}-z, x+\frac{1}{2};$   
 $y+\frac{1}{2}, x, z; \frac{1}{2}-y, x, \bar{z}; y+\frac{1}{2}, \bar{x}, \bar{z}; \frac{1}{2}-y, \bar{x}, z;$   
 $x+\frac{1}{2}, z, y; x+\frac{1}{2}, \bar{z}, \bar{y}; \frac{1}{2}-x, \bar{z}, y; \frac{1}{2}-x, z, \bar{y};$   
 $z+\frac{1}{2}, y, x; \frac{1}{2}-z, \bar{y}, x; \frac{1}{2}-z, y, \bar{x}; z+\frac{1}{2}, \bar{y}, \bar{x}.$

SPACE-GROUP  $O_h^8$ .

*Two* equivalent positions:

(a) 2a.

*Six* equivalent positions:

(b) 6e.

*Eight* equivalent positions:

(c) 8e.

*Twelve* equivalent positions:

(d) 12h. (e) 12a.

*Sixteen* equivalent positions:

(f) 16d.

*Twenty-four* equivalent positions:

(g) 24f. (h) 24j.

*Forty-eight* equivalent positions:

(i) 48l. (j) 48j. (k) 48k.

*Ninety-six* equivalent positions:

(l)  $xyz; x\bar{y}\bar{z}; \bar{x}y\bar{z}; \bar{x}\bar{y}z;$   
 $zxy; \bar{z}x\bar{y}; \bar{z}\bar{x}y; z\bar{x}\bar{y};$   
 $yzx; \bar{y}\bar{z}x; y\bar{z}\bar{x}; \bar{y}z\bar{x};$   
 $\bar{y}\bar{z}\bar{x}; y\bar{x}z; \bar{y}xz; yx\bar{z};$   
 $\bar{x}\bar{z}\bar{y}; \bar{x}zy; xz\bar{y}; x\bar{z}y;$

SPACE-GROUP  $O_h^9$  (continued).

$\bar{x}\bar{y}\bar{x}$ ;  $zy\bar{x}$ ;  $z\bar{y}x$ ;  $\bar{x}yx$ ;  
 $\bar{x}\bar{y}\bar{z}$ ;  $\bar{x}yz$ ;  $x\bar{y}z$ ;  $xy\bar{z}$ ;  
 $\bar{x}\bar{x}\bar{y}$ ;  $\bar{x}\bar{x}y$ ;  $\bar{x}x\bar{y}$ ;  $\bar{x}xy$ ;  
 $\bar{y}\bar{x}\bar{x}$ ;  $y\bar{x}\bar{x}$ ;  $\bar{y}x\bar{x}$ ;  $y\bar{x}x$ ;  
 $yx\bar{z}$ ;  $\bar{y}x\bar{z}$ ;  $y\bar{x}\bar{z}$ ;  $\bar{y}\bar{x}z$ ;  
 $xzy$ ;  $x\bar{z}\bar{y}$ ;  $\bar{x}\bar{z}y$ ;  $\bar{x}z\bar{y}$ ;  
 $zyx$ ;  $\bar{z}\bar{y}x$ ;  $\bar{z}y\bar{x}$ ;  $z\bar{y}\bar{x}$ ;  
 $x+\frac{1}{2}, y+\frac{1}{2}, z+\frac{1}{2}$ ;  $x+\frac{1}{2}, \frac{1}{2}-y, \frac{1}{2}-z$ ;  $\frac{1}{2}-x, y+\frac{1}{2}, \frac{1}{2}-z$ ;  
 $\frac{1}{2}-x, \frac{1}{2}-y, z+\frac{1}{2}$ ;  
 $z+\frac{1}{2}, x+\frac{1}{2}, y+\frac{1}{2}$ ;  $\frac{1}{2}-z, x+\frac{1}{2}, \frac{1}{2}-y$ ;  $\frac{1}{2}-z, \frac{1}{2}-x, y+\frac{1}{2}$ ;  
 $z+\frac{1}{2}, \frac{1}{2}-x, \frac{1}{2}-y$ ;  
 $y+\frac{1}{2}, z+\frac{1}{2}, x+\frac{1}{2}$ ;  $\frac{1}{2}-y, \frac{1}{2}-z, x+\frac{1}{2}$ ;  $y+\frac{1}{2}, \frac{1}{2}-z, \frac{1}{2}-x$ ;  
 $\frac{1}{2}-y, z+\frac{1}{2}, \frac{1}{2}-x$ ;  
 $\frac{1}{2}-y, \frac{1}{2}-x, \frac{1}{2}-z$ ;  $y+\frac{1}{2}, \frac{1}{2}-x, z+\frac{1}{2}$ ;  $\frac{1}{2}-y, x+\frac{1}{2}, z+\frac{1}{2}$ ;  
 $y+\frac{1}{2}, x+\frac{1}{2}, \frac{1}{2}-z$ ;  
 $\frac{1}{2}-x, \frac{1}{2}-z, \frac{1}{2}-y$ ;  $\frac{1}{2}-x, z+\frac{1}{2}, y+\frac{1}{2}$ ;  $x+\frac{1}{2}, z+\frac{1}{2}, \frac{1}{2}-y$ ;  
 $x+\frac{1}{2}, \frac{1}{2}-z, y+\frac{1}{2}$ ;  
 $\frac{1}{2}-z, \frac{1}{2}-y, \frac{1}{2}-x$ ;  $z+\frac{1}{2}, y+\frac{1}{2}, \frac{1}{2}-x$ ;  $z+\frac{1}{2}, \frac{1}{2}-y, x+\frac{1}{2}$ ;  
 $\frac{1}{2}-z, y+\frac{1}{2}, x+\frac{1}{2}$ ;  
 $\frac{1}{2}-x, \frac{1}{2}-y, \frac{1}{2}-z$ ;  $\frac{1}{2}-x, y+\frac{1}{2}, z+\frac{1}{2}$ ;  $x+\frac{1}{2}, \frac{1}{2}-y, z+\frac{1}{2}$ ;  
 $x+\frac{1}{2}, y+\frac{1}{2}, \frac{1}{2}-z$ ;  
 $\frac{1}{2}-z, \frac{1}{2}-x, \frac{1}{2}-y$ ;  $z+\frac{1}{2}, \frac{1}{2}-x, y+\frac{1}{2}$ ;  $z+\frac{1}{2}, x+\frac{1}{2}, \frac{1}{2}-y$ ;  
 $\frac{1}{2}-z, x+\frac{1}{2}, y+\frac{1}{2}$ ;  
 $\frac{1}{2}-y, \frac{1}{2}-z, \frac{1}{2}-x$ ;  $y+\frac{1}{2}, z+\frac{1}{2}, \frac{1}{2}-x$ ;  $\frac{1}{2}-y, z+\frac{1}{2}, x+\frac{1}{2}$ ;  
 $y+\frac{1}{2}, \frac{1}{2}-z, x+\frac{1}{2}$ ;  
 $y+\frac{1}{2}, x+\frac{1}{2}, z+\frac{1}{2}$ ;  $\frac{1}{2}-y, x+\frac{1}{2}, \frac{1}{2}-z$ ;  $y+\frac{1}{2}, \frac{1}{2}-x, \frac{1}{2}-z$ ;  
 $\frac{1}{2}-y, \frac{1}{2}-x, z+\frac{1}{2}$ ;  
 $x+\frac{1}{2}, z+\frac{1}{2}, y+\frac{1}{2}$ ;  $x+\frac{1}{2}, \frac{1}{2}-z, \frac{1}{2}-y$ ;  $\frac{1}{2}-x, \frac{1}{2}-z, y+\frac{1}{2}$ ;  
 $\frac{1}{2}-x, z+\frac{1}{2}, \frac{1}{2}-y$ ;  
 $z+\frac{1}{2}, y+\frac{1}{2}, x+\frac{1}{2}$ ;  $\frac{1}{2}-z, \frac{1}{2}-y, x+\frac{1}{2}$ ;  $\frac{1}{2}-z, y+\frac{1}{2}, \frac{1}{2}-x$ ;  
 $z+\frac{1}{2}, \frac{1}{2}-y, \frac{1}{2}-x$ .

SPACE-GROUP  $O_h^{10}$ .

Sixteen equivalent positions:

- (a) 16h. (b) 16i.

Twenty-four equivalent positions:

- (c) 24v. (d) 24w.

Thirty-two equivalent positions:

- (e) 32f.

Forty-eight equivalent positions:

- (f) 48m. (g) 48n.

SPACE-GROUP  $O_h^{10}$  (continued).

Ninety-six equivalent positions:

- (h)  $xyz$ ;  $x, \bar{y}, \frac{1}{2}-z$ ;  $\frac{1}{2}-x, y, \bar{z}$ ;  $\bar{x}, \frac{1}{2}-y, z$ ;  
 $xy\bar{z}$ ;  $\frac{1}{2}-z, x, \bar{y}$ ;  $\bar{z}, \frac{1}{2}-x, y$ ;  $z, \bar{x}, \frac{1}{2}-y$ ;  
 $y\bar{x}z$ ;  $\bar{y}, \frac{1}{2}-z, x$ ;  $y, \bar{z}, \frac{1}{2}-x$ ;  $\frac{1}{2}-y, z, \bar{x}$ ;  
 $\frac{1}{2}-y, \frac{1}{2}-x, \frac{1}{2}-z$ ;  $y+\frac{1}{2}, \frac{1}{2}-x, z+\frac{1}{2}$ ;  $\frac{1}{2}-y, x+\frac{1}{2}, z+\frac{1}{2}$ ;  
 $y+\frac{1}{2}, x+\frac{1}{2}, \frac{1}{2}-z$ ;  
 $\frac{1}{2}-x, \frac{1}{2}-z, \frac{1}{2}-y$ ;  $\frac{1}{2}-x, z+\frac{1}{2}, y+\frac{1}{2}$ ;  $x+\frac{1}{2}, z+\frac{1}{2}, \frac{1}{2}-y$ ;  
 $x+\frac{1}{2}, \frac{1}{2}-z, y+\frac{1}{2}$ ;  
 $\frac{1}{2}-z, \frac{1}{2}-y, \frac{1}{2}-x$ ;  $z+\frac{1}{2}, y+\frac{1}{2}, \frac{1}{2}-x$ ;  $z+\frac{1}{2}, \frac{1}{2}-y, x+\frac{1}{2}$ ;  
 $\frac{1}{2}-z, y+\frac{1}{2}, x+\frac{1}{2}$ ;  
 $x\bar{y}\bar{z}$ ;  $\bar{x}, y, z+\frac{1}{2}$ ;  $x+\frac{1}{2}, \bar{y}, z$ ;  $x, y+\frac{1}{2}, \bar{z}$ ;  
 $\bar{x}\bar{y}z$ ;  $z+\frac{1}{2}, \bar{x}, y$ ;  $z, x+\frac{1}{2}, \bar{y}$ ;  $\bar{z}, x, y+\frac{1}{2}$ ;  
 $y\bar{x}\bar{z}$ ;  $y, z+\frac{1}{2}, \bar{x}$ ;  $\bar{y}, z, x+\frac{1}{2}$ ;  $y+\frac{1}{2}, \bar{z}, x$ ;  
 $y+\frac{1}{2}, x+\frac{1}{2}, z+\frac{1}{2}$ ;  $\frac{1}{2}-y, x+\frac{1}{2}, \frac{1}{2}-z$ ;  $y+\frac{1}{2}, \frac{1}{2}-x, \frac{1}{2}-z$ ;  
 $\frac{1}{2}-y, \frac{1}{2}-x, z+\frac{1}{2}$ ;  
 $x+\frac{1}{2}, z+\frac{1}{2}, y+\frac{1}{2}$ ;  $x+\frac{1}{2}, \frac{1}{2}-z, \frac{1}{2}-y$ ;  $\frac{1}{2}-x, \frac{1}{2}-z, y+\frac{1}{2}$ ;  
 $\frac{1}{2}-x, z+\frac{1}{2}, \frac{1}{2}-y$ ;  
 $z+\frac{1}{2}, y+\frac{1}{2}, x+\frac{1}{2}$ ;  $\frac{1}{2}-z, \frac{1}{2}-y, x+\frac{1}{2}$ ;  $\frac{1}{2}-z, y+\frac{1}{2}, \frac{1}{2}-x$ ;  
 $z+\frac{1}{2}, \frac{1}{2}-y, \frac{1}{2}-x$ ;  
 $x+\frac{1}{2}, y+\frac{1}{2}, z+\frac{1}{2}$ ;  $x+\frac{1}{2}, \frac{1}{2}-y, \bar{z}$ ;  $\bar{x}, y+\frac{1}{2}, \frac{1}{2}-z$ ;  
 $\frac{1}{2}-x, \bar{y}, z+\frac{1}{2}$ ;  
 $z+\frac{1}{2}, x+\frac{1}{2}, y+\frac{1}{2}$ ;  $\bar{z}, x+\frac{1}{2}, \frac{1}{2}-y$ ;  $\frac{1}{2}-z, \bar{x}, y+\frac{1}{2}$ ;  
 $z+\frac{1}{2}, \frac{1}{2}-x, \bar{y}$ ;  
 $y+\frac{1}{2}, z+\frac{1}{2}, x+\frac{1}{2}$ ;  $\frac{1}{2}-y, \bar{z}, x+\frac{1}{2}$ ;  $y+\frac{1}{2}, \frac{1}{2}-z, \bar{x}$ ;  
 $\bar{y}, z+\frac{1}{2}, \frac{1}{2}-x$ ;  
 $\frac{1}{2}-y, \frac{1}{2}-x, \frac{1}{2}-z$ ;  $y+\frac{1}{2}, \frac{1}{2}-x, z+\frac{1}{2}$ ;  $\frac{1}{2}-y, x+\frac{1}{2}, z+\frac{1}{2}$ ;  
 $y+\frac{1}{2}, x+\frac{1}{2}, \frac{1}{2}-z$ ;  
 $\frac{1}{2}-x, \frac{1}{2}-z, \frac{1}{2}-y$ ;  $\frac{1}{2}-x, z+\frac{1}{2}, y+\frac{1}{2}$ ;  $x+\frac{1}{2}, z+\frac{1}{2}, \frac{1}{2}-y$ ;  
 $x+\frac{1}{2}, \frac{1}{2}-z, y+\frac{1}{2}$ ;  
 $\frac{1}{2}-z, \frac{1}{2}-y, \frac{1}{2}-x$ ;  $z+\frac{1}{2}, y+\frac{1}{2}, \frac{1}{2}-x$ ;  $z+\frac{1}{2}, \frac{1}{2}-y, x+\frac{1}{2}$ ;  
 $\frac{1}{2}-z, y+\frac{1}{2}, x+\frac{1}{2}$ ;  
 $\frac{1}{2}-x, \frac{1}{2}-y, \frac{1}{2}-z$ ;  $\frac{1}{2}-x, y+\frac{1}{2}, z$ ;  $x, \frac{1}{2}-y, z+\frac{1}{2}$ ;  
 $x+\frac{1}{2}, y, \frac{1}{2}-z$ ;  
 $\frac{1}{2}-z, \frac{1}{2}-x, \frac{1}{2}-y$ ;  $z, \frac{1}{2}-x, y+\frac{1}{2}$ ;  $z+\frac{1}{2}, x, \frac{1}{2}-y$ ;  
 $z+\frac{1}{2}, x+\frac{1}{2}, y$ ;  
 $\frac{1}{2}-y, \frac{1}{2}-z, \frac{1}{2}-x$ ;  $y+\frac{1}{2}, z, \frac{1}{2}-x$ ;  $\frac{1}{2}-y, z+\frac{1}{2}, x$ ;  
 $y, \frac{1}{2}-z, x+\frac{1}{2}$ ;  
 $y+\frac{1}{2}, x+\frac{1}{2}, z+\frac{1}{2}$ ;  $\frac{1}{2}-y, x+\frac{1}{2}, \frac{1}{2}-z$ ;  $y+\frac{1}{2}, \frac{1}{2}-x, \frac{1}{2}-z$ ;  
 $\frac{1}{2}-y, \frac{1}{2}-x, z+\frac{1}{2}$ ;  
 $x+\frac{1}{2}, z+\frac{1}{2}, y+\frac{1}{2}$ ;  $x+\frac{1}{2}, \frac{1}{2}-z, \frac{1}{2}-y$ ;  $\frac{1}{2}-x, \frac{1}{2}-z, y+\frac{1}{2}$ ;  
 $\frac{1}{2}-x, z+\frac{1}{2}, \frac{1}{2}-y$ ;  
 $z+\frac{1}{2}, y+\frac{1}{2}, x+\frac{1}{2}$ ;  $\frac{1}{2}-z, \frac{1}{2}-y, x+\frac{1}{2}$ ;  $\frac{1}{2}-z, y+\frac{1}{2}, \frac{1}{2}-x$ ;  
 $z+\frac{1}{2}, \frac{1}{2}-y, \frac{1}{2}-x$ .

HEXAGONAL SYSTEM.  
RHOMBOHEDRAL DIVISION.

A. TETARTOHEDRY.

177 SPACE-GROUP  $C_3^1$ .—(Hexagonal Axes.)

*One* equivalent position:

(a) 0 0 u.      (b)  $\frac{1}{3} \frac{2}{3} u$ .      (c)  $\frac{2}{3} \frac{1}{3} u$ .

*Three* equivalent positions:

(d) xyz; y-x,  $\bar{x}$ , z;  $\bar{y}$ , x-y, z.

SPACE-GROUP  $C_3^2$ .—(Hexagonal Axes.)

*Three* equivalent positions:

(a) xyz; y-x,  $\bar{x}$ ,  $z+\frac{1}{3}$ ;  $\bar{y}$ , x-y,  $z+\frac{2}{3}$ .

SPACE-GROUP  $C_3^3$ .—(Hexagonal Axes.)

*Three* equivalent positions:

(a) xyz; y-x,  $\bar{x}$ ,  $z+\frac{2}{3}$ ;  $\bar{y}$ , x-y,  $z+\frac{1}{3}$ .

SPACE-GROUP  $C_3^4$ .—(Rhombohedral Axes.)

*One* equivalent position:

(a) u u u.

*Three* equivalent positions:

(b) xyz;  $\bar{x}y$ ;  $yzx$ .

B. HEXAGONAL TETARTOHEDRY OF THE SECOND SORT.

SPACE-GROUP  $C_{31}^1$ .—(Hexagonal Axes.)

*One* equivalent position:

(a) 0 0 0.      (b)  $0 0 \frac{1}{2}$ .

*Two* equivalent positions:

(c)  $0 0 u$ ;  $0 0 \bar{u}$ .      (d)  $\frac{1}{3} \frac{2}{3} u$ ;  $\frac{2}{3} \frac{1}{3} \bar{u}$ .

*Three* equivalent positions:

(e)  $\frac{1}{3} \frac{1}{3} \frac{1}{3}$ ;  $0 \frac{1}{3} \frac{1}{3}$ ;  $\frac{1}{3} 0 \frac{1}{3}$ .      (f)  $\frac{1}{3} \frac{1}{3} 0$ ;  $0 \frac{1}{3} 0$ ;  $\frac{1}{3} 0 0$ .

*Six* equivalent positions:

(g) xyz; y-x,  $\bar{x}$ , z;  $\bar{y}$ , x-y, z;  
 $\bar{x}\bar{y}\bar{z}$ ; x-y, x,  $\bar{z}$ ; y, y-x,  $\bar{z}$ .

SPACE-GROUP  $C_{31}^2$ .—(Rhombohedral Axes.)

*One* equivalent position:

(a) 0 0 0.      (b)  $\frac{1}{3} \frac{1}{3} \frac{1}{3}$ .

SPACE-GROUP  $C_{2h}^2$  (continued).

Two equivalent positions:

(c)  $u u u; \bar{u} \bar{u} \bar{u}$ .

Three equivalent positions:

(d)  $0 0 \frac{1}{2}; \frac{1}{2} 0 0; 0 \frac{1}{2} 0$ . (e)  $\frac{1}{2} \frac{1}{2} 0; 0 \frac{1}{2} \frac{1}{2}; \frac{1}{2} 0 \frac{1}{2}$ .

Six equivalent positions:

(f)  $xyz; zxy; yxz; \bar{x}\bar{y}\bar{z}; \bar{z}\bar{y}\bar{x}; \bar{y}\bar{x}\bar{z}$ .

## C. HEMIMORPHIC HEMIHEDRY.

SPACE-GROUP  $C_{3v}^1$ .—(Hexagonal Axes.)

One equivalent position:

(a)  $0 0 u$ . (b)  $\frac{1}{3} \frac{2}{3} u$ . (c)  $\frac{2}{3} \frac{1}{3} u$ .

Three equivalent positions:

(d)  $u \bar{u} v; 2\bar{u}, \bar{u}, v; u, 2u, v$ .

Six equivalent positions:

(e)  $xyz; y-x, \bar{x}, z; \bar{y}, x-y, z;$   
 $\bar{y}\bar{x}z; x, x-y, z; y-x, y, z$ .

SPACE-GROUP  $C_{3v}^2$ .—(Hexagonal Axes.)

One equivalent position:

(a)  $0 0 u$ .

Two equivalent positions:

(b)  $\frac{1}{3} \frac{2}{3} u; \frac{2}{3} \frac{1}{3} u$ .

Three equivalent positions:

(c)  $u u v; 0 \bar{u} v; \bar{u} 0 v$ .

Six equivalent positions:

(d)  $xyz; y-x, \bar{x}, z; \bar{y}, x-y, z;$   
 $yxz; \bar{x}, y-x, z; x-y, \bar{y}, z$ .

SPACE-GROUP  $C_{3v}^3$ .—(Hexagonal Axes.)

Two equivalent positions:

(a)  $0 0 u; 0, 0, u+\frac{1}{3}$ . (c)  $\frac{2}{3} \frac{1}{3} u; \frac{1}{3}, \frac{1}{3}, u+\frac{1}{3}$ .  
(b)  $\frac{1}{3} \frac{2}{3} u; \frac{1}{3}, \frac{2}{3}, u+\frac{1}{3}$ .

Six equivalent positions:

(d)  $xyz; y-x, \bar{x}, z; \bar{y}, x-y, z;$   
 $x, x-y, z+\frac{1}{3}; \bar{y}, \bar{x}, z+\frac{1}{3}; y-x, y, z+\frac{1}{3}$ .

SPACE-GROUP  $C_{3v}^4$ .—(Hexagonal Axes.)

Two equivalent positions:

(a)  $00u$ ;  $0, 0, u+\frac{1}{2}$ .      (b)  $\frac{1}{3}\frac{2}{3}u$ ;  $\frac{2}{3}, \frac{1}{3}, u+\frac{1}{2}$ .

Six equivalent positions:

(c)  $xyz$ ;       $y-x, \bar{x}, z$ ;       $\bar{y}, x-y, z$ ;  
 $y, x, z+\frac{1}{2}$ ;       $\bar{x}, y-x, z+\frac{1}{2}$ ;       $x-y, \bar{y}, z+\frac{1}{2}$ .

SPACE-GROUP  $C_{3v}^5$ .—(Rhombohedral Axes.)

One equivalent position:

(a)  $uuu$ .

Three equivalent positions:

(b)  $uuv$ ;  $vuu$ ;  $uvu$ .

Six equivalent positions:

(c)  $xyz$ ;  $zxy$ ;  $yzx$ ;       $xzy$ ;  $zyx$ ;  $yxz$ .

SPACE-GROUP  $C_{3v}^6$ .—(Rhombohedral Axes.)

Two equivalent positions:

(a)  $uuu$ ;  $u+\frac{1}{2}, u+\frac{1}{2}, u+\frac{1}{2}$ .

Six equivalent positions:

(b)  $xyz$ ;       $zxy$ ;       $yzx$ ;  
 $x+\frac{1}{2}, z+\frac{1}{2}, y+\frac{1}{2}$ ;       $z+\frac{1}{2}, y+\frac{1}{2}, x+\frac{1}{2}$ ;       $y+\frac{1}{2}, x+\frac{1}{2}, z+\frac{1}{2}$ .

D. ENANTIOMORPHIC HEMIHEDRY.

SPACE-GROUP  $D_3^1$ .—(Hexagonal Axes.)

One equivalent position:

(a)  $000$ .      (c)  $\frac{1}{3}\frac{2}{3}0$ .      (e)  $\frac{2}{3}\frac{1}{3}0$ .  
 (b)  $00\frac{1}{2}$ .      (d)  $\frac{1}{3}\frac{2}{3}\frac{1}{2}$ .      (f)  $\frac{2}{3}\frac{1}{3}\frac{1}{2}$ .

Two equivalent positions:

(g)  $00u$ ;  $00\bar{u}$ .      (i)  $\frac{2}{3}\frac{1}{3}u$ ;  $\frac{2}{3}\frac{1}{3}\bar{u}$ .  
 (h)  $\frac{1}{3}\frac{2}{3}u$ ;  $\frac{1}{3}\frac{2}{3}\bar{u}$ .

Three equivalent positions:

(j)  $u\bar{u}0$ ;  $2u, \bar{u}, 0$ ;  $u, 2u, 0$ .  
 (k)  $u\bar{u}\frac{1}{2}$ ;  $2u, \bar{u}, \frac{1}{2}$ ;  $u, 2u, \frac{1}{2}$ .

Six equivalent positions:

(l)  $xyz$ ;       $y-x, \bar{x}, z$ ;       $\bar{y}, x-y, z$ ;  
 $x, x-y, \bar{z}$ ;       $\bar{y}\bar{x}\bar{z}$ ;       $y-x, y, \bar{z}$ .



SPACE-GROUP  $D_3^2$ .—(Hexagonal Axes.)*One* equivalent position:

(a) 000.            (b)  $00\frac{1}{2}$ .

*Two* equivalent positions:

(c) 00u; 00 $\bar{u}$ .            (d)  $\frac{1}{2}\frac{2}{3}u$ ;  $\frac{2}{3}\frac{1}{3}\bar{u}$ .

*Three* equivalent positions:

(e) uu0; 0 $\bar{u}$ 0;  $\bar{u}$ 00.            (f)  $uu\frac{1}{2}$ ; 0 $\bar{u}\frac{1}{2}$ ;  $\bar{u}0\frac{1}{2}$ .

*Six* equivalent positions:

(g) xyz; y-x,  $\bar{x}$ , z;  $\bar{y}$ , x-y, z;  
yx $\bar{z}$ ;  $\bar{x}$ , y-x,  $\bar{z}$ ; x-y,  $\bar{y}$ ,  $\bar{z}$ .

SPACE-GROUP  $D_3^3$ .—(Hexagonal Axes.)*Three* equivalent positions:

(a)  $u\bar{u}\frac{1}{2}$ ; 2 $\bar{u}$ ,  $\bar{u}$ ,  $\frac{2}{3}$ ; u, 2u, 0.

(b)  $u\bar{u}\frac{2}{3}$ ; 2 $\bar{u}$ ,  $\bar{u}$ ,  $\frac{1}{3}$ ; u, 2u,  $\frac{1}{2}$ .

*Six* equivalent positions:

(c) xyz;            y-x,  $\bar{x}$ ,  $z+\frac{1}{2}$ ;  $\bar{y}$ , x-y,  $z+\frac{2}{3}$ ;  
y-x, y,  $\bar{z}$ ;  $\bar{y}$ ,  $\bar{x}$ ,  $\frac{2}{3}-z$ ;    x, x-y,  $\frac{1}{3}-z$ .

SPACE-GROUP  $D_3^4$ .—(Hexagonal Axes.)*Three* equivalent positions:

(a) u00;  $\bar{u}\bar{u}\frac{1}{2}$ ; 0 $u\frac{2}{3}$ .            (b)  $u0\frac{1}{2}$ ;  $\bar{u}\bar{u}\frac{2}{3}$ ; 0 $u\frac{1}{2}$ .

*Six* equivalent positions:

(c) xyz;            y-x,  $\bar{x}$ ,  $z+\frac{1}{2}$ ;  $\bar{y}$ , x-y,  $z+\frac{2}{3}$ ;  
x-y,  $\bar{y}$ ,  $\bar{z}$ ; y, x,  $\frac{2}{3}-z$ ;     $\bar{x}$ , y-x,  $\frac{1}{3}-z$ .

SPACE-GROUP  $D_3^5$ .—(Hexagonal Axes.)*Three* equivalent positions:

(a)  $u\bar{u}\frac{1}{2}$ ; 2 $\bar{u}$ ,  $\bar{u}$ ,  $\frac{2}{3}$ ; u, 2u,  $\frac{1}{2}$ .

(b)  $u\bar{u}\frac{2}{3}$ ; 2 $\bar{u}$ ,  $\bar{u}$ ,  $\frac{1}{3}$ ; u, 2u, 0.

*Six* equivalent positions:

(c) xyz;            y-x,  $\bar{x}$ ,  $z+\frac{2}{3}$ ;  $\bar{y}$ , x-y,  $z+\frac{1}{2}$ ;  
y-x, y,  $\bar{z}$ ;  $\bar{y}$ ,  $\bar{x}$ ,  $\frac{1}{3}-z$ ;    x, x-y,  $\frac{2}{3}-z$ .

SPACE-GROUP  $D_3^6$ .—(Hexagonal Axes.)*Three* equivalent positions:

(a) u00; 0 $u\frac{1}{2}$ ;  $\bar{u}\bar{u}\frac{2}{3}$ .            (b)  $u0\frac{1}{2}$ ; 0 $u\frac{2}{3}$ ;  $\bar{u}\bar{u}\frac{1}{2}$ .

*Six* equivalent positions:

(c) xyz;            y-x,  $\bar{x}$ ,  $z+\frac{2}{3}$ ;  $\bar{y}$ , x-y,  $z+\frac{1}{2}$ ;  
x-y,  $\bar{y}$ ,  $\bar{z}$ ; y, x,  $\frac{1}{3}-z$ ;     $\bar{x}$ , y-x,  $\frac{2}{3}-z$ .

SPACE-GROUP  $D_3^7$ .—(Rhombohedral Axes.)*One* equivalent position:

(a)  $000$ .            (b)  $\frac{1}{2}\frac{1}{2}\frac{1}{2}$ .

*Two* equivalent positions:

(c)  $uuu$ ;  $\bar{u}\bar{u}\bar{u}$ .

*Three* equivalent positions:

(d)  $u\bar{u}0$ ;  $\bar{u}0u$ ;  $0u\bar{u}$ .            (e)  $u\bar{u}\frac{1}{2}$ ;  $\bar{u}\frac{1}{2}u$ ;  $\frac{1}{2}u\bar{u}$ .

*Six* equivalent positions:

(f)  $xyz$ ;  $yzx$ ;  $zxy$ ;  $\bar{y}\bar{x}\bar{z}$ ;  $\bar{x}\bar{z}\bar{y}$ ;  $\bar{z}\bar{y}\bar{x}$ .

## E. HOLOHEDRY.

SPACE-GROUP  $D_{3d}^1$ .—(Hexagonal Axes.)*One* equivalent position:

(a)  $000$ .            (b)  $00\frac{1}{2}$ .

*Two* equivalent positions:

(c)  $\frac{1}{2}\frac{2}{3}0$ ;  $\frac{2}{3}\frac{1}{3}0$ .            (e)  $00u$ ;  $00\bar{u}$ .  
(d)  $\frac{1}{2}\frac{2}{3}\frac{1}{2}$ ;  $\frac{2}{3}\frac{1}{3}\frac{1}{2}$ .

*Three* equivalent positions:

(f)  $\frac{1}{2}\frac{1}{2}0$ ;  $0\frac{1}{2}0$ ;  $\frac{1}{2}00$ .            (g)  $\frac{1}{2}\frac{1}{2}\frac{1}{2}$ ;  $0\frac{1}{2}\frac{1}{2}$ ;  $\frac{1}{2}0\frac{1}{2}$ .

*Four* equivalent positions:

(h)  $\frac{1}{2}\frac{2}{3}u$ ;  $\frac{1}{2}\frac{2}{3}\bar{u}$ ;  $\frac{2}{3}\frac{1}{3}u$ ;  $\frac{2}{3}\frac{1}{3}\bar{u}$ .

*Six* equivalent positions:

(i)  $u\bar{u}0$ ;  $2\bar{u}, \bar{u}, 0$ ;  $u, 2u, 0$ ;  $\bar{u}u0$ ;  $2u, u, 0$ ;  $\bar{u}, 2\bar{u}, 0$ .  
(j)  $u\bar{u}\frac{1}{2}$ ;  $2\bar{u}, \bar{u}, \frac{1}{2}$ ;  $u, 2u, \frac{1}{2}$ ;  $\bar{u}u\frac{1}{2}$ ;  $2u, u, \frac{1}{2}$ ;  $\bar{u}, 2\bar{u}, \frac{1}{2}$ .  
(k)  $uuv$ ;  $0\bar{u}\bar{v}$ ;  $\bar{u}0\bar{v}$ ;  $u0\bar{v}$ ;  $\bar{u}\bar{u}\bar{v}$ ;  $0u\bar{v}$ .

*Twelve* equivalent positions:

(l)  $xyz$ ;  $y-x, \bar{x}, z$ ;  $\bar{y}, x-y, z$ ;  $x, x-y, \bar{z}$ ;  $\bar{y}\bar{x}\bar{z}$ ;  $y-x, y, \bar{z}$ ;  
 $\bar{x}\bar{y}\bar{z}$ ;  $x-y, x, \bar{z}$ ;  $y, y-x, \bar{z}$ ;  $\bar{x}, y-x, z$ ;  $yxz$ ;  $x-y, \bar{y}, z$ .

SPACE-GROUP  $D_{3d}^2$ .—(Hexagonal Axes.)*Two* equivalent positions:

(a)  $000$ ;  $00\frac{1}{2}$ .            (c)  $\frac{1}{2}\frac{2}{3}0$ ;  $\frac{2}{3}\frac{1}{3}\frac{1}{2}$ .  
(b)  $00\frac{1}{4}$ ;  $00\frac{3}{4}$ .            (d)  $\frac{1}{2}\frac{2}{3}\frac{1}{2}$ ;  $\frac{2}{3}\frac{1}{3}0$ .

*Four* equivalent positions:

(e)  $00u$ ;  $00\bar{u}$ ;  $0, 0, \frac{1}{2}-u$ ;  $0, 0, u+\frac{1}{2}$ .  
(f)  $\frac{1}{2}\frac{2}{3}u$ ;  $\frac{1}{2}\frac{2}{3}\bar{u}$ ;  $\frac{2}{3}, \frac{1}{3}, \frac{1}{2}-u$ ;  $\frac{2}{3}, \frac{1}{3}, u+\frac{1}{2}$ .

SPACE-GROUP  $D_{3d}^2$  (continued).*Six* equivalent positions:

(g)  $\frac{1}{2}\frac{1}{2}\frac{1}{2}$ ;  $0\frac{1}{2}\frac{1}{2}$ ;  $\frac{1}{2}0\frac{1}{2}$ ;  $\frac{1}{2}0\frac{1}{2}$ ;  $\frac{1}{2}\frac{1}{2}\frac{1}{2}$ ;  $0\frac{1}{2}\frac{1}{2}$ .

(h)  $u\bar{u}0$ ;  $2\bar{u}, \bar{u}, 0$ ;  $u, 2u, 0$ ;  $\bar{u}u\frac{1}{2}$ ;  $2u, u, \frac{1}{2}$ ;  $\bar{u}, 2\bar{u}, \frac{1}{2}$ .

*Twelve* equivalent positions:

(i)  $xyz$ ;  $y-x, \bar{x}, z$ ;  $\bar{y}, x-y, z$ ;  
 $x, x-y, \bar{z}$ ;  $\bar{y}\bar{x}\bar{z}$ ;  $y-x, y, \bar{z}$ ;  
 $\bar{x}, \bar{y}, \frac{1}{2}-z$ ;  $x-y, x, \frac{1}{2}-z$ ;  $y, y-x, \frac{1}{2}-z$ ;  
 $\bar{x}, y-x, z+\frac{1}{2}$ ;  $y, x, z+\frac{1}{2}$ ;  $x-y, \bar{y}, z+\frac{1}{2}$ .

SPACE-GROUP  $D_{3d}^3$ .—(Hexagonal Axes.)*One* equivalent position:

(a)  $000$ . (b)  $00\frac{1}{2}$ .

*Two* equivalent positions:

(c)  $00u$ ;  $00\bar{u}$ . (d)  $\frac{1}{2}\frac{2}{3}u$ ;  $\frac{2}{3}\frac{1}{3}\bar{u}$ .

*Three* equivalent positions:

(e)  $\frac{1}{2}\frac{1}{2}0$ ;  $0\frac{1}{2}0$ ;  $\frac{1}{2}00$ . (f)  $\frac{1}{2}\frac{1}{2}\frac{1}{2}$ ;  $0\frac{1}{2}\frac{1}{2}$ ;  $\frac{1}{2}0\frac{1}{2}$ .

*Six* equivalent positions:

(g)  $uu0$ ;  $0\bar{u}0$ ;  $\bar{u}00$ ;  $\bar{u}\bar{u}0$ ;  $0u0$ ;  $u00$ .

(h)  $uu\frac{1}{2}$ ;  $0\bar{u}\frac{1}{2}$ ;  $\bar{u}0\frac{1}{2}$ ;  $\bar{u}\bar{u}\frac{1}{2}$ ;  $0u\frac{1}{2}$ ;  $u0\frac{1}{2}$ .

(i)  $u\bar{u}v$ ;  $2\bar{u}, \bar{u}, v$ ;  $u, 2u, v$ ;  $\bar{u}u\bar{v}$ ;  $2u, u, \bar{v}$ ;  $\bar{u}, 2\bar{u}, \bar{v}$ .

*Twelve* equivalent positions:

(j)  $xyz$ ;  $y-x, \bar{x}, z$ ;  $\bar{y}, x-y, z$ ;  
 $\bar{x}, y-x, \bar{z}$ ;  $yx\bar{z}$ ;  $x-y, \bar{y}, \bar{z}$ ;  
 $\bar{x}\bar{y}\bar{z}$ ;  $x-y, x, \bar{z}$ ;  $y, y-x, \bar{z}$ ;  
 $x, x-y, z$ ;  $\bar{y}\bar{x}z$ ;  $y-x, y, z$ .

SPACE-GROUP  $D_{3d}^4$ .—(Hexagonal Axes.)*Two* equivalent positions:

(a)  $000$ ;  $00\frac{1}{2}$ . (b)  $00\frac{1}{2}$ ;  $00\frac{1}{2}$ .

*Four* equivalent positions:

(c)  $00u$ ;  $00\bar{u}$ ;  $0, 0, \frac{1}{2}-u$ ;  $0, 0, u+\frac{1}{2}$ .

(d)  $\frac{1}{2}\frac{2}{3}u$ ;  $\frac{2}{3}\frac{1}{3}\bar{u}$ ;  $\frac{2}{3}, \frac{1}{3}, \frac{1}{2}-u$ ;  $\frac{1}{3}, \frac{2}{3}, u+\frac{1}{2}$ .

*Six* equivalent positions:

(e)  $0\frac{1}{2}\frac{1}{2}$ ;  $\frac{1}{2}0\frac{1}{2}$ ;  $\frac{1}{2}\frac{1}{2}\frac{1}{2}$ ;  $0\frac{1}{2}\frac{1}{2}$ ;  $\frac{1}{2}0\frac{1}{2}$ ;  $\frac{1}{2}\frac{1}{2}\frac{1}{2}$ .

(f)  $uu0$ ;  $0\bar{u}0$ ;  $\bar{u}00$ ;  $\bar{u}\bar{u}\frac{1}{2}$ ;  $0u\frac{1}{2}$ ;  $u0\frac{1}{2}$ .

*Twelve* equivalent positions:

(g)  $xyz$ ;  $y-x, \bar{x}, z$ ;  $\bar{y}, x-y, z$ ;  
 $\bar{x}, y-x, \bar{z}$ ;  $yx\bar{z}$ ;  $x-y, \bar{y}, \bar{z}$ ;  
 $\bar{x}, \bar{y}, \frac{1}{2}-z$ ;  $x-y, x, \frac{1}{2}-z$ ;  $y, y-x, \frac{1}{2}-z$ ;  
 $x, x-y, z+\frac{1}{2}$ ;  $\bar{y}, \bar{x}, z+\frac{1}{2}$ ;  $y-x, y, z+\frac{1}{2}$ .

SPACE-GROUP  $D_{3d}^5$ .—(Rhombohedral Axes.)

One equivalent position:

- (a) 0 0 0.            (b)  $\frac{1}{2} \frac{1}{2} \frac{1}{2}$ .

Two equivalent positions:

- (c) u u u;  $\bar{u} \bar{u} \bar{u}$ .

Three equivalent positions:

- (d)  $0 0 \frac{1}{2}$ ;  $0 \frac{1}{2} 0$ ;  $\frac{1}{2} 0 0$ .            (e)  $\frac{1}{2} \frac{1}{2} 0$ ;  $\frac{1}{2} 0 \frac{1}{2}$ ;  $0 \frac{1}{2} \frac{1}{2}$ .

Six equivalent positions:

- (f) u  $\bar{u}$  0;  $\bar{u}$  0 u; 0 u  $\bar{u}$ ;  $\bar{u}$  u 0; u 0  $\bar{u}$ ; 0  $\bar{u}$  u.  
 (g) u  $\bar{u} \frac{1}{2}$ ;  $\bar{u} \frac{1}{2}$  u;  $\frac{1}{2}$  u  $\bar{u}$ ;  $\bar{u}$  u  $\frac{1}{2}$ ; u  $\frac{1}{2}$   $\bar{u}$ ;  $\frac{1}{2}$   $\bar{u}$  u.  
 (h) u u v; u v u; v u u;  $\bar{u} \bar{u} \bar{v}$ ;  $\bar{u} \bar{v} \bar{u}$ ;  $\bar{v} \bar{u} \bar{u}$ .

Twelve equivalent positions:

- (i) xyz; yzx; zxy;  $\bar{y}\bar{x}\bar{z}$ ;  $\bar{x}\bar{z}\bar{y}$ ;  $\bar{z}\bar{y}\bar{x}$ ;  
 $\bar{x}\bar{y}\bar{z}$ ;  $\bar{y}\bar{z}\bar{x}$ ;  $\bar{z}\bar{x}\bar{y}$ ; yxz; xzy; zyx.

203 SPACE-GROUP  $D_{3d}^6$ .—(Rhombohedral Axes.)

Two equivalent positions:

- (a) 0 0 0;  $\frac{1}{2} \frac{1}{2} \frac{1}{2}$ .            (b)  $\frac{1}{3} \frac{1}{3} \frac{1}{3}$ ;  $\frac{2}{3} \frac{2}{3} \frac{2}{3}$ .

Four equivalent positions:

- (c) u u u;  $\bar{u} \bar{u} \bar{u}$ ;  $\frac{1}{2}-u$ ,  $\frac{1}{2}-u$ ,  $\frac{1}{2}-u$ ;  $u+\frac{1}{2}$ ,  $u+\frac{1}{2}$ ,  $u+\frac{1}{2}$ .

Six equivalent positions:

- (d)  $\frac{1}{3} \frac{2}{3} \frac{2}{3}$ ;  $\frac{2}{3} \frac{1}{3} \frac{1}{3}$ ;  $\frac{2}{3} \frac{2}{3} \frac{1}{3}$ ;  $\frac{1}{3} \frac{1}{3} \frac{2}{3}$ ;  $\frac{2}{3} \frac{1}{3} \frac{2}{3}$ ;  $\frac{1}{3} \frac{2}{3} \frac{1}{3}$ .  
 (e) u  $\bar{u}$  0;  $\bar{u}$  0 u; 0 u  $\bar{u}$ ;  
 $\frac{1}{2}-u$ ,  $u+\frac{1}{2}$ ,  $\frac{1}{2}$ ;  $u+\frac{1}{2}$ ,  $\frac{1}{2}$ ,  $\frac{1}{2}-u$ ;  $\frac{1}{2}$ ,  $\frac{1}{2}-u$ ,  $u+\frac{1}{2}$ .

Twelve equivalent positions:

- (f) xyz; yzx; zxy;  
 $\bar{y}\bar{x}\bar{z}$ ;  $\bar{x}\bar{z}\bar{y}$ ;  $\bar{z}\bar{y}\bar{x}$ ;  
 $\frac{1}{2}-x$ ,  $\frac{1}{2}-y$ ,  $\frac{1}{2}-z$ ;  $\frac{1}{2}-y$ ,  $\frac{1}{2}-z$ ,  $\frac{1}{2}-x$ ;  $\frac{1}{2}-z$ ,  $\frac{1}{2}-x$ ,  $\frac{1}{2}-y$ ;  
 $y+\frac{1}{2}$ ,  $x+\frac{1}{2}$ ,  $z+\frac{1}{2}$ ;  $x+\frac{1}{2}$ ,  $z+\frac{1}{2}$ ,  $y+\frac{1}{2}$ ;  $z+\frac{1}{2}$ ,  $y+\frac{1}{2}$ ,  $x+\frac{1}{2}$ .

HEXAGONAL DIVISION.

A. TRIGONAL PARAMORPHIC HEMIHEDRY.

SPACE-GROUP  $C_{3h}^1$ .—(Hexagonal Axes.)

One equivalent position:

- (a) 0 0 0.            (c)  $\frac{1}{3} \frac{2}{3} 0$ .            (e)  $\frac{2}{3} \frac{1}{3} 0$ .  
 (b)  $0 0 \frac{1}{2}$ .            (d)  $\frac{1}{3} \frac{2}{3} \frac{1}{2}$ .            (f)  $\frac{2}{3} \frac{1}{3} \frac{1}{2}$ .

Two equivalent positions:

- (g) 0 0 u; 0 0  $\bar{u}$ .            (i)  $\frac{2}{3} \frac{1}{3} u$ ;  $\frac{2}{3} \frac{1}{3} \bar{u}$ .  
 (h)  $\frac{1}{3} \frac{2}{3} u$ ;  $\frac{1}{3} \frac{2}{3} \bar{u}$ .

SPACE-GROUP  $C_m^1$  (continued).

Three equivalent positions:

(j)  $u v 0; v-u, \bar{u}, 0; \bar{v}, u-v, 0.$

(k)  $u v \frac{1}{2}; v-u, \bar{u}, \frac{1}{2}; \bar{v}, u-v, \frac{1}{2}.$

Six equivalent positions:

(l)  $xyz; y-x, \bar{x}, z; \bar{y}, x-y, z;$

$xy\bar{z}; y-x, \bar{x}, \bar{z}; \bar{y}, x-y, \bar{z}.$

## B. HEMIHEDRY WITH A THREE-FOLD AXIS.

(Trigonal Holohedry.)

SPACE-GROUP  $D_{3h}^1$ .—(Hexagonal Axes.)

One equivalent position:

(a)  $0 0 0.$  (c)  $\frac{1}{3} \frac{2}{3} 0.$  (e)  $\frac{2}{3} \frac{1}{3} 0.$

(b)  $0 0 \frac{1}{2}.$  (d)  $\frac{1}{3} \frac{2}{3} \frac{1}{2}.$  (f)  $\frac{2}{3} \frac{1}{3} \frac{1}{2}.$

Two equivalent positions:

(g)  $0 0 u; 0 0 \bar{u}.$  (i)  $\frac{2}{3} \frac{1}{3} u; \frac{2}{3} \frac{1}{3} \bar{u}.$

(h)  $\frac{1}{3} \frac{2}{3} u; \frac{1}{3} \frac{2}{3} \bar{u}.$

Three equivalent positions:

(j)  $u \bar{u} 0; 2\bar{u}, \bar{u}, 0; u, 2u, 0.$

(k)  $u \bar{u} \frac{1}{2}; 2\bar{u}, \bar{u}, \frac{1}{2}; u, 2u, \frac{1}{2}.$

Six equivalent positions:

(l)  $u v 0; v-u, \bar{u}, 0; \bar{v}, u-v, 0;$

$u, u-v, 0; \bar{v} \bar{u} 0; v-u, v, 0.$

(m)  $u v \frac{1}{2}; v-u, \bar{u}, \frac{1}{2}; \bar{v}, u-v, \frac{1}{2};$

$u, u-v, \frac{1}{2}; \bar{v} \bar{u} \frac{1}{2}; v-u, v, \frac{1}{2}.$

(n)  $u \bar{u} v; 2\bar{u}, \bar{u}, v; u, 2u, v; u \bar{u} \bar{v}; 2\bar{u}, \bar{u}, \bar{v}; u, 2u, \bar{v}.$

Twelve equivalent positions:

(o)  $xyz; y-x, \bar{x}, z; \bar{y}, x-y, z;$

$x, x-y, \bar{z}; \bar{y}\bar{x}\bar{z}; y-x, y, \bar{z};$

$xy\bar{z}; y-x, \bar{x}, \bar{z}; \bar{y}, x-y, \bar{z};$

$x, x-y, z; \bar{y}\bar{x}z; y-x, y, z.$

SPACE-GROUP  $D_{3h}^2$ .—(Hexagonal Axes.)

Two equivalent positions:

(a)  $0 0 0; 0 0 \frac{1}{2}.$  (d)  $\frac{1}{3} \frac{2}{3} \frac{1}{2}; \frac{1}{3} \frac{2}{3} \frac{2}{2}.$

(b)  $0 0 \frac{1}{2}; 0 0 \frac{2}{2}.$  (e)  $\frac{2}{3} \frac{1}{3} 0; \frac{2}{3} \frac{1}{3} \frac{1}{2}.$

(c)  $\frac{1}{3} \frac{2}{3} 0; \frac{1}{3} \frac{2}{3} \frac{1}{2}.$  (f)  $\frac{2}{3} \frac{1}{3} \frac{1}{2}; \frac{2}{3} \frac{1}{3} \frac{2}{2}.$

Four equivalent positions:

(g)  $0 0 u; 0 0 \bar{u}; 0, 0, \frac{1}{2}-u; 0, 0, u+\frac{1}{2}.$

(h)  $\frac{1}{3} \frac{2}{3} u; \frac{1}{3} \frac{2}{3} \bar{u}; \frac{1}{3}, \frac{2}{3}, \frac{1}{2}-u; \frac{1}{3}, \frac{2}{3}, u+\frac{1}{2}.$

(i)  $\frac{2}{3} \frac{1}{3} u; \frac{2}{3} \frac{1}{3} \bar{u}; \frac{2}{3}, \frac{1}{3}, \frac{1}{2}-u; \frac{2}{3}, \frac{1}{3}, u+\frac{1}{2}.$

SPACE-GROUP  $D_{2h}^3$  (continued).

Six equivalent positions:

- (j)  $u \bar{u} 0$ ;  $2\bar{u}, \bar{u}, 0$ ;  $u, 2u, 0$ ;  $u \bar{u} \frac{1}{2}$ ;  $2\bar{u}, \bar{u}, \frac{1}{2}$ ;  $u, 2u, \frac{1}{2}$ .  
 (k)  $u v \frac{1}{2}$ ;  $v-u, \bar{u}, \frac{1}{2}$ ;  $\bar{v}, u-v, \frac{1}{2}$ ;  
 $u, u-v, \frac{1}{2}$ ;  $\bar{v} \bar{u} \frac{1}{2}$ ;  $v-u, v, \frac{1}{2}$ .

Twelve equivalent positions:

- (l)  $xyz$ ;  $y-x, \bar{x}, z$ ;  $\bar{y}, x-y, z$ ;  
 $x, x-y, \bar{z}$ ;  $\bar{y}\bar{x}\bar{z}$ ;  $y-x, y, \bar{z}$ ;  
 $x, y, \frac{1}{2}-z$ ;  $y-x, \bar{x}, \frac{1}{2}-z$ ;  $\bar{y}, x-y, \frac{1}{2}-z$ ;  
 $x, x-y, z+\frac{1}{2}$ ;  $\bar{y}, \bar{x}, z+\frac{1}{2}$ ;  $y-x, y, z+\frac{1}{2}$ .

SPACE-GROUP  $D_{2h}^4$ .—(Hexagonal Axes.)

One equivalent position:

- (a)  $000$ . (b)  $00\frac{1}{2}$ .

Two equivalent positions:

- (c)  $\frac{1}{2}\frac{2}{3}0$ ;  $\frac{2}{3}\frac{1}{3}0$ . (e)  $00u$ ;  $00\bar{u}$ .  
 (d)  $\frac{1}{2}\frac{2}{3}\frac{1}{2}$ ;  $\frac{2}{3}\frac{1}{3}\frac{1}{2}$ .

Three equivalent positions:

- (f)  $uu0$ ;  $0\bar{u}0$ ;  $\bar{u}00$ . (g)  $uu\frac{1}{2}$ ;  $0\bar{u}\frac{1}{2}$ ;  $\bar{u}0\frac{1}{2}$ .

Four equivalent positions:

- (h)  $\frac{1}{2}\frac{2}{3}u$ ;  $\frac{2}{3}\frac{1}{3}\bar{u}$ ;  $\frac{1}{2}\frac{2}{3}\bar{u}$ ;  $\frac{2}{3}\frac{1}{3}u$ .

Six equivalent positions:

- (i)  $uuv$ ;  $0\bar{u}v$ ;  $\bar{u}0v$ ;  $\bar{u}0\bar{v}$ ;  $uuv$ ;  $0\bar{u}\bar{v}$ .  
 (j)  $uv0$ ;  $v-u, \bar{u}, 0$ ;  $\bar{v}, u-v, 0$ ;  
 $v\bar{u}0$ ;  $\bar{u}, v-u, 0$ ;  $u-v, \bar{v}, 0$ .  
 (k)  $uv\frac{1}{2}$ ;  $v-u, \bar{u}, \frac{1}{2}$ ;  $\bar{v}, u-v, \frac{1}{2}$ ;  
 $v\bar{u}\frac{1}{2}$ ;  $\bar{u}, v-u, \frac{1}{2}$ ;  $u-v, \bar{v}, \frac{1}{2}$ .

Twelve equivalent positions:

- (l)  $xyz$ ;  $y-x, \bar{x}, z$ ;  $\bar{y}, x-y, z$ ;  
 $\bar{x}, y-x, \bar{z}$ ;  $yx\bar{z}$ ;  $x-y, \bar{y}, \bar{z}$ ;  
 $xy\bar{z}$ ;  $y-x, \bar{x}, \bar{z}$ ;  $\bar{y}, x-y, \bar{z}$ ;  
 $\bar{x}, y-x, z$ ;  $yxz$ ;  $x-y, \bar{y}, z$ .

SPACE-GROUP  $D_{2h}^4$ .—(Hexagonal Axes.)

Two equivalent positions:

- (a)  $000$ ;  $00\frac{1}{2}$ . (c)  $\frac{1}{2}\frac{2}{3}\frac{1}{2}$ ;  $\frac{2}{3}\frac{1}{3}\frac{1}{2}$ .  
 (b)  $00\frac{1}{2}$ ;  $00\frac{1}{2}$ . (d)  $\frac{1}{2}\frac{2}{3}\frac{1}{2}$ ;  $\frac{2}{3}\frac{1}{3}\frac{1}{2}$ .

Four equivalent positions:

- (e)  $00u$ ;  $00\bar{u}$ ;  $0, 0, \frac{1}{2}-u$ ;  $0, 0, u+\frac{1}{2}$ .  
 (f)  $\frac{1}{2}\frac{2}{3}u$ ;  $\frac{2}{3}\frac{1}{3}\bar{u}$ ;  $\frac{1}{2}, \frac{2}{3}, \frac{1}{2}-u$ ;  $\frac{2}{3}, \frac{1}{3}, u+\frac{1}{2}$ .

SPACE-GROUP  $D_2^4$  (continued).*Six* equivalent positions:

(g)  $u u 0; 0 \bar{u} 0; \bar{u} 0 0; u u \frac{1}{2}; 0 \bar{u} \frac{1}{2}; \bar{u} 0 \frac{1}{2}.$

(h)  $u v \frac{1}{2}; v-u, \bar{u}, \frac{1}{2}; \bar{v}, u-v, \frac{1}{2};$   
 $v u \frac{1}{2}; \bar{u}, v-u, \frac{1}{2}; u-v, \bar{v}, \frac{1}{2}.$

*Twelve* equivalent positions:

(i)  $xyz; y-x, \bar{x}, z; \bar{y}, x-y, z;$   
 $\bar{x}, y-x, \bar{z}; yx\bar{z}; x-y, \bar{y}, \bar{z};$   
 $x, y, \frac{1}{2}-z; y-x, \bar{x}, \frac{1}{2}-z; \bar{y}, x-y, \frac{1}{2}-z;$   
 $\bar{x}, y-x, z+\frac{1}{2}; y, x, z+\frac{1}{2}; x-y, \bar{y}, z+\frac{1}{2}.$

## C. HEXAGONAL TETARTOEDRY.

SPACE-GROUP  $C_6^1$ .—(Hexagonal Axes.)*One* equivalent position:

(a)  $0 0 u.$

*Two* equivalent positions:

(b)  $\frac{1}{2} \frac{2}{3} u; \frac{2}{3} \frac{1}{3} u.$

*Three* equivalent positions:

(c)  $\frac{1}{2} \frac{1}{2} u; 0 \frac{1}{2} u; \frac{1}{2} 0 u.$

*Six* equivalent positions:

(d)  $xyz; y-x, \bar{x}, z; \bar{y}, x-y, z;$   
 $\bar{x}\bar{y}z; x-y, x, z; y, y-x, z.$

SPACE-GROUP  $C_6^2$ .—(Hexagonal Axes.)*Six* equivalent positions:

(a)  $xyz; y-x, \bar{x}, z+\frac{1}{2}; \bar{y}, x-y, z+\frac{1}{2};$   
 $\bar{x}, \bar{y}, z+\frac{1}{2}; x-y, x, z+\frac{1}{2}; y, y-x, z+\frac{1}{2}.$

SPACE-GROUP  $C_6^3$ .—(Hexagonal Axes.)*Six* equivalent positions:

(a)  $xyz; y-x, \bar{x}, z+\frac{2}{3}; \bar{y}, x-y, z+\frac{2}{3};$   
 $\bar{x}, \bar{y}, z+\frac{2}{3}; x-y, x, z+\frac{2}{3}; y, y-x, z+\frac{2}{3}.$

SPACE-GROUP  $C_6^4$ .—(Hexagonal Axes.)*Three* equivalent positions:

(a)  $0 0 u; 0, 0, u+\frac{2}{3}; 0, 0, u+\frac{1}{3}.$

(b)  $\frac{1}{2} \frac{1}{2} u; 0, \frac{1}{2}, u+\frac{2}{3}; \frac{1}{2}, 0, u+\frac{1}{3}.$

*Six* equivalent positions:

(c)  $xyz; y-x, \bar{x}, z+\frac{2}{3}; \bar{y}, x-y, z+\frac{2}{3};$   
 $\bar{x}\bar{y}z; x-y, x, z+\frac{2}{3}; y, y-x, z+\frac{1}{3}.$

SPACE-GROUP  $C_6^5$ .—(Hexagonal Axes.)

Three equivalent positions:

- (a)  $00u$ ;  $0, 0, u+\frac{1}{2}$ ;  $0, 0, u+\frac{2}{3}$ .  
 (b)  $\frac{1}{2}\frac{1}{2}u$ ;  $0, \frac{1}{2}, u+\frac{1}{3}$ ;  $\frac{1}{2}, 0, u+\frac{2}{3}$ .

Six equivalent positions:

- (c)  $xyz$ ;  $y-x, \bar{x}, z+\frac{1}{3}$ ;  $\bar{y}, x-y, z+\frac{2}{3}$ ;  
 $\bar{x}\bar{y}z$ ;  $x-y, x, z+\frac{1}{3}$ ;  $y, y-x, z+\frac{2}{3}$ .

SPACE-GROUP  $C_6^6$ .—(Hexagonal Axes.)

Two equivalent positions:

- (a)  $00u$ ;  $0, 0, u+\frac{1}{2}$ .                      (b)  $\frac{1}{2}\frac{2}{3}u$ ;  $\frac{2}{3}\frac{1}{2}, u+\frac{1}{2}$ .

Six equivalent positions:

- (c)  $xyz$ ;                       $y-x, \bar{x}, z$ ;                       $\bar{y}, x-y, z$ ;  
 $\bar{x}, \bar{y}, z+\frac{1}{2}$ ;                       $x-y, x, z+\frac{1}{2}$ ;                       $y, y-x, z+\frac{1}{2}$ .

D. HEMIMORPHIC HEMIHEDRY.

SPACE-GROUP  $C_{6v}^1$ .—(Hexagonal Axes.)

One equivalent position:

- (a)  $00u$ .

Two equivalent positions:

- (b)  $\frac{1}{2}\frac{2}{3}u$ ;  $\frac{2}{3}\frac{1}{2}u$ .

Three equivalent positions:

- (c)  $\frac{1}{2}\frac{1}{2}u$ ;  $0\frac{1}{2}u$ ;  $\frac{1}{2}0u$ .

Six equivalent positions:

- (d)  $uu v$ ;  $0\bar{u} v$ ;  $\bar{u}\bar{u} v$ ;  $\bar{u}\bar{u} v$ ;  $0u v$ ;  $u0 v$ .  
 (e)  $u\bar{u} v$ ;  $2\bar{u}, \bar{u}, v$ ;  $u, 2u, v$ ;  $\bar{u}u v$ ;  $2u, u, v$ ;  $\bar{u}, 2\bar{u}, v$ .

Twelve equivalent positions:

- (f)  $xyz$ ;                       $y-x, \bar{x}, z$ ;                       $\bar{y}, x-y, z$ ;  
 $\bar{x}\bar{y}z$ ;                       $x-y, x, z$ ;                       $y, y-x, z$ ;  
 $\bar{x}, y-x, z$ ;                       $yxz$ ;                       $x-y, \bar{y}, z$ ;  
 $x, x-y, z$ ;                       $\bar{y}\bar{x}z$ ;                       $y-x, y, z$ .

SPACE-GROUP  $C_{6v}^2$ .—(Hexagonal Axes.)

Two equivalent positions:

- (a)  $00u$ ;  $0, 0, u+\frac{1}{2}$ .

Four equivalent positions:

- (b)  $\frac{1}{2}\frac{2}{3}u$ ;  $\frac{2}{3}\frac{1}{2}u$ ;  $\frac{2}{3}, \frac{1}{2}, u+\frac{1}{2}$ ;  $\frac{1}{2}, \frac{2}{3}, u+\frac{1}{2}$ .



SPACE-GROUP  $C_{6v}^2$  (continued).*Six equivalent positions:*

$$(c) \frac{1}{2} \frac{1}{2} u; \quad 0 \frac{1}{2} u; \quad \frac{1}{2} 0 u; \\ \frac{1}{2}, \frac{1}{2}, u + \frac{1}{2}; \quad 0, \frac{1}{2}, u + \frac{1}{2}; \quad \frac{1}{2}, 0, u + \frac{1}{2}.$$

*Twelve equivalent positions:*

$$(d) \begin{array}{lll} xyz; & y-x, \bar{x}, z; & \bar{y}, x-y, z; \\ \bar{x}\bar{y}z; & x-y, x, z; & y, y-x, z; \\ \bar{x}, y-x, z + \frac{1}{2}; & y, x, z + \frac{1}{2}; & x-y, \bar{y}, z + \frac{1}{2}; \\ x, x-y, z + \frac{1}{2}; & \bar{y}, \bar{x}, z + \frac{1}{2}; & y-x, y, z + \frac{1}{2}. \end{array}$$

SPACE-GROUP  $C_{6v}^3$ .—(Hexagonal Axes.)*Two equivalent positions:*

$$(a) 00u; \quad 0, 0, u + \frac{1}{2}.$$

*Four equivalent positions:*

$$(b) \frac{1}{2} \frac{2}{3} u; \quad \frac{2}{3}, \frac{1}{3}, u + \frac{1}{2}; \quad \frac{2}{3} \frac{1}{3} u; \quad \frac{1}{3}, \frac{2}{3}, u + \frac{1}{2}.$$

*Six equivalent positions:*

$$(c) \begin{array}{lll} uuv; & 0\bar{u}v; & \bar{u}0v; \\ \bar{u}, \bar{u}, v + \frac{1}{2}; & 0, u, v + \frac{1}{2}; & u, 0, v + \frac{1}{2}. \end{array}$$

*Twelve equivalent positions:*

$$(d) \begin{array}{lll} xyz; & y-x, \bar{x}, z; & \bar{y}, x-y, z; \\ \bar{x}, \bar{y}, z + \frac{1}{2}; & x-y, x, z + \frac{1}{2}; & y, y-x, z + \frac{1}{2}; \\ \bar{x}, y-x, z; & yxz; & x-y, \bar{y}, z; \\ x, x-y, z + \frac{1}{2}; & \bar{y}, \bar{x}, z + \frac{1}{2}; & y-x, y, z + \frac{1}{2}. \end{array}$$

SPACE-GROUP  $C_{6v}^4$ .—(Hexagonal Axes.)*Two equivalent positions:*

$$(a) 00u; \quad 0, 0, u + \frac{1}{2}. \quad (b) \frac{1}{2} \frac{2}{3} u; \quad \frac{2}{3}, \frac{1}{3}, u + \frac{1}{2}.$$

*Six equivalent positions:*

$$(c) \begin{array}{lll} u\bar{u}v; & 2\bar{u}, \bar{u}, v; & u, 2u, v; \\ \bar{u}, u, v + \frac{1}{2}; & 2u, u, v + \frac{1}{2}; & \bar{u}, 2\bar{u}, v + \frac{1}{2}. \end{array}$$

*Twelve equivalent positions:*

$$(d) \begin{array}{lll} xyz; & y-x, \bar{x}, z; & \bar{y}, x-y, z; \\ \bar{x}, \bar{y}, z + \frac{1}{2}; & x-y, x, z + \frac{1}{2}; & y, y-x, z + \frac{1}{2}; \\ \bar{x}, y-x, z + \frac{1}{2}; & y, x, z + \frac{1}{2}; & x-y, \bar{y}, z + \frac{1}{2}; \\ x, x-y, z; & \bar{y}\bar{x}z; & y-x, y, z. \end{array}$$

## E. PARAMORPHIC HEMIHEDRY.

SPACE-GROUP  $C_{6h}^1$ .—(Hexagonal Axes.)*One equivalent position:*

$$(a) 000. \quad (b) 00\frac{1}{2}.$$

SPACE-GROUP  $C_{6h}^1$  (continued).

Two equivalent positions:

- (c)  $\frac{1}{3} \frac{2}{3} 0$ ;  $\frac{2}{3} \frac{1}{3} 0$ .      (e)  $0 0 u$ ;  $0 0 \bar{u}$ .  
 (d)  $\frac{1}{3} \frac{2}{3} \frac{1}{3}$ ;  $\frac{2}{3} \frac{1}{3} \frac{1}{3}$ .

Three equivalent positions:

- (f)  $\frac{1}{3} \frac{1}{3} 0$ ;  $0 \frac{1}{3} 0$ ;  $\frac{1}{3} 0 0$ .      (g)  $\frac{1}{3} \frac{1}{3} \frac{1}{3}$ ;  $0 \frac{1}{3} \frac{1}{3}$ ;  $\frac{1}{3} 0 \frac{1}{3}$ .

Four equivalent positions:

- (h)  $\frac{1}{3} \frac{2}{3} u$ ;  $\frac{2}{3} \frac{1}{3} u$ ;  $\frac{1}{3} \frac{2}{3} \bar{u}$ ;  $\frac{2}{3} \frac{1}{3} \bar{u}$ .

Six equivalent positions:

- (i)  $\frac{1}{3} \frac{1}{3} u$ ;  $0 \frac{1}{3} u$ ;  $\frac{1}{3} 0 u$ ;  $\frac{1}{3} \frac{1}{3} \bar{u}$ ;  $0 \frac{1}{3} \bar{u}$ ;  $\frac{1}{3} 0 \bar{u}$ .  
 (j)  $u v 0$ ;  $v - u, \bar{u}, 0$ ;  $\bar{v}, u - v, 0$ ;  
 $\bar{u} \bar{v} 0$ ;  $u - v, u, 0$ ;  $v, v - u, 0$ .  
 (k)  $u v \frac{1}{3}$ ;  $v - u, \bar{u}, \frac{1}{3}$ ;  $\bar{v}, u - v, \frac{1}{3}$ ;  
 $\bar{u} \bar{v} \frac{1}{3}$ ;  $u - v, u, \frac{1}{3}$ ;  $v, v - u, \frac{1}{3}$ .

Twelve equivalent positions:

- (l)  $xyz$ ;  $y - x, \bar{x}, z$ ;  $\bar{y}, x - y, z$ ;  
 $\bar{x}\bar{y}z$ ;  $x - y, x, z$ ;  $y, y - x, z$ ;  
 $xy\bar{z}$ ;  $y - x, \bar{x}, \bar{z}$ ;  $\bar{y}, x - y, \bar{z}$ ;  
 $\bar{x}\bar{y}\bar{z}$ ;  $x - y, x, \bar{z}$ ;  $y, y - x, \bar{z}$ .

SPACE-GROUP  $C_{6h}^2$ .—(Hexagonal Axes.)

Two equivalent positions:

- (a)  $0 0 0$ ;  $0 0 \frac{1}{2}$ .      (c)  $\frac{1}{3} \frac{2}{3} 0$ ;  $\frac{2}{3} \frac{1}{3} \frac{1}{2}$ .  
 (b)  $0 0 \frac{1}{3}$ ;  $0 0 \frac{2}{3}$ .      (d)  $\frac{1}{3} \frac{2}{3} \frac{1}{2}$ ;  $\frac{2}{3} \frac{1}{3} 0$ .

Four equivalent positions:

- (e)  $0 0 u$ ;  $0 0 \bar{u}$ ;  $0, 0, \frac{1}{2} - u$ ;  $0, 0, u + \frac{1}{2}$ .  
 (f)  $\frac{1}{3} \frac{2}{3} u$ ;  $\frac{1}{3} \frac{2}{3} \bar{u}$ ;  $\frac{2}{3}, \frac{1}{3}, \frac{1}{2} - u$ ;  $\frac{2}{3}, \frac{1}{3}, u + \frac{1}{2}$ .

Six equivalent positions:

- (g)  $\frac{1}{3} \frac{1}{3} \frac{1}{2}$ ;  $0 \frac{1}{3} \frac{1}{2}$ ;  $\frac{1}{3} 0 \frac{1}{2}$ ;  $\frac{1}{3} \frac{1}{3} \frac{1}{2}$ ;  $0 \frac{1}{3} \frac{1}{2}$ ;  $\frac{1}{3} 0 \frac{1}{2}$ .  
 (h)  $u v 0$ ;  $v - u, \bar{u}, 0$ ;  $\bar{v}, u - v, 0$ ;  
 $\bar{u} \bar{v} \frac{1}{2}$ ;  $u - v, u, \frac{1}{2}$ ;  $v, v - u, \frac{1}{2}$ .

Twelve equivalent positions:

- (i)  $xyz$ ;       $y - x, \bar{x}, z$ ;       $\bar{y}, x - y, z$ ;  
 $\bar{x}, \bar{y}, z + \frac{1}{2}$ ;  $x - y, x, z + \frac{1}{2}$ ;  $y, y - x, z + \frac{1}{2}$ ;  
 $xy\bar{z}$ ;       $y - x, \bar{x}, \bar{z}$ ;       $\bar{y}, x - y, \bar{z}$ ;  
 $\bar{x}, \bar{y}, \frac{1}{2} - z$ ;  $x - y, x, \frac{1}{2} - z$ ;  $y, y - x, \frac{1}{2} - z$ .

F. ENANTIOMORPHIC HEMIHEDRY.

SPACE-GROUP  $D_6^1$ .—(Hexagonal Axes.)

One equivalent position:

- (a)  $0 0 0$ .      (b)  $0 0 \frac{1}{2}$ .

SPACE-GROUP  $D_6^1$  (continued).

Two equivalent positions:

$$(c) \frac{1}{2} \frac{2}{3} 0; \frac{2}{3} \frac{1}{3} 0. \quad (e) 0 0 u; 0 0 \bar{u}.$$

$$(d) \frac{1}{3} \frac{2}{3} \frac{1}{3}; \frac{2}{3} \frac{1}{3} \frac{1}{3}.$$

Three equivalent positions:

$$(f) \frac{1}{2} \frac{1}{2} 0; 0 \frac{1}{2} 0; \frac{1}{2} 0 0. \quad (g) \frac{1}{2} \frac{1}{2} \frac{1}{2}; 0 \frac{1}{2} \frac{1}{2}; \frac{1}{2} 0 \frac{1}{2}.$$

Four equivalent positions:

$$(h) \frac{1}{2} \frac{2}{3} u; \frac{2}{3} \frac{1}{3} u; \frac{2}{3} \frac{1}{3} \bar{u}; \frac{1}{2} \frac{2}{3} \bar{u}.$$

Six equivalent positions:

$$(i) \frac{1}{2} \frac{1}{2} u; 0 \frac{1}{2} u; \frac{1}{2} 0 u; \frac{1}{2} \frac{1}{2} \bar{u}; 0 \frac{1}{2} \bar{u}; \frac{1}{2} 0 \bar{u}.$$

$$(j) u u 0; 0 \bar{u} 0; \bar{u} 0 0; \bar{u} \bar{u} 0; 0 u 0; u 0 0.$$

$$(k) u u \frac{1}{2}; 0 \bar{u} \frac{1}{2}; \bar{u} 0 \frac{1}{2}; \bar{u} \bar{u} \frac{1}{2}; 0 u \frac{1}{2}; u 0 \frac{1}{2}.$$

$$(l) u \bar{u} 0; 2\bar{u}, \bar{u}, 0; u, 2u, 0; \bar{u} u 0; 2u, u, 0; \bar{u}, 2\bar{u}, 0.$$

$$(m) u \bar{u} \frac{1}{2}; 2\bar{u}, \bar{u}, \frac{1}{2}; u, 2u, \frac{1}{2}; \bar{u} u \frac{1}{2}; 2u, u, \frac{1}{2}; \bar{u}, 2\bar{u}, \frac{1}{2}.$$

Twelve equivalent positions:

$$(n) xyz; \quad y-x, \bar{x}, z; \quad \bar{y}, x-y, z;$$

$$\bar{x}\bar{y}z; \quad x-y, x, z; \quad y, y-x, z;$$

$$\bar{x}, y-x, \bar{z}; \quad yx\bar{z}; \quad x-y, \bar{y}, \bar{z};$$

$$x, x-y, \bar{z}; \quad \bar{y}\bar{x}\bar{z}; \quad y-x, y, \bar{z}.$$

SPACE-GROUP  $D_6^2$ .—(Hexagonal Axes.)

Six equivalent positions:

$$(a) 0 u 0; u 0 \frac{1}{2}; \bar{u} \bar{u} \frac{1}{2}; 0 \bar{u} \frac{1}{2}; \bar{u} 0 \frac{1}{2}; u u \frac{1}{2}.$$

$$(b) u \bar{u} \frac{5}{12}; 2\bar{u}, \bar{u}, \frac{1}{2}; u, 2u, \frac{1}{12}; \bar{u} u \frac{11}{12}; 2u, u, \frac{1}{2}; \bar{u}, 2\bar{u}, \frac{7}{12}.$$

Twelve equivalent positions:

$$(c) xyz; \quad y-x, \bar{x}, z+\frac{1}{2}; \quad \bar{y}, x-y, z+\frac{2}{3};$$

$$\bar{x}, \bar{y}, z+\frac{1}{2}; \quad x-y, x, z+\frac{2}{3}; \quad y, y-x, z+\frac{1}{2};$$

$$\bar{x}, y-x, \bar{z}; \quad x-y, \bar{y}, \frac{2}{3}-z; \quad y, x, \frac{1}{2}-z;$$

$$x, x-y, \frac{1}{2}-z; \quad y-x, y, \frac{1}{2}-z; \quad \bar{y}, \bar{x}, \frac{2}{3}-z.$$

SPACE-GROUP  $D_6^3$ .—(Hexagonal Axes.)

Six equivalent positions:

$$(a) 0 u 0; u 0 \frac{2}{3}; \bar{u} \bar{u} \frac{1}{3}; 0 \bar{u} \frac{1}{3}; \bar{u} 0 \frac{1}{3}; u u \frac{2}{3}.$$

$$(b) u \bar{u} \frac{1}{12}; 2\bar{u}, \bar{u}, \frac{2}{3}; u, 2u, \frac{5}{12}; \bar{u} u \frac{7}{12}; 2u, u, \frac{1}{2}; \bar{u}, 2\bar{u}, \frac{11}{12}.$$

Twelve equivalent positions:

$$(c) xyz; \quad y-x, \bar{x}, z+\frac{2}{3}; \quad \bar{y}, x-y, z+\frac{1}{3};$$

$$\bar{x}, \bar{y}, z+\frac{1}{3}; \quad x-y, x, z+\frac{1}{3}; \quad y, y-x, z+\frac{2}{3};$$

$$\bar{x}, y-x, \bar{z}; \quad x-y, \bar{y}, \frac{1}{3}-z; \quad y, x, \frac{2}{3}-z;$$

$$x, x-y, \frac{1}{3}-z; \quad y-x, y, \frac{2}{3}-z; \quad \bar{y}, \bar{x}, \frac{1}{3}-z.$$

SPACE-GROUP  $D_6^4$ .—(Hexagonal Axes.)

Three equivalent positions:

- (a)  $000$ ;  $00\frac{2}{3}$ ;  $00\frac{1}{3}$ .      (c)  $\frac{1}{2}\frac{1}{2}\frac{1}{2}$ ;  $0\frac{1}{2}0$ ;  $\frac{1}{2}0\frac{2}{3}$ .  
 (b)  $00\frac{1}{3}$ ;  $00\frac{2}{3}$ ;  $00\frac{1}{6}$ .      (d)  $\frac{1}{2}\frac{1}{2}\frac{2}{3}$ ;  $0\frac{1}{2}\frac{1}{3}$ ;  $\frac{1}{2}0\frac{1}{3}$ .

Six equivalent positions:

- (e)  $00u$ ;  $0, 0, u+\frac{2}{3}$ ;  $0, 0, u+\frac{1}{3}$ ;  
 $00\bar{u}$ ;  $0, 0, \frac{2}{3}-u$ ;  $0, 0, \frac{1}{3}-u$ .  
 (f)  $\frac{1}{2}\frac{1}{2}u$ ;  $0, \frac{1}{2}, u+\frac{2}{3}$ ;  $\frac{1}{2}, 0, u+\frac{1}{3}$ ;  
 $\frac{1}{2}0\bar{u}$ ;  $0, \frac{1}{2}, \frac{2}{3}-u$ ;  $\frac{1}{2}, \frac{1}{2}, \frac{1}{3}-u$ .  
 (g)  $uu\frac{1}{3}$ ;  $0\bar{u}0$ ;  $\bar{u}0\frac{2}{3}$ ;  $\bar{u}\bar{u}\frac{1}{3}$ ;  $0u0$ ;  $u0\frac{2}{3}$ .  
 (h)  $uu\frac{2}{3}$ ;  $0\bar{u}\frac{1}{3}$ ;  $\bar{u}0\frac{1}{3}$ ;  $\bar{u}\bar{u}\frac{2}{3}$ ;  $0u\frac{1}{3}$ ;  $u0\frac{1}{3}$ .  
 (i)  $u\bar{u}\frac{1}{3}$ ;  $2\bar{u}, \bar{u}, 0$ ;  $u, 2u, \frac{2}{3}$ ;  $\bar{u}u\frac{1}{3}$ ;  $2u, u, 0$ ;  $\bar{u}, 2\bar{u}, \frac{2}{3}$ .  
 (j)  $u\bar{u}\frac{2}{3}$ ;  $2\bar{u}, \bar{u}, \frac{1}{3}$ ;  $u, 2u, \frac{1}{3}$ ;  $\bar{u}u\frac{2}{3}$ ;  $2u, u, \frac{1}{3}$ ;  $\bar{u}, 2\bar{u}, \frac{1}{3}$ .

Twelve equivalent positions:

- (k)  $xyz$ ;       $y-x, \bar{x}, z+\frac{2}{3}$ ;  $\bar{y}, x-y, z+\frac{1}{3}$ ;  
 $\bar{x}\bar{y}z$ ;       $x-y, x, z+\frac{2}{3}$ ;  $y, y-x, z+\frac{1}{3}$ ;  
 $\bar{x}, y-x, \bar{z}$ ;  $x-y, \bar{y}, \frac{1}{3}-z$ ;  $y, x, \frac{2}{3}-z$ ;  
 $x, x-y, \bar{z}$ ;  $y-x, y, \frac{1}{3}-z$ ;  $\bar{y}, \bar{x}, \frac{2}{3}-z$ .

SPACE-GROUP  $D_6^5$ .—(Hexagonal Axes.)

Three equivalent positions:

- (a)  $000$ ;  $00\frac{1}{3}$ ;  $00\frac{2}{3}$ .      (c)  $\frac{1}{2}\frac{1}{2}\frac{1}{3}$ ;  $0\frac{1}{2}\frac{1}{3}$ ;  $\frac{1}{2}0\frac{2}{3}$ .  
 (b)  $00\frac{2}{3}$ ;  $00\frac{1}{3}$ ;  $00\frac{1}{6}$ .      (d)  $\frac{1}{2}\frac{1}{2}\frac{2}{3}$ ;  $0\frac{1}{2}0$ ;  $\frac{1}{2}0\frac{1}{3}$ .

Six equivalent positions:

- (e)  $00u$ ;  $0, 0, u+\frac{1}{3}$ ;  $0, 0, u+\frac{2}{3}$ ;  
 $00\bar{u}$ ;  $0, 0, \frac{2}{3}-u$ ;  $0, 0, \frac{1}{3}-u$ .  
 (f)  $\frac{1}{2}\frac{1}{2}u$ ;  $0, \frac{1}{2}, u+\frac{1}{3}$ ;  $\frac{1}{2}, 0, u+\frac{2}{3}$ ;  
 $\frac{1}{2}0\bar{u}$ ;  $0, \frac{1}{2}, \frac{2}{3}-u$ ;  $\frac{1}{2}, \frac{1}{2}, \frac{1}{3}-u$ .  
 (g)  $uu\frac{1}{3}$ ;  $0\bar{u}\frac{2}{3}$ ;  $\bar{u}0\frac{2}{3}$ ;  $\bar{u}\bar{u}\frac{1}{3}$ ;  $0u\frac{1}{3}$ ;  $u0\frac{2}{3}$ .  
 (h)  $uu\frac{2}{3}$ ;  $0\bar{u}0$ ;  $\bar{u}0\frac{1}{3}$ ;  $\bar{u}\bar{u}\frac{2}{3}$ ;  $0u0$ ;  $u0\frac{1}{3}$ .  
 (i)  $u\bar{u}\frac{1}{3}$ ;  $2\bar{u}, \bar{u}, \frac{1}{3}$ ;  $u, 2u, \frac{2}{3}$ ;  $\bar{u}u\frac{1}{3}$ ;  $2u, u, \frac{1}{3}$ ;  $\bar{u}, 2\bar{u}, \frac{2}{3}$ .  
 (j)  $u\bar{u}\frac{2}{3}$ ;  $2\bar{u}, \bar{u}, 0$ ;  $u, 2u, \frac{1}{3}$ ;  $\bar{u}u\frac{2}{3}$ ;  $2u, u, 0$ ;  $\bar{u}, 2\bar{u}, \frac{1}{3}$ .

Twelve equivalent positions:

- (k)  $xyz$ ;       $y-x, \bar{x}, z+\frac{1}{3}$ ;  $\bar{y}, x-y, z+\frac{2}{3}$ ;  
 $\bar{x}\bar{y}z$ ;       $x-y, x, z+\frac{1}{3}$ ;  $y, y-x, z+\frac{2}{3}$ ;  
 $\bar{x}, y-x, \bar{z}$ ;  $x-y, \bar{y}, \frac{2}{3}-z$ ;  $y, x, \frac{1}{3}-z$ ;  
 $x, x-y, \bar{z}$ ;  $y-x, y, \frac{2}{3}-z$ ;  $\bar{y}, \bar{x}, \frac{1}{3}-z$ .

SPACE-GROUP  $D_6^6$ .—(Hexagonal Axes.)

Two equivalent positions:

- (a)  $000$ ;  $00\frac{1}{2}$ .      (c)  $\frac{1}{2}\frac{2}{3}\frac{1}{3}$ ;  $\frac{2}{3}\frac{1}{3}\frac{2}{3}$ .  
 (b)  $00\frac{1}{2}$ ;  $00\frac{1}{3}$ .      (d)  $\frac{1}{2}\frac{2}{3}\frac{2}{3}$ ;  $\frac{2}{3}\frac{1}{3}\frac{1}{3}$ .

SPACE-GROUP  $D_6^6$  (continued).

Four equivalent positions:

- (e)  $00u$ ;  $00\bar{u}$ ;  $0, 0, u+\frac{1}{2}$ ;  $0, 0, \frac{1}{2}-u$ .  
 (f)  $\frac{1}{2}\frac{2}{3}u$ ;  $\frac{2}{3}\frac{1}{3}\bar{u}$ ;  $\frac{2}{3}, \frac{1}{3}, u+\frac{1}{2}$ ;  $\frac{1}{3}, \frac{2}{3}, \frac{1}{2}-u$ .

Six equivalent positions:

- (g)  $uu0$ ;  $0\bar{u}0$ ;  $\bar{u}00$ ;  $\bar{u}\bar{u}\frac{1}{2}$ ;  $0u\frac{1}{2}$ ;  $u0\frac{1}{2}$ .  
 (h)  $u\bar{u}\frac{1}{2}$ ;  $2\bar{u}, \bar{u}, \frac{1}{2}$ ;  $u, 2u, \frac{1}{2}$ ;  $\bar{u}u\frac{2}{3}$ ;  $2u, u, \frac{2}{3}$ ;  $\bar{u}, 2\bar{u}, \frac{2}{3}$ .

Twelve equivalent positions:

- (i)  $xyz$ ;  $y-x, \bar{x}, z$ ;  $\bar{y}, x-y, z$ ;  
 $\bar{x}, \bar{y}, z+\frac{1}{2}$ ;  $x-y, x, z+\frac{1}{2}$ ;  $y, y-x, z+\frac{1}{2}$ ;  
 $\bar{x}, y-x, \bar{z}$ ;  $x-y, \bar{y}, \bar{z}$ ;  $yx\bar{z}$ ;  
 $x, x-y, \frac{1}{2}-z$ ;  $y-x, y, \frac{1}{2}-z$ ;  $\bar{y}, \bar{x}, \frac{1}{2}-z$ .

## G. HOLOHEDRY.

SPACE-GROUP  $D_{6h}^1$ —(Hexagonal Axes.)

One equivalent position:

- (a)  $000$ . (b)  $00\frac{1}{2}$ .

Two equivalent positions:

- (c)  $\frac{1}{2}\frac{2}{3}0$ ;  $\frac{2}{3}\frac{1}{3}0$ . (e)  $00u$ ;  $00\bar{u}$ .  
 (d)  $\frac{1}{2}\frac{2}{3}\frac{1}{2}$ ;  $\frac{2}{3}\frac{1}{3}\frac{1}{2}$ .

Three equivalent positions:

- (f)  $\frac{1}{2}\frac{1}{2}0$ ;  $0\frac{1}{2}0$ ;  $\frac{1}{2}00$ . (g)  $\frac{1}{2}\frac{1}{2}\frac{1}{2}$ ;  $0\frac{1}{2}\frac{1}{2}$ ;  $\frac{1}{2}0\frac{1}{2}$ .

Four equivalent positions:

- (h)  $\frac{1}{2}\frac{2}{3}u$ ;  $\frac{2}{3}\frac{1}{3}u$ ;  $\frac{2}{3}\frac{1}{3}\bar{u}$ ;  $\frac{1}{2}\frac{2}{3}\bar{u}$ .

Six equivalent positions:

- (i)  $\frac{1}{2}\frac{1}{2}u$ ;  $0\frac{1}{2}u$ ;  $\frac{1}{2}0u$ ;  $\frac{1}{2}\frac{1}{2}\bar{u}$ ;  $0\frac{1}{2}\bar{u}$ ;  $\frac{1}{2}0\bar{u}$ .  
 (j)  $uu0$ ;  $0\bar{u}0$ ;  $\bar{u}00$ ;  $\bar{u}\bar{u}0$ ;  $0u0$ ;  $u00$ .  
 (k)  $uu\frac{1}{2}$ ;  $0\bar{u}\frac{1}{2}$ ;  $\bar{u}0\frac{1}{2}$ ;  $\bar{u}\bar{u}\frac{1}{2}$ ;  $0u\frac{1}{2}$ ;  $u0\frac{1}{2}$ .  
 (l)  $u\bar{u}0$ ;  $2\bar{u}, \bar{u}, 0$ ;  $u, 2u, 0$ ;  $\bar{u}u0$ ;  $2u, u, 0$ ;  $\bar{u}, 2\bar{u}, 0$ .  
 (m)  $u\bar{u}\frac{1}{2}$ ;  $2\bar{u}, \bar{u}, \frac{1}{2}$ ;  $u, 2u, \frac{1}{2}$ ;  $\bar{u}u\frac{1}{2}$ ;  $2u, u, \frac{1}{2}$ ;  $\bar{u}, 2\bar{u}, \frac{1}{2}$ .

Twelve equivalent positions:

- (n)  $uu v$ ;  $0\bar{u} v$ ;  $\bar{u}0 v$ ;  $\bar{u}\bar{u} v$ ;  $0u v$ ;  $u0 v$ ;  
 $u u \bar{v}$ ;  $0\bar{u} \bar{v}$ ;  $\bar{u}0 \bar{v}$ ;  $\bar{u}\bar{u} \bar{v}$ ;  $0u \bar{v}$ ;  $u0 \bar{v}$ .  
 (o)  $u\bar{u} v$ ;  $2\bar{u}, \bar{u}, v$ ;  $u, 2u, v$ ;  $\bar{u}u v$ ;  $2u, u, v$ ;  $\bar{u}, 2\bar{u}, v$ ;  
 $u\bar{u} \bar{v}$ ;  $2\bar{u}, \bar{u}, \bar{v}$ ;  $u, 2u, \bar{v}$ ;  $\bar{u}u \bar{v}$ ;  $2u, u, \bar{v}$ ;  $\bar{u}, 2\bar{u}, \bar{v}$ .  
 (p)  $u v 0$ ;  $v-u, \bar{u}, 0$ ;  $\bar{v}, u-v, 0$ ;  
 $\bar{u} \bar{v} 0$ ;  $u-v, u, 0$ ;  $v, v-u, 0$ ;  
 $\bar{u}, v-u, 0$ ;  $u-v, \bar{v}, 0$ ;  $v u 0$ ;  
 $u, u-v, 0$ ;  $v-u, v, 0$ ;  $\bar{v} \bar{u} 0$ .

SPACE-GROUP  $D_{6h}^1$  (continued).

- (q)  $u v \frac{1}{2}$ ;  $v-u, \bar{u}, \frac{1}{2}$ ;  $\bar{v}, u-v, \frac{1}{2}$ ;  
 $\bar{u} \bar{v} \frac{1}{2}$ ;  $u-v, u, \frac{1}{2}$ ;  $v, v-u, \frac{1}{2}$ ;  
 $\bar{u}, v-u, \frac{1}{2}$ ;  $u-v, \bar{v}, \frac{1}{2}$ ;  $v u \frac{1}{2}$ ;  
 $u, u-v, \frac{1}{2}$ ;  $v-u, v, \frac{1}{2}$ ;  $\bar{v} \bar{u} \frac{1}{2}$ .

Twenty-four equivalent positions:

- (r)  $xyz$ ;  $y-x, \bar{x}, z$ ;  $\bar{y}, x-y, z$ ;  
 $\bar{x}\bar{y}z$ ;  $x-y, x, z$ ;  $y, y-x, z$ ;  
 $\bar{x}, y-x, \bar{z}$ ;  $x-y, \bar{y}, \bar{z}$ ;  $yx\bar{z}$ ;  
 $x, x-y, \bar{z}$ ;  $y-x, y, \bar{z}$ ;  $\bar{y}\bar{x}\bar{z}$ ;  
 $xy\bar{z}$ ;  $y-x, \bar{x}, \bar{z}$ ;  $\bar{y}, x-y, \bar{z}$ ;  
 $\bar{x}\bar{y}\bar{z}$ ;  $x-y, x, \bar{z}$ ;  $y, y-x, \bar{z}$ ;  
 $\bar{x}, y-x, z$ ;  $x-y, \bar{y}, z$ ;  $yxz$ ;  
 $x, x-y, z$ ;  $y-x, y, z$ ;  $\bar{y}\bar{x}z$ .

SPACE-GROUP  $D_{6h}^2$ .—(Hexagonal Axes.)

Two equivalent positions:

- (a)  $000$ ;  $00\frac{1}{2}$ . (b)  $00\frac{1}{2}$ ;  $00\frac{3}{2}$ .

Four equivalent positions:

- (c)  $\frac{1}{2}\frac{1}{2}0$ ;  $\frac{2}{3}\frac{1}{3}0$ ;  $\frac{1}{3}\frac{2}{3}\frac{1}{2}$ ;  $\frac{2}{3}\frac{1}{3}\frac{1}{2}$ .  
 (d)  $\frac{1}{2}\frac{1}{2}\frac{1}{2}$ ;  $\frac{2}{3}\frac{1}{3}\frac{1}{2}$ ;  $\frac{1}{3}\frac{2}{3}\frac{2}{3}$ ;  $\frac{1}{3}\frac{2}{3}\frac{1}{3}$ .  
 (e)  $00u$ ;  $00\bar{u}$ ;  $0, 0, \frac{1}{2}-u$ ;  $0, 0, u+\frac{1}{2}$ .

Six equivalent positions:

- (f)  $\frac{1}{2}\frac{1}{2}0$ ;  $0\frac{1}{2}0$ ;  $\frac{1}{2}00$ ;  $\frac{1}{2}\frac{1}{2}\frac{1}{2}$ ;  $0\frac{1}{2}\frac{1}{2}$ ;  $\frac{1}{2}0\frac{1}{2}$ .  
 (g)  $\frac{1}{2}\frac{1}{2}\frac{1}{2}$ ;  $0\frac{1}{2}\frac{1}{2}$ ;  $\frac{1}{2}0\frac{1}{2}$ ;  $\frac{1}{2}\frac{1}{2}\frac{2}{3}$ ;  $0\frac{1}{2}\frac{2}{3}$ ;  $\frac{1}{2}0\frac{2}{3}$ .

Eight equivalent positions:

- (h)  $\frac{1}{2}\frac{2}{3}u$ ;  $\frac{2}{3}\frac{1}{3}u$ ;  $\frac{2}{3}, \frac{1}{3}, u+\frac{1}{2}$ ;  $\frac{1}{3}, \frac{2}{3}, u+\frac{1}{2}$ ;  
 $\frac{1}{2}\frac{2}{3}\bar{u}$ ;  $\frac{2}{3}\frac{1}{3}\bar{u}$ ;  $\frac{2}{3}, \frac{1}{3}, \frac{1}{2}-u$ ;  $\frac{1}{3}, \frac{2}{3}, \frac{1}{2}-u$ .

Twelve equivalent positions:

- (i)  $\frac{1}{2}\frac{1}{2}u$ ;  $0\frac{1}{2}u$ ;  $\frac{1}{2}0u$ ;  
 $\frac{1}{2}\frac{1}{2}\bar{u}$ ;  $0\frac{1}{2}\bar{u}$ ;  $\frac{1}{2}0\bar{u}$ ;  
 $\frac{1}{2}, \frac{1}{2}, \frac{1}{2}-u$ ;  $0, \frac{1}{2}, \frac{1}{2}-u$ ;  $\frac{1}{2}, 0, \frac{1}{2}-u$ ;  
 $\frac{1}{2}, \frac{1}{2}, u+\frac{1}{2}$ ;  $0, \frac{1}{2}, u+\frac{1}{2}$ ;  $\frac{1}{2}, 0, u+\frac{1}{2}$ .  
 (j)  $uu0$ ;  $0\bar{u}0$ ;  $\bar{u}00$ ;  $\bar{u}\bar{u}0$ ;  $0u0$ ;  $u00$ ;  
 $uu\frac{1}{2}$ ;  $0\bar{u}\frac{1}{2}$ ;  $\bar{u}0\frac{1}{2}$ ;  $\bar{u}\bar{u}\frac{1}{2}$ ;  $0u\frac{1}{2}$ ;  $u0\frac{1}{2}$ .  
 (k)  $u\bar{u}0$ ;  $2\bar{u}, \bar{u}, 0$ ;  $u, 2u, 0$ ;  $\bar{u}\bar{u}0$ ;  $2u, u, 0$ ;  $\bar{u}, 2\bar{u}, 0$ ;  
 $u\bar{u}\frac{1}{2}$ ;  $2\bar{u}, \bar{u}, \frac{1}{2}$ ;  $u, 2u, \frac{1}{2}$ ;  $\bar{u}\bar{u}\frac{1}{2}$ ;  $2u, u, \frac{1}{2}$ ;  $\bar{u}, 2\bar{u}, \frac{1}{2}$ .  
 (l)  $uv\frac{1}{2}$ ;  $v-u, \bar{u}, \frac{1}{2}$ ;  $\bar{v}, u-v, \frac{1}{2}$ ;  
 $\bar{u}\bar{v}\frac{1}{2}$ ;  $u-v, v, \frac{1}{2}$ ;  $v, v-u, \frac{1}{2}$ ;  
 $vu\frac{2}{3}$ ;  $\bar{u}, v-u, \frac{2}{3}$ ;  $u-v, \bar{v}, \frac{2}{3}$ ;  
 $\bar{v}\bar{u}\frac{2}{3}$ ;  $u, u-v, \frac{2}{3}$ ;  $v-u, v, \frac{2}{3}$ .

## TABLES.

The following tables provide a summary of the number and kinds of the different arrangements to be obtained from each of the space-groups. In these tabulations the symbol 1 (0), for instance, signifies one arrangement (a special case) having no variable parameters; similarly the symbol 3 (2) would mean three arrangements having two variable parameters each.

TABLE 3.—TRICLINIC SYSTEM.

Space-Group.	Number of equivalent positions.	
	1	2
<i>A. Hemihedry:</i>		
$C_1$ .....	1 (3)	....
<i>B. Holohedry:</i>		
$C_1^i$ .....	8 (0)	1 (3)

TABLE 4.—MONOCLINIC SYSTEM.

Space-Group.	Number of equivalent positions.			
	1	2	4	8
<i>A. Hemihedry:</i>				
$C_2^i$ .....	2 (2)	1 (3)	....	....
$C_2^i$ .....	....	1 (3)	....	....
$C_2^i$ .....	....	1 (2)	1 (3)	....
$C_2^i$ .....	....	....	1 (3)	....
<i>B. Hemimorphic hemihedry:</i>				
$C_2^i$ .....	4 (1)	1 (3)	....	....
$C_2^i$ .....	....	1 (3)	....	....
$C_2^i$ .....	....	2 (1)	1 (3)	....
<i>C. Holohedry:</i>				
$C_{2h}^i$ .....	8 (0)	4 (1); 2 (2)	1 (3)	....
$C_{2h}^i$ .....	....	4 (0); 1 (2)	1 (3)	....
$C_{2h}^i$ .....	....	4 (0)	2 (0) 2 (1) 1 (2)	1 (3)
$C_{2h}^i$ .....	....	4 (0); 2 (1)	1 (3)	....
$C_{2h}^i$ .....	....	4 (0)	1 (3)	....
$C_{2h}^i$ .....	....	....	4 (0); 1 (1)	1 (3)

TABLE 5.—ORTHORHOMBIC SYSTEM.

Space-Group.	Number of equivalent positions.					
	1	2	4	8	16	32
<i>A. Hemimorphic Hemihedry:</i>						
C <sub>1</sub> .....	4 (1)		1 (3)			.....
C <sub>2</sub> .....		4 (2)	1 (3)			.....
C <sub>3</sub> .....		2 (2)	1 (3)			.....
C <sub>4</sub> .....		4 (1)	1 (3)			.....
C <sub>5</sub> .....		2 (1); 1 (2)	1 (3)			.....
C <sub>6</sub> .....		.....	1 (3)			.....
C <sub>7</sub> .....		2 (1)	1 (3)			.....
C <sub>8</sub> .....		1 (2)	1 (3)			.....
C <sub>9</sub> .....		2 (1)	1 (3)			.....
C <sub>10</sub> .....		.....	1 (3)			.....
C <sub>11</sub> .....		2 (1)	1 (3)			.....
C <sub>12</sub> .....		.....	1 (3)			.....
C <sub>13</sub> .....		.....	1 (1); 2 (2)	1 (3)		.....
C <sub>14</sub> .....		.....	1 (2)	1 (3)		.....
C <sub>15</sub> .....		.....	3 (1)	1 (3)		.....
C <sub>16</sub> .....		2 (1)	3 (2)	1 (3)		.....
C <sub>17</sub> .....		.....	2 (1); 1 (2)	1 (3)		.....
C <sub>18</sub> .....		.....	1 (1); 1 (2)	1 (3)		.....
C <sub>19</sub> .....		.....	1 (1)	1 (3)		.....
C <sub>20</sub> .....		.....	1 (1)	1 (3); 2 (2)	1 (3)	.....
C <sub>21</sub> .....		.....	.....	1 (1)	1 (3)	.....
C <sub>22</sub> .....		2 (1)	2 (2)	1 (3)		.....
C <sub>23</sub> .....		.....	2 (1)	1 (3)		.....
C <sub>24</sub> .....		.....	1 (1); 1 (2)	1 (3)		.....



## TABLES.

The following tables provide a summary of the number and kinds of the different arrangements to be obtained from each of the space-groups. In these tabulations the symbol 1 (0), for instance, signifies one arrangement (a special case) having no variable parameters; similarly the symbol 3 (2) would mean three arrangements having two variable parameters each.

TABLE 3.—TRICLINIC SYSTEM.

Space-Group.	Number of equivalent positions.	
	1	2
<i>A. Hemihedry:</i>		
$C_1$ .....	1 (3)	....
<i>B. Holohedry:</i>		
$C_1^1$ .....	8 (0)	1 (3)

TABLE 4.—MONOCLINIC SYSTEM.

Space-Group.	Number of equivalent positions.			
	1	2	4	8
<i>A. Hemihedry:</i>				
$C_2^1$ .....	2 (2)	1 (3)	....	....
$C_2^2$ .....	....	1 (3)	....	....
$C_2^3$ .....	....	1 (2)	1 (3)	....
$C_2^4$ .....	....	....	1 (3)	....
<i>B. Hemimorphic hemihedry:</i>				
$C_2^1$ .....	4 (1)	1 (3)	....	....
$C_2^2$ .....	....	1 (3)	....	....
$C_2^3$ .....	....	2 (1)	1 (3)	....
<i>C. Holohedry:</i>				
$C_{2h}^1$ .....	8 (0)	4 (1); 2 (2)	1 (3)	....
$C_{2h}^2$ .....	....	4 (0); 1 (2)	1 (3)	....
$C_{2h}^3$ .....	....	4 (0)	2 (0) 2 (1) 1 (2)	1 (3)
$C_{2h}^4$ .....	....	4 (0); 2 (1)	1 (3)	....
$C_{2h}^5$ .....	....	4 (0)	1 (3)	....
$C_{2h}^6$ .....	....	....	4 (0); 1 (1)	1 (3)

TABLE 5.—ORTHORHOMBIC SYSTEM.

Space-Group.	Number of equivalent positions.					
	1	2	4	8	16	32
<i>A. Hemimorphic Hemihedry:</i>						
C <sub>1</sub> .....	4 (1)		1 (3)			.....
C <sub>2</sub> .....		4 (2)	1 (3)			.....
C <sub>3</sub> .....		2 (2)	1 (3)			.....
C <sub>4</sub> .....		4 (1)	1 (3)			.....
C <sub>4</sub> <sup>v</sup> .....		2 (1); 1 (2)	1 (3)			.....
C <sub>6</sub> .....		.....	1 (3)			.....
C <sub>6</sub> <sup>v</sup> .....		2 (1)	1 (3)			.....
C <sub>7</sub> .....		1 (2)	1 (3)			.....
C <sub>8</sub> .....		2 (1)	1 (3)			.....
C <sub>9</sub> .....		.....	1 (3)			.....
C <sub>10</sub> .....		2 (1)	1 (3)			.....
C <sub>11</sub> .....		2 (1)	1 (3)			.....
C <sub>12</sub> .....		.....	1 (1); 2 (2)	1 (3)		.....
C <sub>13</sub> .....		.....	1 (2)	1 (3)		.....
C <sub>14</sub> .....		.....	3 (1)	1 (3)		.....
C <sub>15</sub> .....		2 (1)	3 (2)	1 (3)		.....
C <sub>16</sub> .....		.....	2 (1); 1 (2)	1 (3)		.....
C <sub>17</sub> .....		.....	1 (1); 1 (2)	1 (3)		.....
C <sub>18</sub> .....		.....	1 (1)	1 (3)		.....
C <sub>19</sub> .....		.....	1 (1)	1 (1); 2 (2)	1 (3)	.....
C <sub>20</sub> .....		.....	.....	1 (1)	1 (3)	.....
C <sub>21</sub> .....		2 (1)	2 (2)	1 (3)		.....
C <sub>22</sub> .....		.....	2 (1)	1 (3)		.....
C <sub>23</sub> .....		.....	1 (1); 1 (2)	1 (3)		.....

TABLE 5.—ORTHORHOMBIC SYSTEM (CONTINUED).

Space-Group.	Number of equivalent positions.					
	1	2	4	8	16	32
<i>B. Enantiomorphic Hemihedry:</i>						
V <sup>1</sup> .....	8 (0)	12 (1)	1 (3)	.....	.....	.....
V <sup>2</sup> .....	.....	4 (1)	1 (3)	.....	.....	.....
V <sup>3</sup> .....	.....	2 (1)	1 (3)	.....	.....	.....
V <sup>4</sup> .....	.....	.....	1 (3)	.....	.....	.....
V <sup>5</sup> .....	.....	.....	2 (1)	1 (3)	.....	.....
V <sup>6</sup> .....	.....	4 (0)	7 (1)	1 (3)	.....	.....
V <sup>7</sup> .....	.....	.....	4 (0)	6 (1)	1 (3)	.....
V <sup>8</sup> .....	.....	4 (0)	6 (1)	1 (3)	1 (3)	.....
V <sup>9</sup> .....	.....	.....	3 (1)	1 (3)	.....	.....
<i>C. Holohedry:</i>						
V <sub>k</sub> <sup>1</sup> .....	8 (0)	12 (1)	6 (2)	1 (3)	.....	.....
V <sub>k</sub> <sup>2</sup> .....	.....	4 (0)	2 (0); 6 (1)	1 (3)	.....	.....
V <sub>k</sub> <sup>3</sup> .....	.....	8 (0)	8 (1); 1 (2)	1 (3)	.....	.....
V <sub>k</sub> <sup>4</sup> .....	.....	4 (0)	2 (0); 6 (1)	1 (3)	.....	.....
V <sub>k</sub> <sup>5</sup> .....	.....	4 (0); 2 (1)	2 (1); 3 (2)	1 (3)	.....	.....
V <sub>k</sub> <sup>6</sup> .....	.....	.....	2 (0); 2 (1)	1 (3)	.....	.....
V <sub>k</sub> <sup>7</sup> .....	.....	4 (0)	3 (1); 1 (2)	1 (3)	.....	.....
V <sub>k</sub> <sup>8</sup> .....	.....	.....	2 (0); 3 (1)	1 (3)	.....	.....
V <sub>k</sub> <sup>9</sup> .....	.....	4 (0)	2 (1); 2 (2)	1 (3)	.....	.....
V <sub>k</sub> <sup>10</sup> .....	.....	.....	2 (0); 2 (1)	1 (3)	.....	.....
V <sub>k</sub> <sup>11</sup> .....	.....	.....	2 (0)	1 (3)	.....	.....
V <sub>k</sub> <sup>12</sup> .....	.....	.....	1 (1)	.....	.....	.....
V <sub>k</sub> <sup>13</sup> .....	.....	.....	1 (2)	.....	.....	.....
V <sub>k</sub> <sup>14</sup> .....	.....	4 (0)	2 (1); 1 (2)	1 (3)	.....	.....
V <sub>k</sub> <sup>15</sup> .....	.....	2 (1)	2 (0); 2 (2)	1 (3)	.....	.....
V <sub>k</sub> <sup>16</sup> .....	.....	.....	2 (0); 1 (1)	1 (3)	.....	.....
V <sub>k</sub> <sup>17</sup> .....	.....	.....	2 (0)	1 (3)	.....	.....

TABLE 5.—ORTHORHOMBIC SYSTEM (CONTINUED).

Space-Group.	Number of equivalent positions.					
	1	2	4	8	16	32
$V_k^{16}$ .....	....	....	2 (0); 1 (2)	1 (3)	....	....
$V_k^{17}$ .....	....	....	2 (0); 1 (1)	1 (0) 1 (1) 2 (2)	1 (3)	....
$V_k^{18}$ .....	....	....	2 (0)	1 (0) 2 (1) 1 (2)	1 (3)	....
$V_k^{19}$ .....	....	4 (0)	2 (0); 6 (1)	1 (1); 4 (2)	1 (3)	....
$V_k^{20}$ .....	....	....	6 (0)	5 (1); 1 (2)	1 (3)	....
$V_k^{21}$ .....	....	....	6 (0); 1 (1)	5 (1); 2 (2)	1 (3)	....
$V_k^{22}$ .....	....	....	2 (0)	2 (0); 4 (1)	1 (3)	....
$V_k^{23}$ .....	....	....	2 (0)	4 (0); 3 (1)	3 (1); 3 (2)	1 (3)
$V_k^{24}$ .....	....	....	....	2 (0)	2 (0); 3 (1)	1 (3)
$V_k^{25}$ .....	....	4 (0)	6 (1)	1 (0); 3 (2)	1 (3)	....
$V_k^{26}$ .....	....	....	4 (0)	1 (0) 4 (1) 1 (2)	1 (3)	....
$V_k^{27}$ .....	....	....	....	2 (0); 3 (1)	1 (3)	....
$V_k^{28}$ .....	....	....	4 (0); 1 (1)	2 (1); 2 (2)	1 (3)	....

TABLE 6.—TETRAGONAL SYSTEM.

Space-Group.	Number of equivalent positions.					
	1	2	4	8	16	32
<i>A. Tetartohedry of the second Sort:</i>						
$S_4^1$ .....	4 (0)	3 (1)	1 (3)	.....	.....	.....
$S_4^2$ .....	.....	4 (0)	2 (1)	1 (3)	.....	.....
<i>B. Hemihedry of the second Sort:</i>						
$V_d^1$ .....	4 (0)	2 (0); 2 (1)	5 (1); 1 (2)	1 (3)	.....	.....
$V_d^2$ .....	.....	6 (0)	7 (1)	1 (3)	.....	.....
$V_d^3$ .....	.....	2 (0); 1 (1)	1 (1); 1 (2)	1 (3)	.....	.....
$V_d^4$ .....	.....	2 (0)	2 (1)	1 (3)	.....	.....
$V_d^5$ .....	.....	4 (0)	3 (1)	2 (1); 2 (2)	1 (3)	.....
$V_d^6$ .....	.....	.....	4 (0)	5 (1)	1 (3)	.....
$V_d^7$ .....	.....	.....	4 (0)	4 (1)	1 (3)	.....
$V_d^8$ .....	.....	.....	4 (0)	4 (1)	1 (3)	.....
$V_d^9$ .....	.....	.....	4 (0)	2 (1)	2 (1); 1 (2)	1 (3)
$V_d^{10}$ .....	.....	.....	.....	4 (0)	4 (1)	1 (3)
$V_d^{11}$ .....	.....	2 (0)	2 (0); 1 (1)	3 (1); 1 (2)	1 (3)	.....
$V_d^{12}$ .....	.....	.....	2 (0)	2 (1)	1 (3)	.....
<i>C. Tetartohedry:</i>						
$C_4^1$ .....	2 (1)	1 (1)	1 (3)	.....	.....	.....
$C_4^2$ .....	.....	.....	1 (3)	.....	.....	.....
$C_4^3$ .....	.....	3 (1)	1 (3)	.....	.....	.....
$C_4^4$ .....	.....	.....	1 (3)	.....	.....	.....
$C_4^5$ .....	.....	1 (1)	1 (1)	1 (3)	.....	.....
$C_4^6$ .....	.....	.....	1 (1)	1 (3)	.....	.....
<i>D. Paramorphic hemihedry:</i>						
$C_{4h}^1$ .....	4 (0)	2 (0); 2 (1)	1 (1); 2 (2)	1 (3)	.....	.....
$C_{4h}^2$ .....	.....	6 (0)	3 (1); 1 (2)	1 (3)	.....	.....
$C_{4h}^3$ .....	.....	2 (0); 1 (1)	2 (0); 1 (1)	1 (3)	.....	.....
$C_{4h}^4$ .....	.....	2 (0)	2 (0); 2 (1)	1 (3)	.....	.....
$C_{4h}^5$ .....	.....	2 (0)	2 (0); 1 (1)	$\begin{cases} 1 (0) \\ 1 (1) \\ 1 (2) \end{cases}$	1 (3)	.....
$C_{4h}^6$ .....	.....	.....	2 (0)	2 (0); 1 (1)	1 (3)	.....

TABLE 6.—TETRAGONAL SYSTEM (CONTINUED).

Space-Group.	Number of equivalent positions.					
	1	2	4	8	16	32
<i>E. Hemimorphic hemihedry:</i>						
$C_{4v}^1$	2 (1)	1 (1)	3 (2)	1 (3)	.....	.....
$C_{4v}^2$	.....	2 (1)	1 (2)	1 (3)	.....	.....
$C_{4v}^3$	.....	2 (1)	1 (1); 1 (2)	1 (3)	.....	.....
$C_{4v}^4$	.....	1 (1)	1 (1); 1 (2)	1 (3)	.....	.....
$C_{4v}^5$	.....	2 (1)	1 (1)	1 (3)	.....	.....
$C_{4v}^6$	.....	1 (1)	1 (1)	1 (3)	.....	.....
$C_{4v}^7$	.....	3 (1)	2 (2)	1 (3)	.....	.....
$C_{4v}^8$	.....	.....	2 (1)	1 (3)	.....	.....
$C_{4v}^9$	.....	1 (1)	1 (1)	2 (2)	1 (3)	.....
$C_{4v}^{10}$	.....	.....	2 (1)	1 (2)	1 (3)	.....
$C_{4v}^{11}$	.....	.....	1 (1)	1 (2)	1 (3)	.....
$C_{4v}^{12}$	.....	.....	.....	1 (1)	1 (3)	.....
<i>F. Enantiomorphic hemihedry:</i>						
$D_4^1$	4 (0)	2 (0); 2 (1)	7 (1)	1 (3)	.....	.....
$D_4^2$	.....	2 (0); 1 (1)	3 (1)	1 (3)	.....	.....
$D_4^3$	.....	.....	3 (1)	1 (3)	.....	.....
$D_4^4$	.....	.....	1 (1)	1 (3)	.....	.....
$D_4^5$	.....	6 (0)	9 (1)	1 (3)	.....	.....
$D_4^6$	.....	2 (0)	4 (1)	1 (3)	.....	.....
$D_4^7$	.....	.....	3 (1)	1 (3)	.....	.....
$D_4^8$	.....	.....	1 (1)	1 (3)	.....	.....
$D_4^9$	.....	2 (0)	2 (0); 1 (1)	5 (1)	1 (3)	.....
$D_4^{10}$	.....	.....	2 (0)	4 (1)	1 (3)	.....
<i>G. Holohedry:</i>						
$D_{4h}^1$	4 (0)	2 (0); 2 (1)	7 (1)	5 (2)	1 (3)	.....
$D_{4h}^2$	.....	4 (0)	2 (0); 2 (1)	4 (1); 1 (2)	1 (3)	.....
$D_{4h}^3$	.....	4 (0)	2 (0); 2 (1)	4 (1); 1 (2)	1 (3)	.....
$D_{4h}^4$	.....	2 (0)	2 (0); 1 (1)	1 (0); 4 (1)	1 (3)	.....
$D_{4h}^5$	.....	4 (0)	4 (1)	3 (2)	1 (3)	.....
$D_{4h}^6$	.....	2 (0)	2 (0); 1 (1)	2 (1); 1 (2)	1 (3)	.....
$D_{4h}^7$	.....	2 (0); 1 (1)	2 (0); 1 (1)	2 (1); 2 (2)	1 (3)	.....
$D_{4h}^8$	.....	.....	2 (0); 1 (1)	1 (0); 2 (1)	1 (3)	.....
$D_{4h}^9$	.....	6 (0)	7 (1)	1 (1); 3 (2)	1 (3)	.....
$D_{4h}^{10}$	.....	4 (0)	2 (0); 4 (1)	3 (1); 2 (2)	1 (3)	.....
$D_{4h}^{11}$	.....	.....	4 (0)	1 (0); 5 (1)	1 (3)	.....
$D_{4h}^{12}$	.....	2 (0)	4 (0); 1 (1)	5 (1); 1 (2)	1 (3)	.....
$D_{4h}^{13}$	.....	.....	4 (0)	3 (1); 1 (2)	1 (3)	.....
$D_{4h}^{14}$	.....	2 (0)	2 (0); 3 (1)	1 (1); 2 (2)	1 (3)	.....
$D_{4h}^{15}$	.....	2 (0)	2 (1)	1 (0); 1 (1); 1 (2)	1 (3)	.....
$D_{4h}^{16}$	.....	.....	4 (0); 1 (1)	3 (1); 1 (2)	1 (3)	.....
$D_{4h}^{17}$	.....	2 (0)	2 (0); 1 (1)	1 (0); 4 (1)	1 (1); 3 (2)	1 (3)
$D_{4h}^{18}$	.....	.....	4 (0)	1 (0); 3 (1)	2 (1); 2 (2)	1 (3)
$D_{4h}^{19}$	.....	.....	2 (0)	2 (0); 1 (1)	2 (1); 1 (2)	1 (3)
$D_{4h}^{20}$	.....	.....	.....	2 (0)	1 (0); 3 (1)	1 (3)

TABLE 7.—CUBIC SYSTEM.

Space-Group.	Number of equivalent positions.													
	1	2	3	4	6	8	12	16	24	32	48	64	96	192
<b>A. Tetartohedry:</b>														
T <sub>1</sub>	2 (0)	2 (0)	1 (1)	4 (1)	1 (3)	1 (1)	1 (3)	1 (1)	2 (1)	1 (3)	1 (3)	1 (3)	1 (3)	1 (3)
T <sub>2</sub>	1 (0)	1 (0)	1 (0)	1 (1)	2 (1)	1 (1)	2 (1)	1 (3)	1 (3)	1 (3)	1 (3)	1 (3)	1 (3)	1 (3)
T <sub>3</sub>	1 (0)	1 (0)	1 (1)	1 (1)	1 (3)	1 (1)	1 (3)	1 (3)	1 (3)	1 (3)	1 (3)	1 (3)	1 (3)	1 (3)
T <sub>4</sub>	1 (0)	1 (0)	1 (1)	1 (1)	1 (3)	1 (1)	1 (3)	1 (3)	1 (3)	1 (3)	1 (3)	1 (3)	1 (3)	1 (3)
T <sub>5</sub>	1 (0)	1 (0)	1 (1)	1 (1)	1 (3)	1 (1)	1 (3)	1 (3)	1 (3)	1 (3)	1 (3)	1 (3)	1 (3)	1 (3)
<b>B. Paramorphic hemihedry:</b>														
T <sub>1</sub>	2 (0)	2 (0)	2 (0)	2 (0)	4 (1)	1 (1)	2 (2)	1 (3)	1 (3)	1 (3)	1 (3)	1 (3)	1 (3)	1 (3)
T <sub>2</sub>	1 (0)	1 (0)	2 (0)	1 (0)	1 (1)	1 (1)	2 (1)	1 (3)	1 (3)	1 (3)	1 (3)	1 (3)	1 (3)	1 (3)
T <sub>3</sub>	1 (0)	1 (0)	2 (0)	2 (0)	1 (0)	1 (0)	1 (0)	1 (0)	1 (0); 1 (1)	1 (1)	1 (1); 1 (2)	1 (3)	1 (3)	1 (3)
T <sub>4</sub>	1 (0)	1 (0)	2 (0)	1 (0)	1 (0)	2 (0)	2 (1)	2 (0)	1 (2)	1 (1)	1 (1)	1 (3)	1 (3)	1 (3)
T <sub>5</sub>	1 (0)	1 (0)	2 (0)	1 (0)	1 (1)	1 (1)	2 (1)	1 (1)	1 (2)	1 (1)	1 (3)	1 (3)	1 (3)	1 (3)
T <sub>6</sub>	1 (0)	1 (0)	2 (0)	2 (0)	1 (1)	1 (1)	2 (1)	1 (1)	1 (3)	1 (1)	1 (3)	1 (3)	1 (3)	1 (3)
T <sub>7</sub>	1 (0)	1 (0)	2 (0)	2 (0)	1 (1)	2 (0)	2 (1)	1 (1)	1 (1)	1 (1)	1 (3)	1 (3)	1 (3)	1 (3)
T <sub>8</sub>	1 (0)	1 (0)	2 (0)	2 (0)	1 (1)	2 (0)	2 (1)	1 (1)	1 (1)	1 (1)	1 (3)	1 (3)	1 (3)	1 (3)
<b>C. Hemimorphic hemihedry:</b>														
T <sub>1</sub>	2 (0)	2 (0)	2 (0)	1 (1)	2 (1)	1 (1)	1 (1); 1 (2)	1 (1)	1 (3)	1 (3)	1 (2)	1 (3)	1 (3)	1 (3)
T <sub>2</sub>	1 (0)	1 (0)	4 (0)	4 (0)	1 (0)	1 (1)	1 (0); 1 (1)	1 (1)	2 (1)	1 (3)	1 (2)	1 (3)	1 (3)	1 (3)
T <sub>3</sub>	1 (0)	1 (0)	1 (0)	1 (1)	1 (1)	1 (1)	1 (0); 1 (1)	1 (1)	1 (1); 1 (2)	1 (3)	1 (3)	1 (3)	1 (3)	1 (3)
T <sub>4</sub>	1 (0)	1 (0)	3 (0)	3 (0)	1 (1)	1 (1)	3 (1)	1 (1)	1 (3)	1 (1)	2 (1)	1 (3)	1 (3)	1 (3)
T <sub>5</sub>	1 (0)	1 (0)	2 (0)	2 (0)	2 (0)	2 (0)	2 (0)	1 (1)	2 (0)	1 (1)	1 (3)	1 (3)	1 (3)	1 (3)
T <sub>6</sub>	1 (0)	1 (0)	2 (0)	2 (0)	2 (0)	2 (0)	2 (0)	1 (1)	1 (1)	1 (1)	1 (3)	1 (3)	1 (3)	1 (3)

TABLE 7.—CUBIC SYSTEM (CONTINUED).

Space-Group.	Number of equivalent positions.													
	1	2	3	4	6	8	12	16	24	32	48	64	96	192
<i>D. Enantiomorphic hemihedry:</i>														
$O_1^1$	2 (0)	2 (0)	2 (0)	4 (1)	1 (1)	2 (1)	1 (3)	1 (3)	1 (3)	1 (1)	3 (1)	1 (1)	1 (3)	1 (3)
$O_2^1$	1 (0)	2 (0)	2 (0)	3 (0)	1 (1)	5 (1)	1 (3)	1 (3)	1 (0); 1 (1)	1 (1)	3 (1)	1 (1)	1 (3)	1 (3)
$O_3^1$	1 (0)	2 (0)	2 (0)	2 (0)	2 (0)	2 (0)	2 (0)	2 (0)	2 (0)	1 (1)	2 (1)	1 (3)	1 (3)	1 (3)
$O_4^1$	1 (0)	2 (0)	2 (0)	1 (0)	1 (0)	1 (0); 2 (1)	2 (1)	1 (1)	2 (1)	1 (1)	1 (3)	1 (3)	1 (3)	1 (3)
$O_5^1$	1 (0)	2 (0)	2 (0)	1 (1)	1 (1)	1 (1)	1 (3)	1 (3)	1 (3)	1 (1)	1 (3)	1 (3)	1 (3)	1 (3)
$O_6^1$	1 (0)	2 (0)	2 (0)	1 (1)	1 (1)	1 (1)	1 (3)	1 (3)	1 (3)	1 (1)	1 (3)	1 (3)	1 (3)	1 (3)
$O_7^1$	1 (0)	2 (0)	2 (0)	1 (1)	1 (1)	1 (1)	1 (3)	1 (3)	1 (3)	1 (1)	1 (3)	1 (3)	1 (3)	1 (3)
$O_8^1$	1 (0)	2 (0)	2 (0)	1 (1)	1 (1)	1 (1)	1 (3)	1 (3)	1 (3)	1 (1)	1 (3)	1 (3)	1 (3)	1 (3)
<i>E. Holohedry:</i>														
$O_1^2$	2 (0)	2 (0)	2 (0)	2 (1)	1 (1)	3 (1)	3 (2)	3 (2)	3 (2)	1 (1)	1 (3)	1 (3)	1 (3)	1 (3)
$O_2^2$	1 (0)	1 (0)	1 (0)	1 (0)	1 (0)	1 (1)	2 (1)	2 (1)	2 (1)	1 (1)	1 (3)	1 (3)	1 (3)	1 (3)
$O_3^2$	1 (0)	1 (0)	1 (0)	3 (0)	1 (0)	3 (1)	1 (1); 1 (2)	1 (1)	1 (1); 1 (2)	1 (1)	1 (3)	1 (3)	1 (3)	1 (3)
$O_4^2$	1 (0)	1 (0)	1 (0)	1 (0)	1 (1)	1 (1)	2 (1); 1 (2)	2 (1); 1 (2)	2 (1); 1 (2)	1 (1)	1 (3)	1 (3)	1 (3)	1 (3)
$O_5^2$	1 (0)	2 (0)	2 (0)	2 (0)	1 (0)	1 (0)	1 (0); 1 (1)	1 (0); 1 (1)	1 (0); 1 (1)	1 (1)	3 (1)	1 (1)	2 (2)	1 (3)
$O_6^2$	1 (0)	2 (0)	2 (0)	2 (0)	2 (0)	2 (0)	2 (0)	2 (0)	2 (0)	1 (1)	2 (1)	1 (1)	1 (1); 1 (2)	1 (3)
$O_7^2$	1 (0)	2 (0)	2 (0)	2 (0)	2 (0)	2 (0)	2 (0)	2 (0)	2 (0)	1 (1)	1 (1)	1 (1)	1 (1); 1 (2)	1 (3)
$O_8^2$	1 (0)	2 (0)	2 (0)	1 (0)	1 (0)	1 (0)	1 (0)	1 (0)	1 (0)	2 (0)	1 (0)	1 (1)	2 (1)	1 (3)
$O_9^2$	1 (0)	2 (0)	2 (0)	1 (0)	1 (0)	1 (0); 1 (1)	2 (1)	2 (1)	2 (1)	1 (1)	1 (1); 2 (2)	1 (1)	1 (3)	1 (3)
$O_{10}^2$	1 (0)	2 (0)	2 (0)	1 (0)	1 (0)	1 (0)	2 (0)	2 (0)	2 (0)	1 (1)	2 (1)	1 (1)	1 (3)	1 (3)



TABLE 8.—HEXAGONAL SYSTEM.

## I. RHOMBOHEDRAL DIVISION

Space-Group.	Number of equivalent positions.					
	1	2	3	4	6	12
<b>A. Tetartohedry:</b>						
177 $C_3^1$ .....	3 (1)	.....	1 (3)	.....	.....	.....
$C_3^2$ .....	.....	.....	1 (3)	.....	.....	.....
$C_3^3$ .....	.....	.....	1 (3)	.....	.....	.....
$C_2^4$ .....	1 (1)	.....	1 (3)	.....	.....	.....
<b>B. Paramorphic hemihedry:</b>						
$C_{3i}^1$ .....	2 (0)	2 (1)	2 (0)	.....	1 (3)	.....
$C_{3i}^2$ .....	2 (0)	1 (1)	2 (0)	.....	1 (3)	.....
<b>C. Hemimorphic hemihedry:</b>						
$C_{3v}^1$ .....	3 (1)	.....	1 (2)	.....	1 (3)	.....
$C_{3v}^2$ .....	1 (1)	1 (1)	1 (2)	.....	1 (3)	.....
$C_{3v}^3$ .....	.....	3 (1)	.....	.....	1 (3)	.....
$C_{3v}^4$ .....	.....	2 (1)	.....	.....	1 (3)	.....
$C_{3v}^5$ .....	1 (1)	.....	1 (2)	.....	1 (3)	.....
$C_{3v}^6$ .....	.....	1 (1)	.....	.....	1 (3)	.....
<b>D. Enantiomorphic hemihedry:</b>						
$D_3^1$ .....	6 (0)	3 (1)	2 (1)	.....	1 (3)	.....
$D_3^2$ .....	2 (0)	2 (1)	2 (1)	.....	1 (3)	.....
$D_3^3$ .....	.....	.....	2 (1)	.....	1 (3)	.....
$D_3^4$ .....	.....	.....	2 (1)	.....	1 (3)	.....
$D_3^5$ .....	.....	.....	2 (1)	.....	1 (3)	.....
$D_3^6$ .....	.....	.....	2 (1)	.....	1 (3)	.....
$D_3^7$ .....	2 (0)	1 (1)	2 (1)	.....	1 (3)	.....
<b>E. Holohedry:</b>						
$D_{3d}^1$ .....	2 (0)	2 (0); 1 (1)	2 (0)	1 (1)	2 (1); 1 (2)	1 (3)
$D_{3d}^2$ .....	.....	4 (0)	.....	2 (1)	1 (0); 1 (1)	1 (3)
$D_{3d}^3$ .....	2 (0)	2 (1)	2 (0)	.....	2 (1); 1 (2)	1 (3)
$D_{3d}^4$ .....	.....	2 (0)	.....	2 (1)	1 (0); 1 (1)	1 (3)
$D_{3d}^5$ .....	2 (0)	1 (1)	2 (0)	.....	2 (1); 1 (2)	1 (3)
203 $D_{3d}^6$ .....	.....	2 (0)	.....	1 (1)	1 (0); 1 (1)	1 (3)

TABLE 9.—HEXAGONAL SYSTEM (CONTINUED).  
II. HEXAGONAL DIVISION

Space-Group.	Number of equivalent positions.							
	1	2	3	4	6	8	12	24
<i>A. Trigonal paramorphic hemihedry:</i>								
$C_{3h}$ .....	6 (0)	3 (1)	2 (2)	....	1 (3)	....	....	....
<i>B. Trigonal Holohedry:</i>								
$D_{3h}^1$ .....	6 (0)	3 (1)	2 (1)	....	3 (2)	....	1 (3)	....
$D_{3h}^2$ .....	....	6 (0)	....	3 (1)	1 (1); 1 (2)	....	1 (3)	....
$D_{3h}^3$ .....	2 (0)	2 (0); 1 (1)	2 (1)	1 (1)	3 (2)	....	1 (3)	....
$D_{3h}^4$ .....	....	4 (0)	....	2 (1)	1 (1); 1 (2)	....	1 (3)	....
<i>C. Hexagonal Tetartohedry:</i>								
$C_6$ .....	1 (1)	1 (1)	1 (1)	....	1 (3)	....	....	....
$C_3^2$ .....	....	....	....	....	1 (3)	....	....	....
$C_3$ .....	....	....	....	....	1 (3)	....	....	....
$C_2^3$ .....	....	....	2 (1)	....	1 (3)	....	....	....
$C_2^2$ .....	....	....	2 (1)	....	1 (3)	....	....	....
$C_2^1$ .....	....	2 (1)	....	....	1 (3)	....	....	....

TABLE 9.—HEXAGONAL SYSTEM (CONTINUED).  
II. HEXAGONAL DIVISION (Continued.)

Space-Group.	Number of equivalent positions.							
	1	2	3	4	6	8	12	24
<i>D. Hemimorphic hemihedry:</i>								
$C_{6h}^1$ .....	1 (1)	1 (1)	1 (1)	...	2 (2)	...	1 (3)	...
$C_{6h}^2$ .....	...	1 (1)	...	1 (1)	1 (1)	...	1 (3)	...
$C_{6h}^3$ .....	...	1 (1)	...	1 (1)	1 (2)	...	1 (3)	...
$C_{6h}^4$ .....	...	2 (1)	...	...	1 (2)	...	1 (3)	...
<i>E. Paracrystallic hemihedry:</i>								
$C_{6h}^1$ .....	2 (0)	2 (0); 1 (1)	2 (0)	1 (1)	1 (1); 2 (2)	...	1 (3)	...
$C_{6h}^2$ .....	...	4 (0)	...	2 (1)	1 (0); 1 (2)	...	1 (3)	...
<i>F. Enantiomorphic hemihedry:</i>								
$D_6^1$ .....	2 (0)	2 (0); 1 (1)	2 (0)	1 (1)	5 (1)	...	1 (3)	...
$D_6^2$ .....	...	...	...	...	2 (1)	...	1 (3)	...
$D_6^3$ .....	...	...	...	...	2 (1)	...	1 (3)	...
$D_6^4$ .....	...	...	4 (0)	...	6 (1)	...	1 (3)	...
$D_6^5$ .....	...	...	4 (0)	...	6 (1)	...	1 (3)	...
$D_6^6$ .....	...	4 (0)	...	2 (1)	2 (1)	...	1 (3)	...
<i>G. Holohedry:</i>								
$D_{6h}^1$ .....	2 (0)	2 (0); 1 (1)	2 (0)	1 (1)	5 (1)	...	4 (2)	1 (3)
$D_{6h}^2$ .....	...	2 (0)	...	2 (0); 1 (1)	2 (0)	1 (1)	3 (1); 1 (2)	1 (3)
$D_{6h}^3$ .....	...	2 (0)	...	2 (0); 1 (1)	1 (0); 1 (1)	1 (1)	1 (1); 2 (2)	1 (3)
$D_{6h}^4$ .....	...	4 (0)	...	2 (1)	1 (0); 1 (1)	...	1 (1); 2 (2)	1 (3)

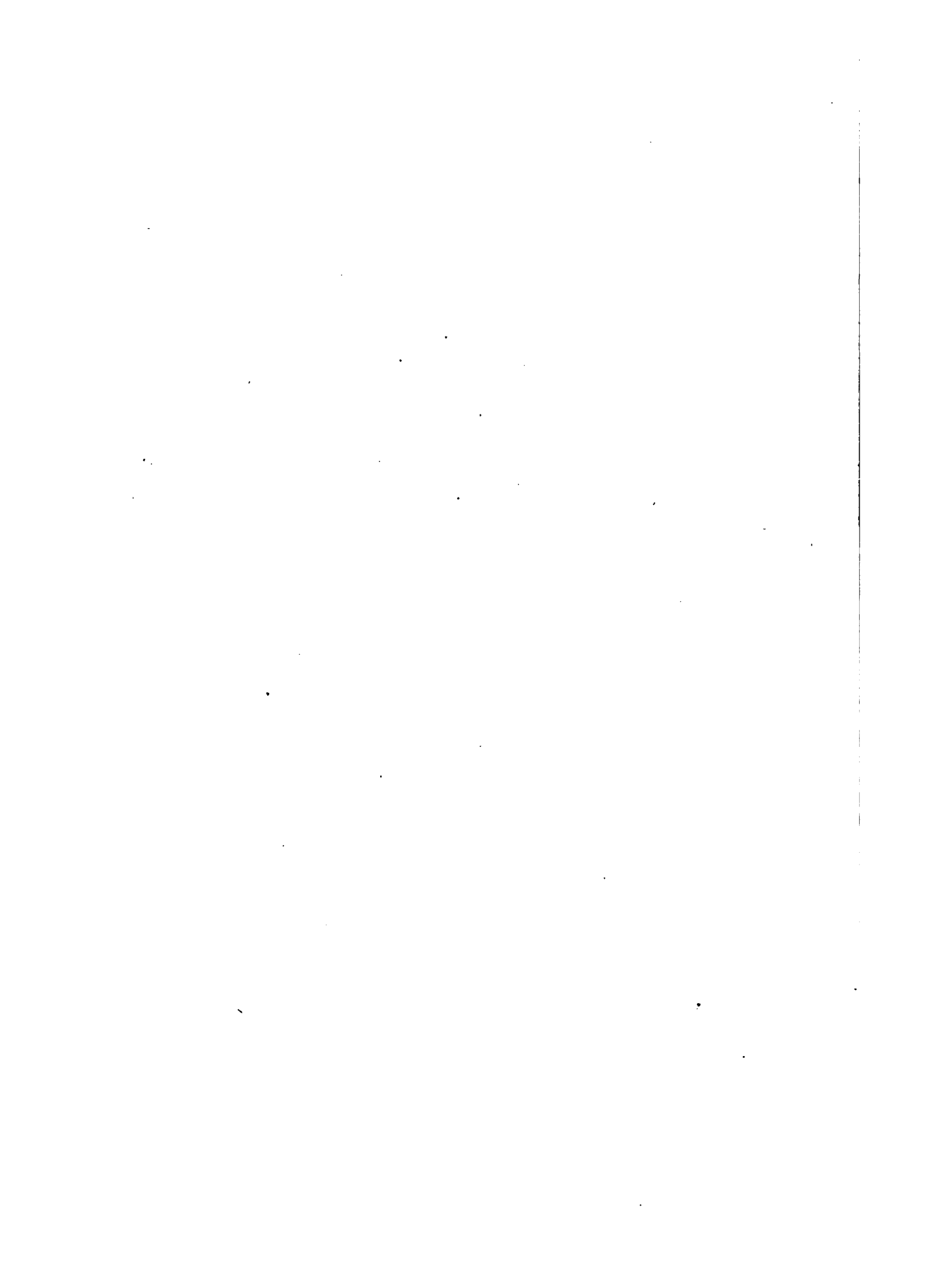









3 2044 050 756 428

This book should be returned to the Library on or before the last date stamped below.

A fine of five cents a day is incurred by retaining it beyond the specified time.

Please return promptly.

~~DEC 10 1946~~

~~DEC 10 1946~~

~~SEP 23 1948~~

~~SEP 27 1947~~

~~JUN 10 1947~~

~~DEC 27 1948~~

~~DEC 27 1948~~

~~FEB 07 1949~~

~~DEC 09 1948~~  
~~JUN 15 1948~~

~~FEB 10 1949~~  
*Mar 7, 58*  
*Renewed*

~~MAR 05 1949~~

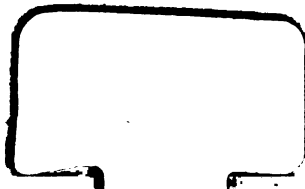



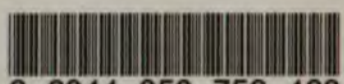

3 2044 050 756 428